



CRANMORE

INSERT

Operating & Installation Instructions

CONTENTS

QUICK GUIDE	4
OPERATING INSTRUCTIONS	5
GENERAL	5
DOOR OPERATION	5
FUEL	5
RIDDLING GRATE	6
CONTROLLING THE FIRE	6
LIGHTING	6
REFUELLING	7
ASH CLEARANCE	7
REDUCED BURNING	7
CLEANING AND MAINTENANCE	7
SERVICING	8
THROAT PLATE AND FLUEWAY CLEANING	8
TROUBLESHOOTING	9
INSTALLATION INSTRUCTIONS	10
HEALTH AND SAFETY PRECAUTIONS	10
UNPACKING THE STOVE	10
AIR SUPPLY	10
CO ALARMS	10
SPECIFICATIONS	10
CHIMNEY	11
HEARTH AND FIRE SURROUND	11
PREPARATION OF FIREPLACE	12
FITTING THE CONVECTION CASING, FLUE PIPE AND STOVE	13
PRE LIGHTING CHECK	15
COMMISSIONING	16
CAA AND SMOKE CONTROL	16
APPLIANCE LIFESPAN	16
CHIMNEY SWEEPING	16
CO ALARM	17
MARKET SURVEILLANCE	18
DIMENSIONS	19
PARTS LIST	20
CE CERTIFICATION	21

QUICK GUIDE

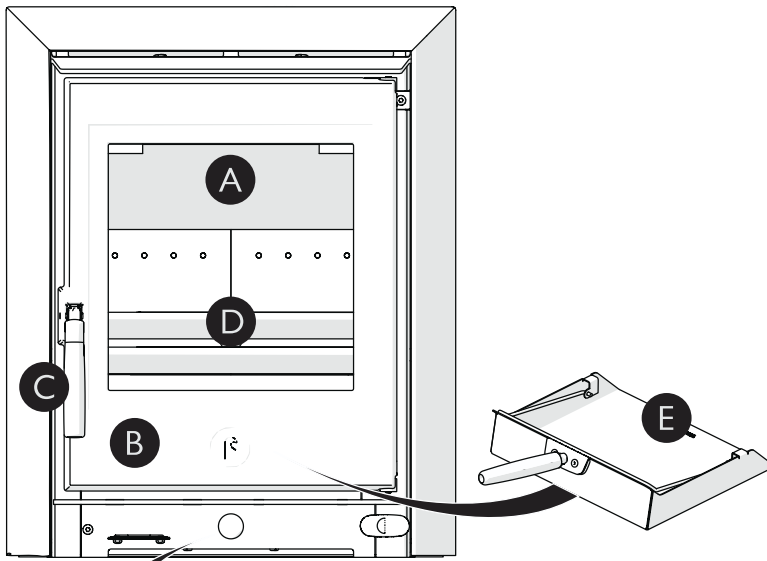

- A Throat plate**
Improves efficiency of stove by slowing down flue gases
- B Door**
Keep closed when stove is in use
- C Door handle**
lift to open
- D Fuel retainer**
Protects glass and prevents spillage
- E Ashpan**
For clean and easy ash removal

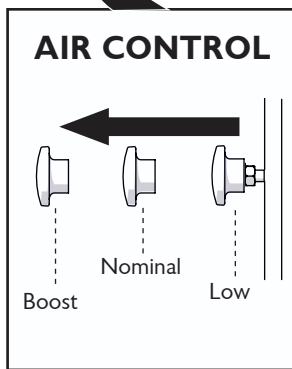

MAINTENANCE AND CLEANING

- GLASS** Wipe with damp, lint free cloth. Any stubborn deposits on the glass may be removed with a proprietary stove glass cleaner or ceramic hob cleaner.
- THROAT PLATE** Take down once a month and clean. Sweep sooty deposits into fire
- CHIMNEY** Have chimney swept twice a year. Chimney can be swept through stove.
- SERVICING** Stove should be serviced by a professional at least once a year.

LIGHTING AND CONTROLLING THE FIRE

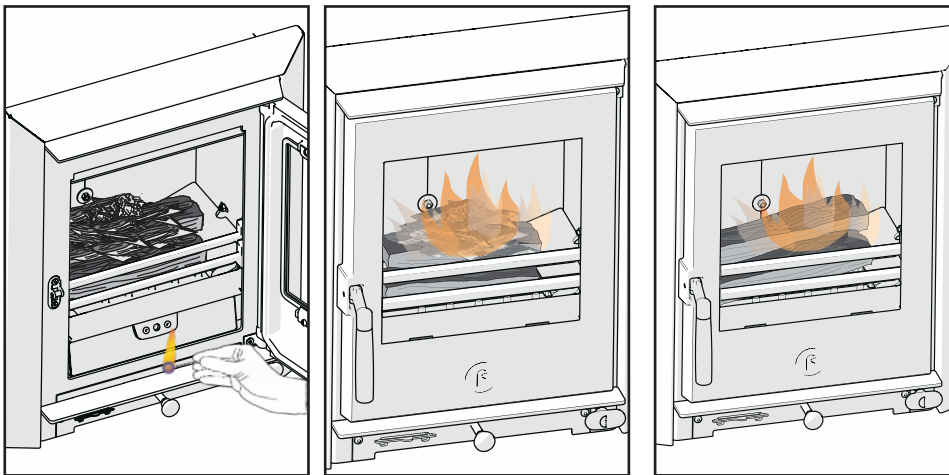

Set the air control knob to 'Boost' position. Place two dry, well seasoned logs left to right on the grate. Build a stack of 6-8 kindling sticks on top of the logs and place a firelighter amongst the sticks.

Light the firelighter and leave the door cracked open for a few minutes then shut the door. Let the fire get established with the air control still set to boost. Once established set the air control to 'Nominal' position.

After the initial fuel load has reduced to embers, place one or two logs on top leaving the door cracked open for a few minutes to get the logs alight. Set the air control to 'Nominal' position once the fire is fully established.

Suitable fuels for your Charnwood:
Wood logs

Unsuitable fuels:
Petroleum coke
Liquid fuel
Household waste
Coal singles
Small nuts or coal dust
Wet or unseasoned wood
Smokeless mineral fuel

GENERAL

Before lighting the stove, check with the installer that the work and checks described in the Installation Instructions have been carried out correctly and that the chimney has been swept, is sound and free from any obstructions. The stove is not suitable for use in a shared flue system.

All local regulations, including national and European Standards need to be complied with when installing and operating this stove.

Remember that the stove will be hot and that it is made from hard materials – ensure that you have good balance before operating it. Heat radiated from stove, especially through the glass, could set combustible objects on fire. Please see page 11 for minimum safe distances to combustibles. Do not use or store any flammable substances such as aerosols near the stove when it is alight as this could result in explosion or flash ignition.

When using the stove in situations where children, aged and/or infirm persons are present, a fireguard must be used to prevent accidental contact with the stove. The fireguard should be manufactured in accordance with BS 8423:2002.

The stove is suitable for intermittent operation.

The Clean Air Act 1993 and Smoke Control Areas:

Under the Clean Air Act local authorities may declare the whole or part of the district of the authority to be a smoke control area. It is an offence to emit smoke from a chimney of a building, from a furnace or from any fixed boiler if located in a designated smoke control area. It is also an offence to acquire an “unauthorised fuel” for use within a smoke control area unless it is used in an “exempt” appliance (“exempted” from the controls which generally apply in the smoke control area).

In England appliances are exempted by publication on a list by the Secretary of State in accordance with changes made to sections 20 and 21 of the Clean Air Act 1993 by section 15 of the Deregulation Act 2015. Similarly in Scotland appliances are exempted by publication on a list by Scottish Ministers under section 50 of the Regulatory Reform (Scotland) Act 2014.

In Wales and Northern Ireland these are authorised by regulations made by Welsh Ministers and by the Department of the Environment respectively.

Further information on the requirements of the Clean Air Act can be found here at:

<https://www.gov.uk/smoke-control-area-rules>

Your local authority is responsible for implementing the Clean Air Act 1993 including designation and supervision of smoke control areas and you can contact them for details of Clean Air Act requirements.

The Cranmore Insert has been recommended as suitable for use in smoke control areas when burning wood logs. The Cranmore Insert has been factory fitted with a permanent stop to prevent full closure of the air controls.

DOOR OPERATION

Fig. 1 Stove controls

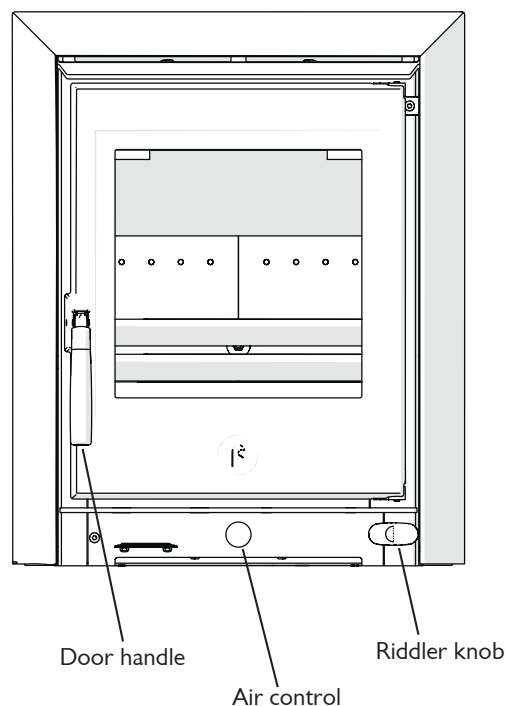

The door handle has been carefully designed so that in normal use it may be operated using bare hands. However, if you need to open the doors when the fire is running at maximum, then the use of the gloves provided may be required

FUEL

Only dry well seasoned wood logs should be burnt on this appliance as burning wet unseasoned wood will give rise to heavy tar deposits in the stove, on the glass and within the chimney. For the same reason hardwood is better than soft wood. Burning wet unseasoned wood will also result in considerably reduced outputs. The wood logs

OPERATING INSTRUCTIONS



should be cut and split and then left to season in a well ventilated dry place for at least one year but preferably two years before use and should have a moisture content of less than 20% (ideally below 17%). The maximum log size to be used is 300mm (13.7 inches) long, 75mm (3 inches) in diameter.

PETROLEUM COKE IS NOT SUITABLE FOR USE ON THIS APPLIANCE. ITS USE WILL INVALIDATE THE GUARANTEE.

Fig. 2 Riddler knob

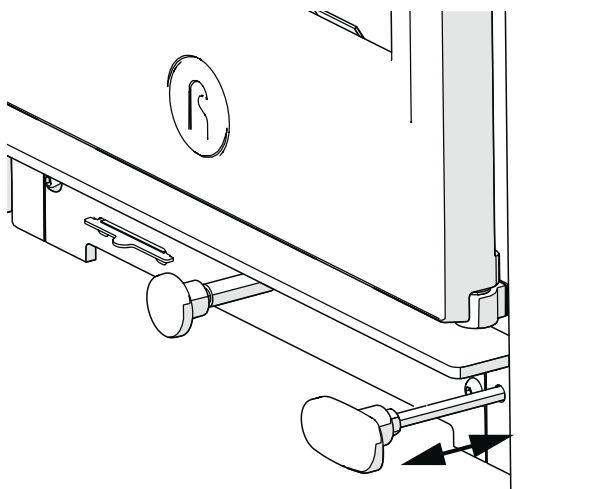

Pull handle in and out to riddle

Fig. 3 Stove controls

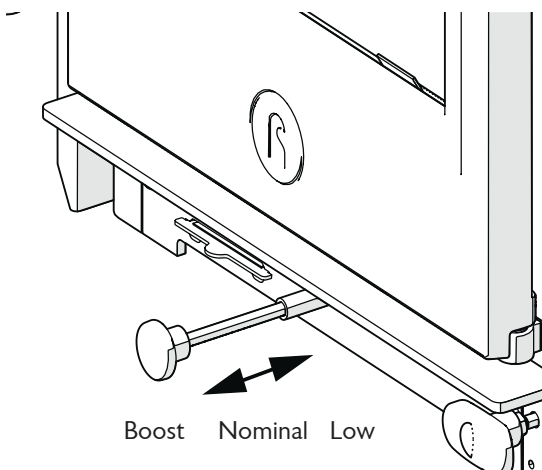

RIDDLING GRATE

Your Charnwood stove is fitted with a riddling grate to enable easy ash removal. The grate has two positions:

1) When the grate bars are in a vertical position they allow ash to fall down into the ashpan.

2) In the wood position the grate bars are horizontal. In this position ash is able to build up on the grate as is necessary for effective wood burning.

Movement of the grate from one position to the other is effected using the riddler handle, as shown in Fig. 2.

To riddle the appliance, pull the riddler handle rapidly in and out several times. When burning wood the ash should be allowed to build up a little and riddling should only be carried out once or twice a week, using the glove provided if necessary.

CONTROLLING THE FIRE

The rate of burning and hence the output is controlled by the air control (see Fig. 3).

Open the air control fully (boost position) when lighting or when rapid burning is required. It should not be left fully open for long periods as this can cause over-firing or excessive smoke production. For a higher burning rate move the air control to the 'Nominal' position or for low burning to the 'Low' position.

When the fire is burning normally the air control gives enough airwash to keep the glass clean. However, it will not always be possible to keep the glass clean with the air control fully closed.

LIGHTING

On initial lighting, the stove may smoke and give off an odour as the silicon paint with which the firebox is painted reacts to the heat. This is normal and will cease after a short time, but meanwhile the room should be kept well ventilated. At first, only light a small fire and burn it slowly for two hours to allow any residual moisture in the chimney to evaporate. The lighting process is shown in the 'Quick Guide'.

When burning wood on this stove, the 'top down' lighting method is recommended to reduce smoke and to help to heat the flue quickly.

Set the air control knob to 'Boost' position and make sure the grate is in the correct position for burning wood. Place two dry, well seasoned logs left to right on the grate. Build a stack of 6-8 kindling sticks on top of the logs and place a firelighter amongst the sticks. Light the firelighter. The door may be left cracked open for a few minutes to assist the combustion and heat up the firebox more quickly if required. Keep the air control in boost position until the fire is well

established.

After the initial fuel load has burnt down, place one or two small logs on top of the embers leaving the door cracked open for a few minutes to get the logs lit. Once long flames appear over the fire, shut the stove door and reduce the air control to the 'nominal output' setting.

Fig. 4 Ashpan

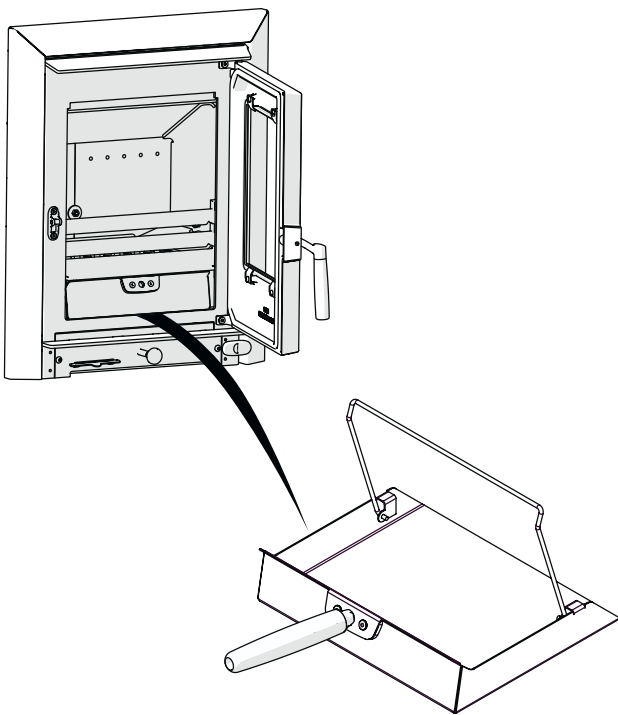

During the lighting period, do not leave the stove unattended. Do not leave the door open except as directed above to avoid excessive smoke. The appliance must not be operated with the door left open except as directed above.

A stove can reasonably be expected to make some ticking noises during heating and cooling cycles caused by metal expansion and contraction in the firebox. This is entirely normal and will not cause damage to the stove or adversely affect its performance.

REFUELLING

Keep the firebox well filled but do not allow fuel to spill over the top of the fuel retainer or be stacked higher than the combustion air holes in the rear firebricks. **The maximum amount of fuel specified in this manual should not be exceeded, overloading can cause excess smoke.**

If there is insufficient burning material in the firebed to light a new fuel charge, excessive smoke emission can occur. Refuelling must be carried out onto a sufficient quantity of glowing embers so that the new fuel charge will ignite in a reasonable period. If there are too few embers in the fire bed add suitable kindling to prevent excess smoke. Open the air control fully and crack the door open to re-establish the fire.

ASH CLEARANCE

The ashpan should be emptied regularly before it becomes too full. Never allow the ash to accumulate in the ashpan so that it comes in contact with the underside of the grate as this will seriously damage the grate bars. The ashpan can be removed with the tool provided and held steady with the attached handle. Gloves are recommended when removing the ashpan. Care should be taken to ensure that ash is cool before emptying it into plastic liners or bins. To make ash removal easier there is a special Charnwood ash carrier available. This may be purchased from your supplier or, in case of difficulty, directly from Charnwood. **Ash should not be stored inside.**

REDUCED BURNING

For reduced burning the fire door must be closed.

When burning wood in areas that are not smoke controlled, load some large logs on the fire and allow to burn for half an hour before closing the air control down as much as possible whilst still maintaining flames on the logs. Some experimentation may be necessary to find the setting most suitable for the type of fuel being used and the draw on the chimney.

To revive the fire, riddle the fire, and open the air control to maximum. When the fire is burning well load on more fuel as necessary and adjust the air control to the desired setting.

CLEANING AND MAINTENANCE

CLEANING

The stove is finished with a high temperature paint which will withstand the temperatures encountered in normal use. This may be cleaned with a damp lint-free cloth when the stove is cold. Should re-painting become necessary, high temperature paints are available from your supplier or from stove shops.

CLEANING THE GLASS

Most deposits on the glass may be burnt off simply by running the fire

at a fast rate for a few minutes. If it becomes necessary to clean the glass then open the door and allow it to cool. Clean the glass using a damp cloth and then wiping over with a dry cloth. Any stubborn deposits on the glass may be removed with a proprietary stove glass cleaner or ceramic hob cleaner. Do not use abrasive cleaners or pads as these can scratch the surface which will weaken the glass and cause premature failure.

Fig. 5 Throat plate

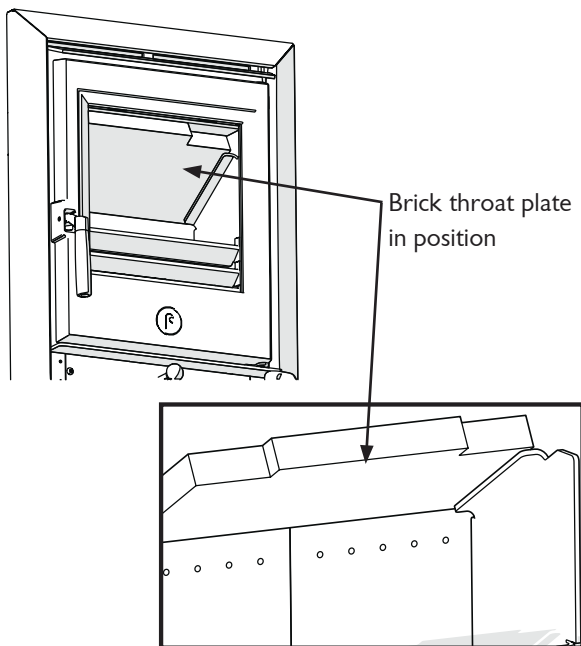

WHEN NOT IN USE

If the fire is going to be out of use for a long period (for instance in the summer) then to prevent condensation, and hence corrosion, the air control should be left fully open and the fire door left ajar. It is also advisable to sweep the chimney and clean out the fire. Spraying the inside of the door and firebox with a light oil, such as WD40, will also help to keep all internal parts working well. After long periods where the fire has been out of use, the chimney and appliance flueways should be cleaned before lighting.

DOOR SEALS

For the fire to operate correctly it is important that the door seals are in good condition. Check that they do not become worn or frayed and replace them when necessary.

SERVICING

It is recommended that the fire is serviced once a year to keep it in first class working order. After cleaning out the firebox thoroughly, check that all internal parts are in good working order, replacing any parts that are beginning to show signs of wear. Check that the door seal is in good condition and that the door seals correctly. Repairs or modifications may only be carried out by the Manufacturer or their approved agents. Use only genuine Charnwood replacement parts.

Fig. 6 Correct orientation of fuel retainer

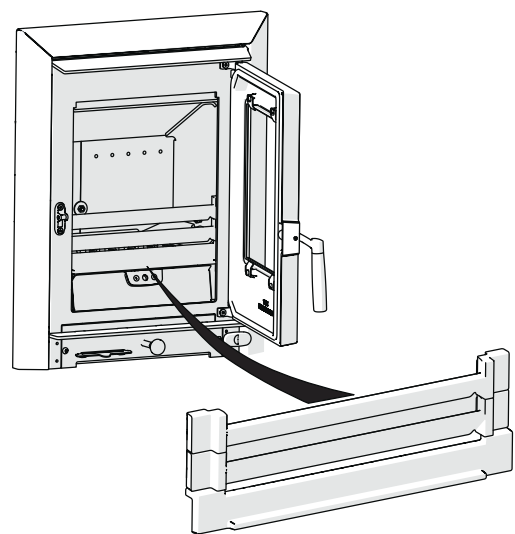

THROAT PLATE AND FLUEWAY CLEANING

It is important that the throat plate and all the stove flueways are kept clean in order to prevent potentially dangerous fume emission. They should be cleaned at least monthly, and more frequently if necessary. It is necessary to let the fire out to carry out these operations.

To remove the throat plate, slide it forward so that it clears the back brick, then slide it either right or left so that the opposite side clears the retaining flange on the side plate and can be gently lowered. Any sooty deposits should then be swept from the plate and into the fire.

To return the throat plate to its correct position, insert the throat plate so that it sits on either the right or the left retaining flange on the side plates. Raise the opposite side and adjust it so that the throat plate is central and supported by both side plates. Slide back so that the recessed edge at the back of the underside, rests neatly on the face of the back brick.



TROUBLESHOOTING

FIRE WILL NOT BURN

Check that:

- a) The air inlet is not obstructed in any way.
- b) Chimneys and flueways are clear.
- c) Well seasoned wood is being used as a fuel.
- d) There is an adequate air supply.
- e) An extractor fan is not fitted in the same room as the stove.
- f) There is sufficient draw in the chimney. Once the chimney is warm a draught reading of at least 1.25 mm (0.05 inches) water gauge (12Pa) should be obtained.

BLACKENING OF DOOR GLASS

Differences in chimney draughts mean that the best settings of the air controls will vary for different installations. A certain amount of experimentation may be required, however the following points should be noted and with a little care should enable the glass to be kept clean in most situations:

- a) Wet or unseasoned wood, or logs overhanging the front fence will cause the glass to blacken
- b) The airwash relies on a supply of heated air to keep the glass clean. Therefore, when lighting the stove, allow the firebed to become well established before closing the air control. This may also be necessary when re-fuelling the stove.
- c) When re-fuelling keep the fuel as far back from the front fence as possible. Do not try to fit too much fuel into the firebox.
- d) Do not completely close the air control.

It is always more difficult to keep the glass clean when running the stove very slowly for long periods.

If blackening of the glass still occurs check that all flue connections are well sealed. It is also important that the chimney draw is sufficient and that it is not affected by down-draught. When the chimney is warm a draught reading of at least 1.25 mm (0.05 inches) water gauge (12Pa) should be obtained. Some blackening of the glass may occur below the level of the fuel retainer. This will not obscure the view of the fire or affect its performance.

FIRE BLAZING OUT OF CONTROL

Check that:

- a) The door is tightly closed.
- b) The air control slider is fully closed.
- c) A suitable fuel is being used.
- d) Door seals and air control slider are intact.
- e) Undergrate plate is fitted.

FUME EMISSION

Warning Note: Properly installed and operated this appliance will not emit fumes. Occasional fumes from de-ashing and re-fuelling may occur. Persistent fume emission is potentially dangerous and must not be tolerated. If fume emission does persist, then the following immediate actions should be taken:

- a) Open doors and windows to ventilate the room.
- b) Let the fire out and safely dispose of the fuel from the appliance.
- c) Check for flue or chimney blockage, and clean if required.
- d) Do not attempt to re-light the fire until cause of fume has been identified. If necessary, seek professional advice.

The most common cause of fume emission is flueway or chimney blockage. For your own safety these must be kept clean.

CHIMNEY FIRES

If the chimney is thoroughly and regularly swept, chimney fires should not occur. However, if a chimney fire does occur close the air control, and tightly close the door of the appliance. This should cause the chimney fire to go out in which case the controls should be kept closed until the stove has gone out. The chimney and flueways should then be cleaned. If the chimney fire does not go out when the above action is taken then the fire brigade should be called immediately. After a chimney fire the chimney should be carefully examined for any damage. Expert advice should be sought if necessary.

IF YOU NEED FURTHER HELP

If you need further help with your Charnwood then your Installer will be able to provide the answers to most questions. Your Local Charnwood Premier Dealer has a great deal of experience and will also be able to provide helpful advice. Further help is available from the Charnwood Customer Services department who will be pleased to give advice, if necessary.

HEALTH AND SAFETY PRECAUTIONS

Please take care when installing the stove that the requirements of the Health and Safety at Work Act 1974 are met. Adequate facilities must be available for loading, unloading and site handling.

Some types of fire cement are caustic and should not be allowed to come into contact with the skin. In case of contact, wash with plenty of water.

If there is a possibility of disturbing any asbestos in the course of installation then please use appropriate protective equipment.

There must not be an extractor fan fitted in the same room as the stove as this can cause the appliance to emit fumes into the room.

The combustion air supply ducting must be connected to a suitable, permanently open air inlet. See 'Air supply' section for details. This stove is capable of intermittent operation. This stove is not suitable for use in a shared flue system.

In addition to these instructions the requirements of BS 8303 and BSEN 15287-1:2007 must be fulfilled. Local Authority Bylaws and Building Regulations, including those referring to national and European Standards, regarding the installation of Solid Fuel burning appliances, flues and chimneys must also be observed.

UNPACKING THE STOVE

The stove arrives bolted to its pallet and covered with a cardboard box. Remove the bands and lift off the box. Use a cross head screwdriver to remove the brackets fixing the stove to the pallet. Use a 10mm spanner or socket to remove the rear fixing bracket. The pallet is intended to be cut up and used for kindling fuel

AIR SUPPLY

The fire needs air for combustion, there are various ways of supplying this, and they must meet the requirements of the building regulations.

One way of meeting this requirement as outlined in Approved Document J is to have a permanently open air vent into the room. The Cranmore Insert has a 5kW output and therefore a permanent air vent is not normally required. If the air permeability is less than $5.0 \text{ m}^3/(\text{h}\cdot\text{m}^2)$ then the required minimum vent area will be $27.5 \text{ cm}^2(4.3\text{in}^2)$.

If using this method then the air supply ducting may be terminated

in the room, or the ducting connections on the stove can be removed from the inside and outside of the convection casing and the rear of the air box. The blanking plate should also be removed from underneath the air box and fitted in the place of the ducting connections on the rear of the convection casing. This is so that air is taken from between the fire box and the convection casing.

Alternatively a fixed ducted air supply method can be used as shown in fig. 12. One end of the air supply ducting is connected to the stove and the other is terminated outside. The ducting must be a minimum 80mm dia, non-combustible, less than 5.5m long and must not have more than five 90° bends and two 45° elbows. It must be sleeved where it passes through the external wall. The inlet must be permanently open and the duct free of any constrictions. The inlet must have a suitable grill to prevent entry by vermin, and should be positioned so that blockage by leaves or other debris will be avoided. Ensure that rain or flood water will not enter the duct. A spillage test must be carried out during commissioning to verify adequate air supply for combustion - see the section on Commissioning.

External air kits are available, please contact Charnwood for more information (Ref TIS 120)

CO ALARMS

Building regulations require that whenever a new or replacement fixed solid fuel or wood/biomass appliance is installed in a dwelling a carbon monoxide alarm must be fitted in the same room as the appliance. Further guidance on the installation of the carbon monoxide alarm is available in BS EN 50292:2002 and from the alarm manufacturer's instructions. Provision of an alarm must not be considered a substitute for either installing the appliance correctly or ensuring regular servicing and maintenance of the appliance and chimney system.

SPECIFICATIONS

	Wood logs
Output	5kW
Stove weight	105kg
Flue gas temperature	279°C
Flue gas mass flow	4.4g/s
Average refuelling cycle	0.75hrs
Min. flue draught	12Pa
CO at 13% O2	0.08%
Max. log size	300mm x 75mm

Fig. 7 Minimum distances from combustibles

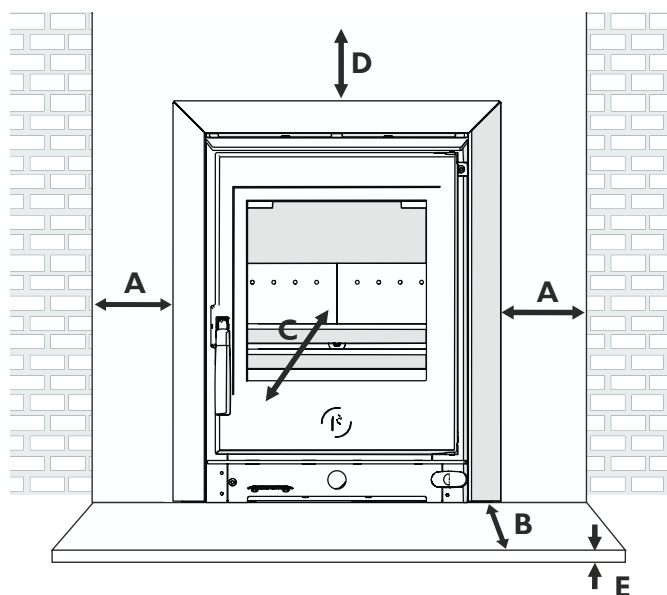

Dimension A: 280mm

Dimension B: 251mm (Building regulations)

Recommended: 390mm (extension of door over hearth)

Dimension C: 1000mm (in front of glass)

Dimension D: 310mm

Dimension E: 12mm

CHIMNEY

In order for the appliance to perform satisfactorily the chimney height must not be less than 4 metres measured vertically from the outlet of the stove to the top of the chimney. The internal dimensions of the chimney (either square or round) MUST NOT BE LESS THAN 127 mm (5 inches).

If an existing chimney is to be used it must be swept and checked, it must be in good condition, free from cracks and blockages, and should not have an excessive cross sectional area. If you find that the chimney is in poor condition then expert advice should be sought regarding the necessity of having the chimney lined. If it is found necessary to line the chimney then a lining suitable for Solid Fuel must be used.

If the stove has been fitted in the place of an open fire, it is recommended that the chimney is swept one month after installation to clear any soot falls which may have occurred due to the difference in combustion between the stove and the open fire.

If there is no existing chimney then a prefabricated block chimney or a twin walled insulated stainless steel flue to BSEN 15287-1:2007

can be used either internally or externally. It might be appropriate to prove the chimney function to EN13384-2:2015+A1:2019. National installation and building regulations should be met, often T400 G is required.

Single wall flue pipe is suitable for connecting the stove to the chimney but is not suitable for using for the complete chimney.

It is important that there is sufficient draw in the chimney and that the chimney does not suffer from down-draught. When the chimney is warm the draw should be not less than 1.25mm (0.05 inches) water gauge (12.pa). A draught sampling point is located on the top of the stove (see Fig. 8). If it is found that there is excessive draw in the chimney then a draught stabiliser should be fitted. If in doubt about the chimney seek expert advice.

Fig. 8 Draught sampling point (decorative trim removed)

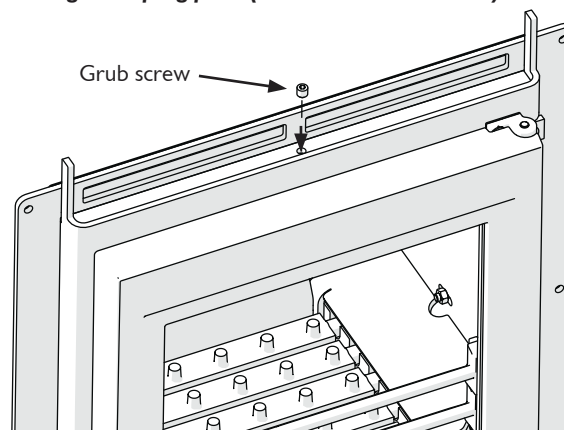

HEARTH AND FIRE SURROUND

The stove must be installed above a fireproof hearth in accordance with local building regulations (See Fig.7 for dimensions). If in doubt as to the positioning of the stove expert advice should be sought either from the supplier or the local building inspector.

The appliance should be installed on a floor with adequate load-bearing capacity. If an existing construction does not meet this requirement then please take suitable measures to achieve this. (e.g. load distributing plate.)

If a wooden mantelpiece or beam is used in the fireplace it should be a minimum of 310mm above the appliance. In some situations it may be necessary to shield the beam or mantelpiece to protect it.

In order for the appliance to fit into the fire surround there must be a flat area around the opening. Details are shown in Fig. 9.

PREPARATION OF FIREPLACE

If the fireplace contains combustible materials, inlet and outlet vents with an area of 246cm² each must be fitted below and above the stove convection case to provide a continual air flow around the stove. It is recommended that Calcium Silicate board is used (130mm board, with a 100mm air gap between the stove and the insulation (see Fig. 10).

Fig. 9 Limiting dimensions of surround and opening

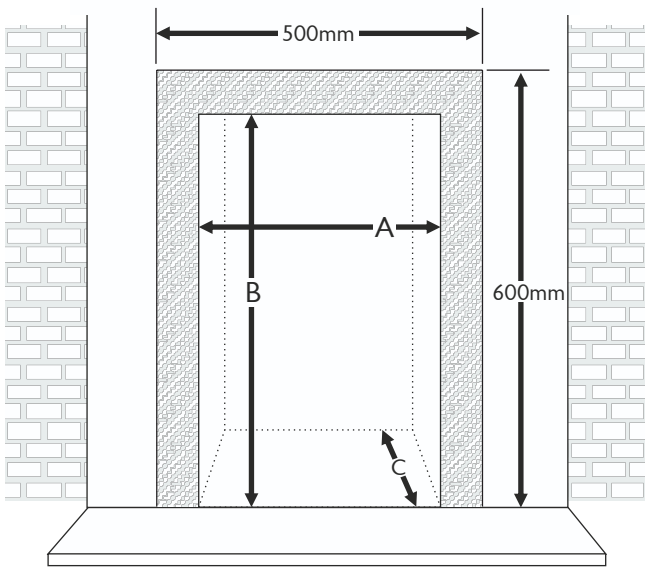

The shaded grey area on the face of the surround is the minimum flat area required for inset installation.

Dimension A	Dimension B	Dimension C
Min. 405mm	Min. 555mm	Min. 380mm
Max. 430mm	Max. 565mm	

If the fireplace does not contain combustible materials, it is still recommended to have a layer of insulation or ventilate the space between the casing and the outer wall. The insulation may consist of a layer of mineral fibre or calcium silicate board. Insert this into the opening before sliding in the convection casing.

Before fitting the appliance into an existing fireplace remove the fireback and any loose in-fill material.

The surround and opening for the appliance must conform with Fig.9. The flat area around the opening should be a minimum of 500mm wide and 600mm high. Ensure that the hearth and the base in the

opening are flat, level, and at right angles to the surround.

The air supply can be taken from using an external air kit or directly from the convection casing. The air supply kit can be fitted in the room or outside, in accordance with the requirements in 'Air Supply' section (p10). The inlet grille must not constrict the airflow through the duct and it must be permanently open. A semi rigid aluminium flexible duct of no less than 80mm diameter is used to bring the air to the stove. The duct must be less than 5.5m long, have no more than five 90° bends and two 45° elbows. The 80mm diameter spigot, provided with the stove should be fitted on the outside of the convection case, using two self tapping screws and the duct should be terminated on the spigot with a jubilee clip. The 100mm diameter spigot provided should be fitted to the inside of the convection case

Fig. 10 Fireplace with combustible material

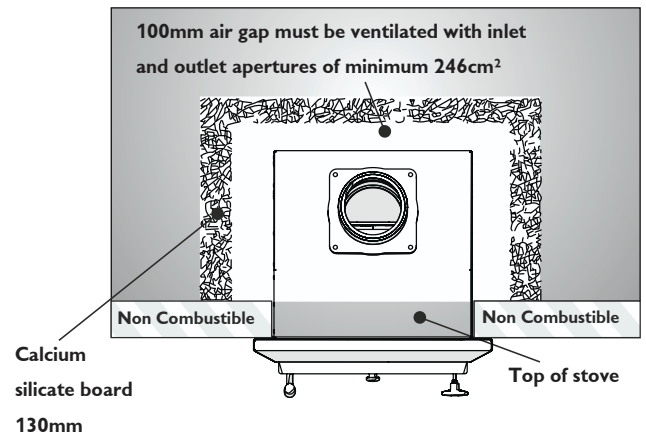
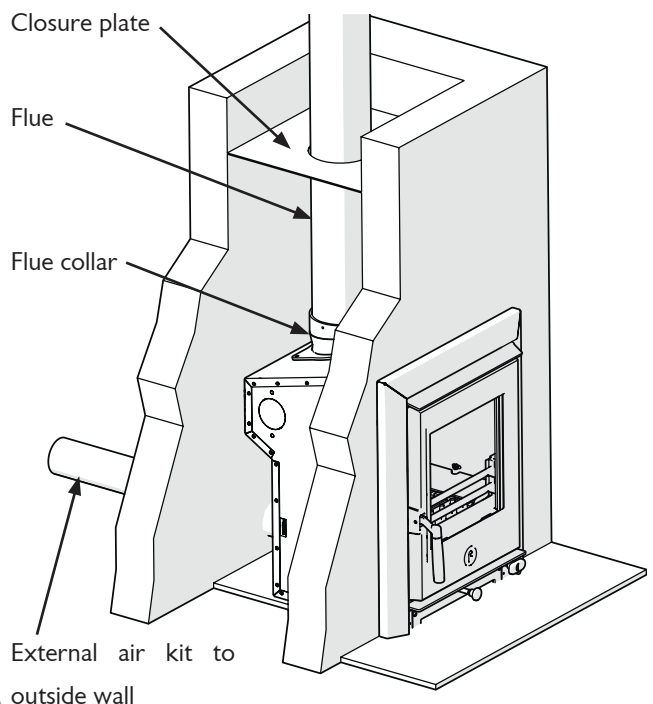

Fig. 11 Installation in standard chimney



using two nuts on the outside and the self adhesive foam should be glued into position around the circumference of the inside of the 80mm spigot in order to seal against the spigot on the back of the stove when it is installed.

A cover plate can be fitted to the rear outlet of the convection casing. The outlet on the rear of the air box is to be left open and no spigots are to be attached. This will provide external air directly from the convection casing.

Fig. 12 Air supply

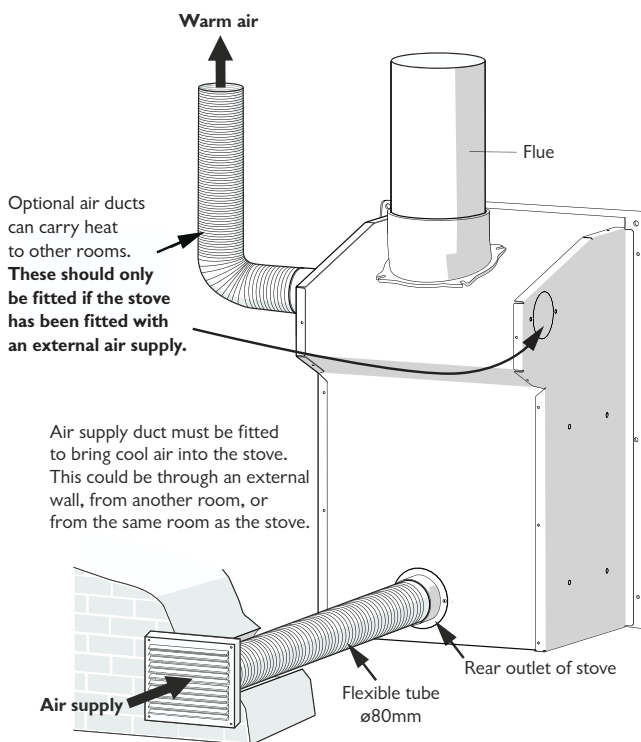

FITTING THE CONVECTION CASING, FLUE PIPE AND STOVE

Having prepared the fireplace as described, the convection case, stove and flue pipe can now be fitted.

1. ATTACH FLUE COLLAR TO THE FLUE PIPE

Some liner manufacturers recommended the use of a rigid pipe with the liner - please refer to the liner manufacturers instructions. Fix the upper flue collar to the flue pipe through the screw holes in the side of the ring. The flue collar can be attached at any of 4 positions depending on the required angle of the flue. (Fig. 13)

Fig. 13 Flue collar

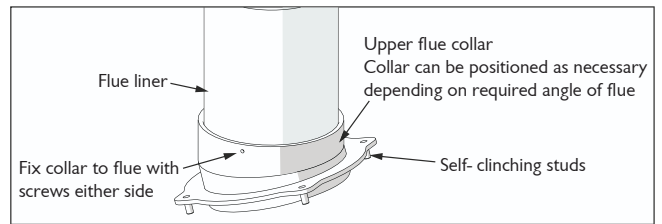

It is vital that the connections at both ends of the flue pipe are well sealed. The flue pipe and collar can be sealed with fire cement and/or a gasket.

2. INSERT THE CONVECTION CASING INTO THE OPENING

Make sure the four self-clinching studs are in the holes in the flue collar, pointing downwards. Slide the convection casing into position

Fig. 14 Convection casing

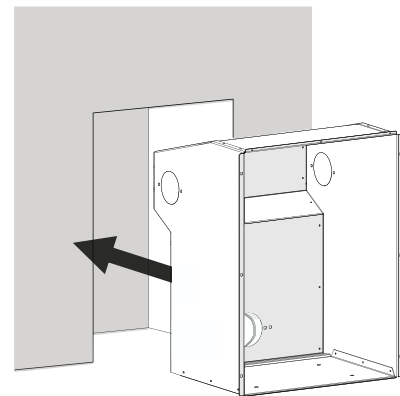

in the opening until the flue outlet lines up with the flue pipe. Any excess air ducting still in the opening can be pulled out at the external termination point and trimmed to fit the grille selected. Ensure that the air supply duct is not kinked during the fitting process. (Fig. 14)

3. MAKE FLUE CONNECTION

Fig. 15 Flue collar to casing

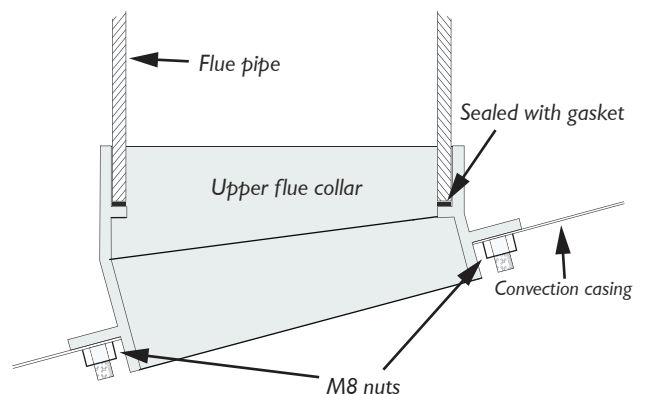

INSTALLATION INSTRUCTIONS



Reaching through the flue outlet, bring the flue collar down through the outlet until the studs line up with the four holes in the convection casing. Use 4 x M8 nuts to secure the studs into place. (Fig 15)

4. SECURE THE CASING TO THE HEARTH

Use holes in the base and side flanges of the convection casing to secure with screws if required. (Fig. 16)

5. MAKE GOOD THE OPENINGS AND FILL WITH

Fig. 16 Secure casing

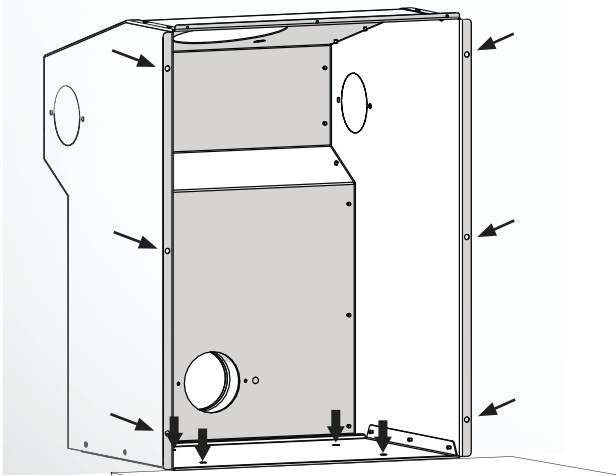

INSULATION

Make good the opening at the top and sides of the convection casing ensuring that a good seal is made with the side flanges. It is recommended to use heat resistant plaster on the wall surrounding the stove.

Follow the liner manufacture's recommendations regarding insulating the liner.

Fig. 17 Fit coach bolts

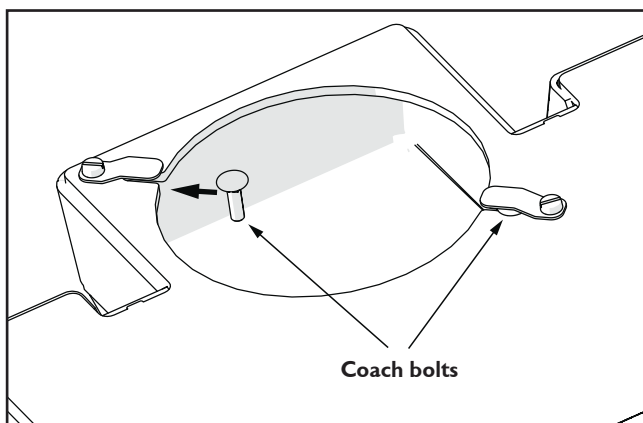

If for any reason it is not going to be possible to sweep the chimney through the appliance, a soot door must be fitted.

6. POSITION COACH BOLTS IN STOVE

Fit 2 x (M6 x 20mm) coach bolts under the clips either side of the flue exit at the back of the firebox. These will secure the inner flue collar (Fig. 17)

7. SLIDE IN STOVE

Fig. 18 Insert stove

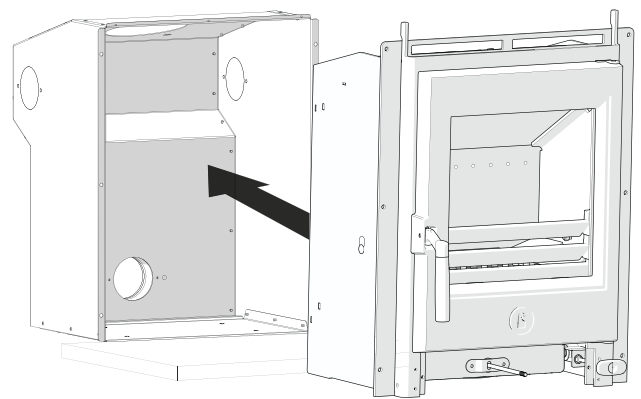

With the external frame and lower trim removed, carefully slide the stove into the convection casing until the flue outlet lines up with the flue collar and the air inlet engages at the rear of the stove. Use holes on stove side flanges to secure to the wall if necessary. (Fig. 18)

8. SECURE THE FLUE COLLAR

Working from the inside of the stove, push the inner flue collar up through the flue outlet to meet the upper flue collar, so that the coach bolts come down through the holes. Secure bolts with M6 nuts.

All flue connections must be well sealed. Check that the flue pipe is not obstructed or restricted in any way and that all joints are well sealed. (Fig. 19)

9. ATTACH TRIM

Fit the frame trim over the hooks on the stove and secure with 2 x M4 screws at the bottom. (Fig 20/ 21)

Fig. 19 Connect inner flue collar

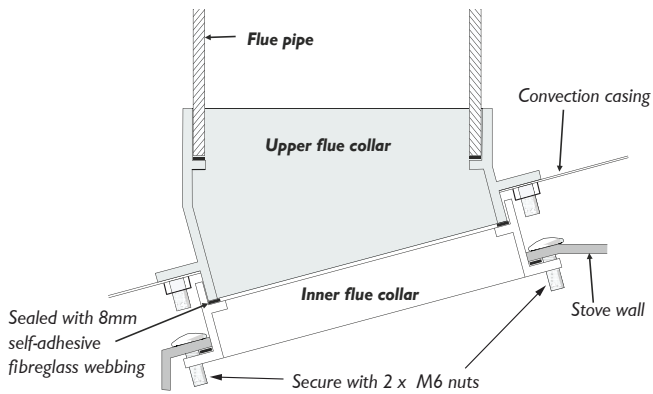

10. RE - ATTACH LOWER TRIM

Fig. 20 Attach trim

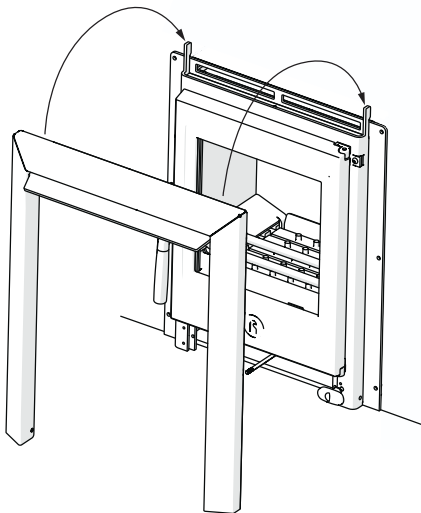

Fig. 21 Secure trim

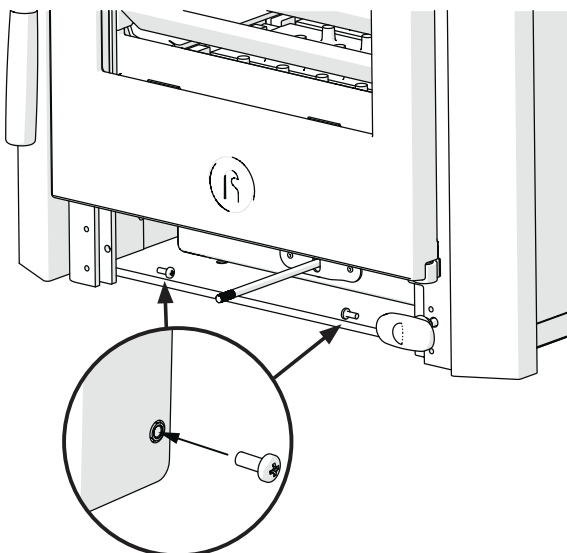

Fig. 22 Lower trim

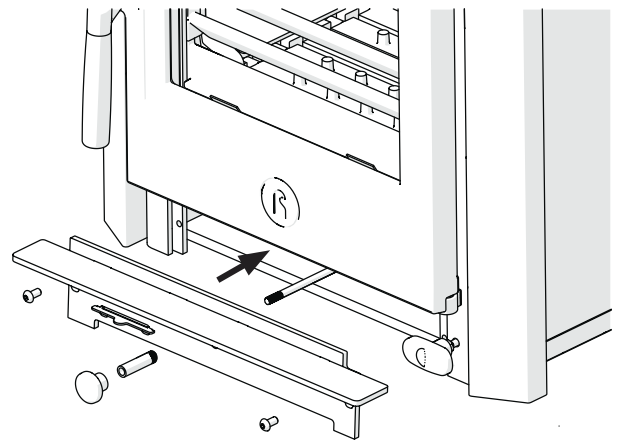
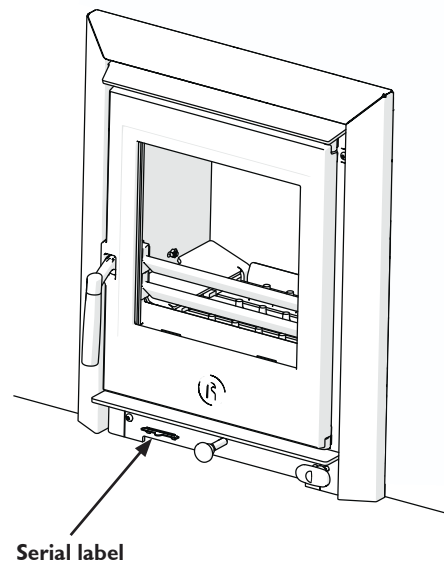

Fig. 23 Stove installed



Re-attach lower trim, air control knob and air control stop. Make sure this is secure and that the air control is moving freely. (Fig 22)

PRE LIGHTING CHECK

Before initial lighting check the following points:

1. The bottom grate bars must all be fitted and should move freely and easily when the riddling mechanism is operated.
2. The plates round the sides and back of the grate must be in position and sitting correctly.
3. The throat plate must be fitted in the roof of the appliance (as shown in Fig. 5).



4. Check that the front fence is fitted correctly and that the door closes properly.

COMMISSIONING

On completion of the installation allow a suitable period of time for the fire cement and mortar to dry out before commissioning the fire. Before lighting, first check that there is an updraft in the chimney - open the door of the stove and hold a lit match at the top of the door opening. If the flame is pulled into the stove this indicates that there is an updraft and the fire may be lit. If the flame is pushed out from the stove then this indicates that a downdraft is present, the flue will need to be warmed to produce an updraft and then checked using the same procedure with the lit match. The flue may be warmed by lighting a single sheet of newspaper, or a firelighter, within the stove before attempting to light a proper fire. Sometimes it may be necessary to open a window to give an initial draw.

A spillage test must be carried out to confirm safe operation with doors and windows closed and any extract fans in operation (i.e. worst conditions). Warm the appliance and flue before carrying out the spillage test. Light a smoke match from the middle of a bed of embers, hold the match approximately 20mm above the ember bed and ensure that the smoke is carried up the flue and emitted safely. Also check all joints and seals. On successful completion of the spillage test please leave the operating instructions and tools with the customer and advise them on the use of the appliance. If the spillage test fails the cause must be found and rectified, or the appliance decommissioned and the customer instructed not to use the appliance until it can be shown to operate safely.

CAA AND SMOKE CONTROL

The Clean Air Act 1993 and Smoke Control Areas

Under the Clean Air Act local authorities may declare the whole or part of the district of the authority to be a smoke control area. It is an offence to emit smoke from a chimney of a building, from a furnace or from any fixed boiler if located in a designated smoke control area. It is also an offence to acquire an "unauthorised fuel" for use within a smoke control area unless it is used in an "exempt" appliance ("exempted" from the controls which generally apply in the smoke control area).

In England appliances are exempted by publication on a list by the Secretary of State in accordance with changes made to sections 20 and 21 of the Clean Air Act 1993 by section 15 of the Deregulation Act 2015. Similarly in Scotland appliances are exempted by publication

on a list by Scottish Ministers under section 50 of the Regulatory Reform (Scotland) Act 2014.

In Northern Ireland appliances are exempted by publication on a list by the Department of Agriculture, Environment and Rural Affairs under Section 16 of the Environmental Better regulation Act (Northern Ireland) 2016.

In Wales appliances are exempted by regulations made by Welsh Ministers.

Further information on the requirements of the Clean Air Act can be found here: <https://www.gov.uk/smoke-control-area-rules>

Your local authority is responsible for implementing the Clean Air Act 1993 including designation and supervision of smoke control areas and you can contact them for details of Clean Air Act requirements.

The Cranmore Insert has been recommended as suitable for use in smoke control areas when burning wood logs. The stove includes a factory-fitted modification to the air control to prevent complete closure of the air supply. Suitable Authorised fuels can also be burned within Smoke Control Areas. A list of Authorised fuels can be found here: <https://smokecontrol.defra.gov.uk/fuels.php>.

APPLIANCE LIFESPAN

This appliance is designed to provide many years of service. Worn or damaged parts can be replaced - see page 19 for details.

This appliance is comprised of predominantly metal parts which can be recycled. Other components such as the ceramic glass, firebrick and glass gaskets cannot be easily recycled.

CHIMNEY SWEEPING

The chimney should be swept at least twice a year. It will generally be possible to sweep the chimney through the appliance.

First remove the fuel retainer and the throat plate. Then sweep the chimney ensuring that soot is removed from all horizontal surfaces after sweeping.

In situations where it is not possible to sweep through the appliance the installer will have provided alternative means, such as a soot door. After sweeping the chimney the appliance flue outlet and the flue pipe connecting the stove to the chimney must be cleaned with a flue brush. After clearing any soot from within the stove, replace the throat plate (Fig. 5) and the fuel retainer (Fig. 6). The fuel retainer in



made up of three separate parts.

Different types of sweep's brushes are available to suit different flueways. For prefabricated insulated chimneys the manufacturers instructions with regard to sweeping should be consulted.

CO ALARM

Your installer should have fitted a CO alarm in the same room as the appliance. If the alarm sounds unexpectedly, follow the instructions given under "Fume Emission".

To replicate the nominal performance results obtained in the type test, the following parameters must be used:

Air Setting: Nominal (1 click in from max out).

Basic Firebed: 0.48kg.

Kindling: 0.28kg, small section pine kindling started with door cracked to start

Heavy Kindling: 1.73kg of heavier section Beech wood. Door cracked to start.

Pretest: 1.16kg, 2 x 28cm Beech logs arranged parallel to front. Door not cracked

Main Tests: 1.1kg, 1 x 27cm Beech log positioned parallel to front. Door not cracked

Beech Test Fuel Moisture Content: 13.3%

DIMENSIONS

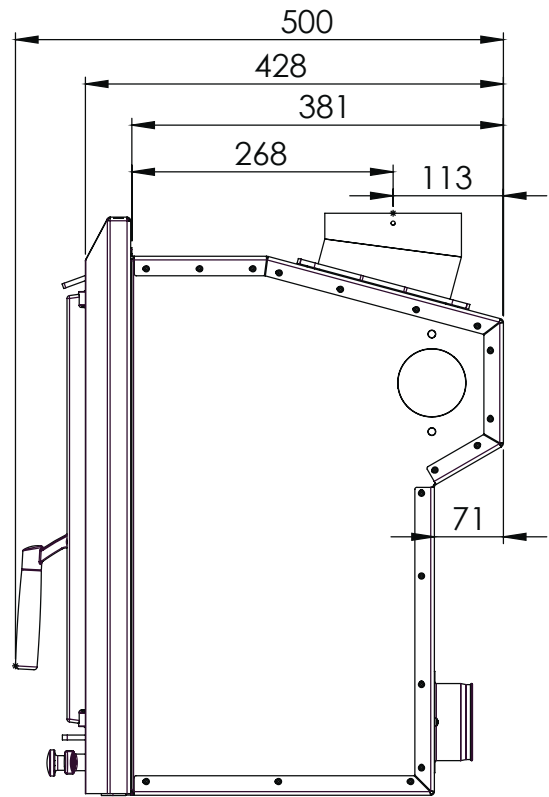
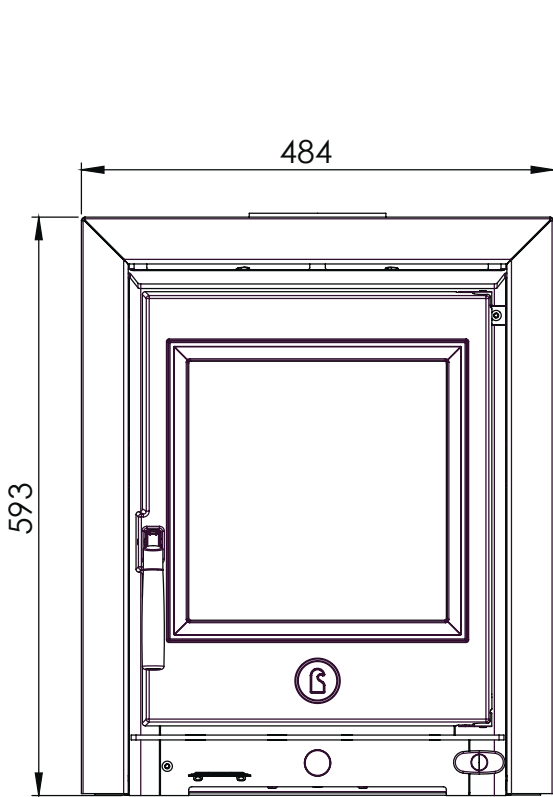

To fit 5inch (125mm) flue

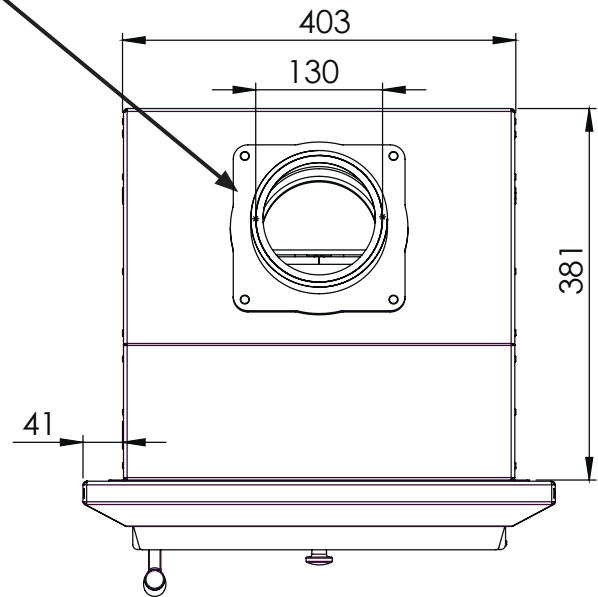
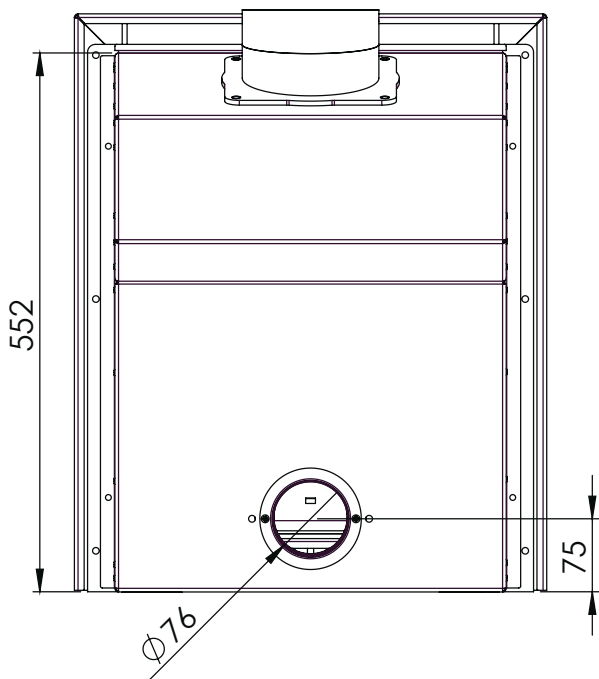



Issue D

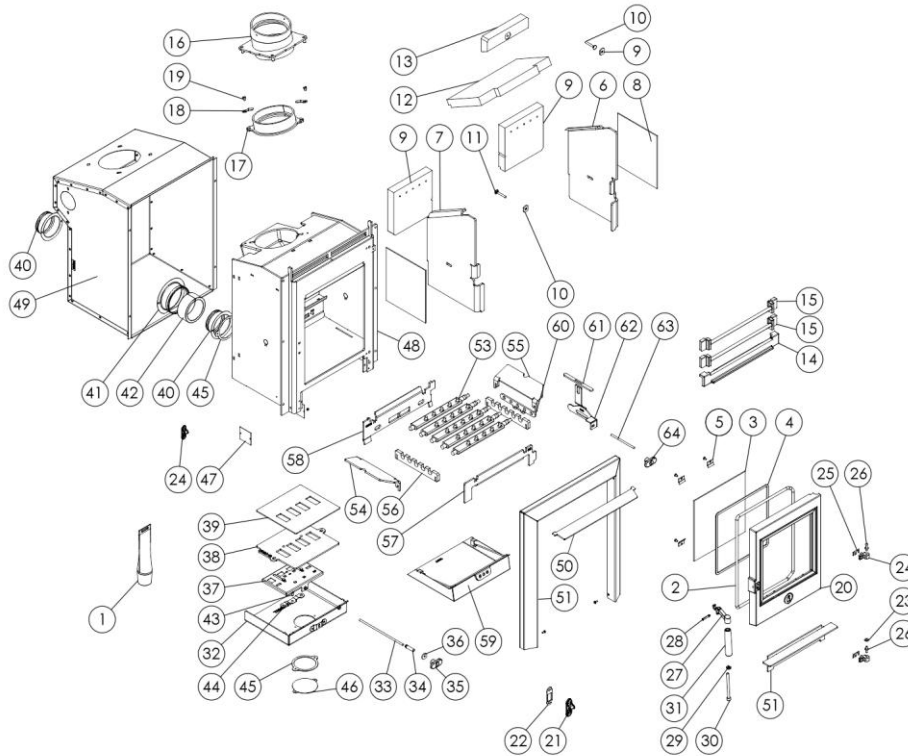

Item	Part No.	Description	Item	Part No.	Description
1	008/TH085	Door Seal Adhesive	34	008/TR047	DEFRA Stop
2*	008/BR038	Door Seal	35	008/AY37	Air Control Knob
3	006/PV19	Glass	36	008/BR052	Felt Washer
4*	008/PV55	Glass Seal Kit	37	004/TR007	Air Inlet Slide
5	004/KV23	Glass Retainer	38	010/CR005	Air Control Plate
6	010/TT027	RH Sideplate	39	008/CR006	Air Box Gasket(Upper)
7	010/TT028	LH Sideplate	40	010/CR048/S	Air Inlet Spigot
8	011/PV26	Side Ceramic Gasket	41	010/MR126	100mm Spigot
9	011/TR029S	Rear Brick Set	42	008/GR072	Gasket
10	010/ER036	Brick Retaining Washer	43	008/ES36/01	Brass Ball Catch
11	008/FFB125	M6 x 45 Coach Bolt	44	004/BR015	Clicker Retainer Plate
12	011/TR031	Brick Throat Plate	45	008/CR063	Blanking Plate Gasket
13	011/TR032	Upper Throat Plate Brick	46	004/CR064	Coverplate
14	002/TT007	Front Fence	47	012/TT011	Serial No. Label
15	002/TT008	Deepening Bar	48#	001/TT010	Firebox
16	010/TR098	5" Upper Flue Adaptor	49	010/TR084	Convection Casing
17	010/TR076	Lower Flue Adaptor	50#	010/TT052	Louvre
18	004/GR090	Fastener Retainer	51#	005/TT051	Trim Frame
19	008/FFS006	M6x10 Sstd Cheese Hd Screw	52#	010/TT021	Front Lower Trim
20#	003/TT001/A	Door Assembly	53	002/CG01	Bottom Grate Bar
21	004/BR084	Door Latch	54	010/GR057	LH Grate Plate
22	004/BR088	Door Latch Packer	55	010/GR056	RH Grate Plate
23	008/FFW026	1/4" Heavy Brass Washer	56	010/GR006	Grate Support
24	002/BR020	Hinge	57	010/GR042	Front Grate Support
25	004/BR021	Hinge Shim	58	010/TR048	Rear Grate Support
26	008/ST068/2	Hinge Pin Set	59	004/TR017	Ashpan
27	002/BR087	Handle Casting	60	010/TR040	Mover Bar
28	004/BR014	Handle Pivot Pin	61	010/TR045	Riddler Arm Cover
29	008/FFW015	Thackery Washer	62	010/TR042	Riddler Slide
30	008/FFB007	M8 x 100 Allen Hd Bolt	63	004/TR044	Riddler Rod
31	008/BR013	Wooden Door Handle	64	002/MR067	Air Control Knob
32	010/TR020	Air Box Cover Plate	65*	008/PX95	Ashpan Tool
33	004/GR086	Air Control Rod			

* These items are not shown on the drawing.
 # Please specify colour when ordering. Prices are shown in pounds sterling with vat at 20% They

To obtain spare parts please contact your local stockist giving Model, Part No. and Description. In case of difficulty contact the manufacturer at the address



charnwood



AJ WELLS & SONS LTD

Bishops Way, Newport, Isle Of Wight PO30 5WS, United Kingdom
A Division of A.J.Wells & Sons Limited Registered In England No. 03809371



EN16510-1:2022 / EN16510-2-2:2022

INSET APPLIANCE

Model:	Cranmore Insert
EC Certificate of conformity no:	TT11-CPD-2024
Fuel type:	WOOD LOGS
Rated space heating thermal output:	5kW
Emission of CO in combustion products:	0.08%
Mean flue gas temperature:	279 °C
Energy efficiency:	80%
Particles (mg/m ³)	13mg/Nm ³
Minimum distance to combustible materials:	
Casing side:	100mm + 130mm insulation
Casing rear:	100mm + 130mm insulation
Front surround side:	280mm
Front surround above:	310mm
Room, in front of glass:	1000mm
Fulfilled requirements: BStV of the City of Munich and the City of Regensburg FBStVO of the City of Aachen and the City of Düsseldorf 1.and 2. level of 1. BlmSchV of Germany	✓

All product related data available here:

<https://www.charnwood.com/conformance-documentation>

your premier dealer

charnwood BISHOPS WAY, NEWPORT, ISLE OF WIGHT PO30 5WS, UNITED KINGDOM
TEL. +44 (0) 1983 537777 • FAX. +44 (0) 1983 537788 • WWW.CHARNWOOD.COM

A Division of A.J.Wells & Sons Limited Registered in England No. 03809371