

EU
SCAN
79

EU - ASSEMBLY AND INSTRUCTIONS MANUAL

SCAN 79



ASSEMBLY AND INSTRUCTIONS MANUAL SCAN 79

CONGRATULATIONS ON YOUR NEW SCAN WOOD-BURNING STOVE

You have purchased a product by one of Europe's leading manufacturers of wood-burning stoves, and we are sure that you will have years of pleasure from your purchase.

To make the best possible use of your stove, it is important that you follow our advice and instructions. Read through this Assembly and Instruction Manual carefully before you start to assemble your stove.

SCAN 79
1250 MM



SCAN 79
WALL-HUNG



TABLE OF CONTENTS

TECHNICAL DATA			4
Installation	4	Product registration number	8
Safety	4	Dimension sketch	9
Technical data	6	Minimum distances	10
Type plate	8		
ASSEMBLY			11
Tools needed for mounting of the stove	11	Safety distance	13
Loose parts	11	Removal of packaging	14
Additional accessories	11	Removal of transport protection	15
Disposal of packaging	11	Height adjustment of stove	16
Room requirements	11	Door (Self-closing)	17
Fresh air intake	12	Fitting the side plates	18
Closed combustion system	12	Fitting the flue connection piece	19
Existing chimney and pre-fabricated element chimney	13	Mounting of wall-hung model	21
Connection between stove and steel chimney	13	Load-bearing foundation	24
Requirements for chimney	13	Floor plate	24
Requirements for insulated chimney	13		
INSTRUCTIONS FOR USE			25
CB-technology (Clean Burn)	25	Manual air control	26
Baffle plates	25	Ash container	26
INSTRUCTIONS FOR HEATING			27
First heating and paint hardening	27	Using the stove in various weather conditions	28
Environmentally-friendly firing	27	Firing in the spring or autumn	28
Lighting	27	The function of the chimney	29
Refuelling criteria	28	Chimney fire	29
Warning about over-firing	28	General notes	29
HANDLING OF THE FUEL			30
Selecting wood/fuel	30	Moisture	30
Preparation	30	Use of the following as fuel is illegal	30
Storing	30	Calorific value of the wood	30
MAINTAINANCE			31
Sweeping the chimney and cleaning the stove	31	Painted surfaces	31
Checking the stove	31	Removal of baffle plates and combustion chamber lining	32
Servicing	31	Cleaning the glass	34
Combustion chamber lining	31	Disposal of stove parts	34
Gaskets	31		
TROUBLESHOOTING			35
WARRANTY			36

TECHNICAL DATA

INSTALLATION

- All local regulations, including those referring to national and European Standards as well as the information provided in this assembly and instruction manual need to be complied with when installing the appliance
- When you install any kind of fireplace or stove, you must inform the local building and housing authorities. In addition you are obliged to have the installation inspected and approved by a local chimney sweep prior to commissioning
- To ensure best-possible functionality and safety for your installation, we advise you to call a professional fitter. Your Scan Dealer will be able to recommend a qualified fitter in your area. For information on Scan Dealers, please go to www.scan-stoves.com

SAFETY

Any changes made to the product by the dealer, fitter or user could result in the product and safety functions not functioning as intended. The same applies to the fitting of accessories or extra equipment not supplied by Scan A/S. This could also be the case if parts that are necessary for the operation and safety of the stove are dismantled or removed.



■ PLEASE NOTE!

YOU GET THE BEST USE OF
THE STOVE BY USING
A TOP-DOWN
LIGHTING METHOD

SEE
"INSTRUCTIONS FOR HEATING"



TECHNICAL PARAMETERS FOR SOLID FUEL LOCAL SPACE HEATERS
 REG. (EU) 2015/1185, REG. (EU) 2015/1186

Model identifier(s): Scan 79									
Indirect heating functionality				No					
Direct heat output...(kW)				6.5					
Indirect heat output...(kW)				N.A.					
						Emissions from space heating at nominal heat output			
						PM	OGC	CO	NO_x
Fuel						[X] mg/Nm ₃ (13 % O ₂)			
Wood logs with moisture content < 25%				Yes	No	25	57	622	86
Compressed wood with moisture content < 12%				No	No				
Other woody biomass				No	No				
Anthracite and dry steam coal				No	No				
Hard coke				No	No				
Low temperature coke				No	No				
Bituminous coal				No	No				
Lignite briquettes				No	No				
Peat briquettes				No	No				
Blended fossil fuel briquettes				No	No				
Other fossil fuel				No	No				
Blended biomass and fossil fuel briquettes				No	No				
Other blend of biomass and solid fuel				No	No				
Characteristics when operating with the preferred fuel									
Seasonal space heating energy efficiency η_s [%]				69					
Energy Efficiency Class				A					
Energy Efficiency Index (EEI)				105					
Item	Symbol	Value	Unit	Item	Symbol	Value	Unit		
Heat output				Use efficiency (NCV as received)					
Nominal heat output	P _{nom}	6.5	kW	Useful efficiency at nominal heat output	$\eta_{th, nom}$	79	%		
Minimum heat output (indicative)	P _{min}	N.A.	kW	Useful efficiency at minimum heat output (indicative)	$\eta_{th, min}$	N.A.	%		
Auxiliary electricity consumption				Type of heat output/room temperature control (select one)					
At nominal heat output	el _{max}	x,xxx	kW	single stage heat output, no room temperature control		[yes/no]			
At minimum heat output	el _{min}	x,xxx	kW	two or more manual stages, no room temperature control		[yes/no]	Yes		
In standby mode	el _{SB}	x,xxx	kW	with mechanic thermostat room temperature control		[yes/no]			
				with electronic room temperature control		[yes/no]			
				with electronic room temperature control plus day timer		[yes/no]			
				with electronic room temperature control plus week timer		[yes/no]			
				Other control options (multiple selections possible)					
				room temperature control, with presence detection		[yes/no]			
				room temperature control, with open window detection		[yes/no]			
				with distance control option		[yes/no]			
Permanent pilot flame power requirement									
Pilot flame power requirement (if applicable)	P _{pilot}	N.A.	kW						
Contact details	Name and address of the supplier:  Lena Bergqvist, (COO) Jøtul AS								

TECHNICAL DATA

Test in compliance with EN 16510		
	Classification of appliance	Type BF
P_{nom}	Nominal heat output	6.5 kW
P_{part}	Part load heat output	4.6 kW
η_{nom}	Energy efficiency at nominal heat output	79 %
η_{part}	Energy efficiency at part load heat output	81 %
$\eta_{s, nom}$	Seasonal space heating energy efficiency at nominal heat output	69 %
EEL_{nom}	Energy efficiency index at nominal heat output	105
	Energy efficiency class at nominal heat output	A
	Fuel	Wood*
	Fuel length, maximum	330 mm
$M_{h, nom}$	Fuel consumption at nominal heat output	1.9 kg/h
	Amount of fuel at nominal heat output	1.4 kg
	Amount of fuel, maximum	2.1 kg
CO_{nom}	CO emission at 13% O ₂ at nominal heat output	0.068 % 622 mg/Nm ³
CO_{part}	CO emission at 13% O ₂ at part load heat output	0.145 % 1428 mg/Nm ³
$NO_{x, nom}$	NO _x emission at 13% O ₂ at nominal heat output	86 mg/Nm ³
$NO_{x, part}$	NO _x emission at 13% O ₂ at part load heat output	88 mg/Nm ³
OGC_{nom}	OGC emission at 13% O ₂ at nominal heat output	57 mg/Nm ³
OGC_{part}	OGC emission at 13% O ₂ at part load heat output	109 mg/Nm ³
PM_{nom}	Dust emission at 13% O ₂ at nominal heat output	25 mg/Nm ³
PM_{part}	Dust emission at 13% O ₂ at part load heat output	11 mg/Nm ³
p_{nom}	Flue draught at nominal heat output	12 Pa
p_{part}	Flue draught at part load heat output	8 Pa
	Recommended sub-pressure in the connecting piece	18-20 Pa
	Required combustion air supply	16 m ³ /h
$T_{fg, nom}$	Flue gas temperature at nominal heat output	295 °C
$T_{fg, part}$	Flue gas temperature at part load heat output	248 °C
$T_{s, nom}$	Temperature in the flue connecting piece at nominal heat output	354 °C
T class	Chimney designation	T400 G
$\varnothing_{f, g, nom}$	Flue gas mass flow at nominal heat output	5.8 g/sec
$\varnothing_{f, g, part}$	Flue gas mass flow at part load heat output	4.2 g/sec
V_h	Standing air loss	0 m ³ /h
	Leakage before testing at a gauge pressure of 5 Pa	1.08 m ³ /h
	Leakage before testing at a gauge pressure of 10 Pa	2.18 m ³ /h
	Leakage before testing at a gauge pressure of 15 Pa	3.29 m ³ /h
CON/INT	Continuous operation (CON)/Intermittent operation (INT)	INT**
	Reaction to fire classification	A1

* Use only recommended fuels - designation I.

** Intermittent operation in this context means normal use of a wood-burning stove. In other words, you should let the fire die down until only the embers are left before refueling.

TECHNICAL DATA

Basic technical data

Materials	Stainless steel Cast iron Vermiculite Glass
Surface treatment	Senotherm
d_{out1}	Connecting piece int. diameter for outside flue pipe 144 mm
d_{out2}	Connecting piece ext. diameter for outside flue pipe 148 mm
d_{out3}	Connecting piece int. diameter for inside flue pipe 157 mm
d_{out4}	Connecting piece ext. diameter for inside flue pipe 161 mm
	Fresh air connection piece external diameter 100 mm
L	Overall dimensions (length) 378/395 mm
H	Overall dimensions (height) 1250/809 mm
W	Overall dimensions (width) 543 mm
m	Mass (weight) - Scan 79 (1250 mm/wall-hung) approx. 120/107,5 kg
m_{chim}	Maximum load of a chimney the stove may carry 120 kg

Minimum distances to combustible materials

d_R	Back (uninsulated/insulated flue pipe)	200/100 mm
d_S	Sides	450 mm
$d_{S(C)}$	Sides - corner distance (uninsulated/insulated flue pipe)	150/100 mm
d_C	Ceiling	750 mm
d_P	Front	1050 mm
d_F	Front to the bottom front radiation area	0 mm
d_L	Front to the side front radiation area	0 mm
d_B	Below the bottom (not regarding feet)	0 mm
d_{B1}	Bottom edge of door to floor	295 mm
d_{non}	Minimum distances to non-combustible walls	50 mm

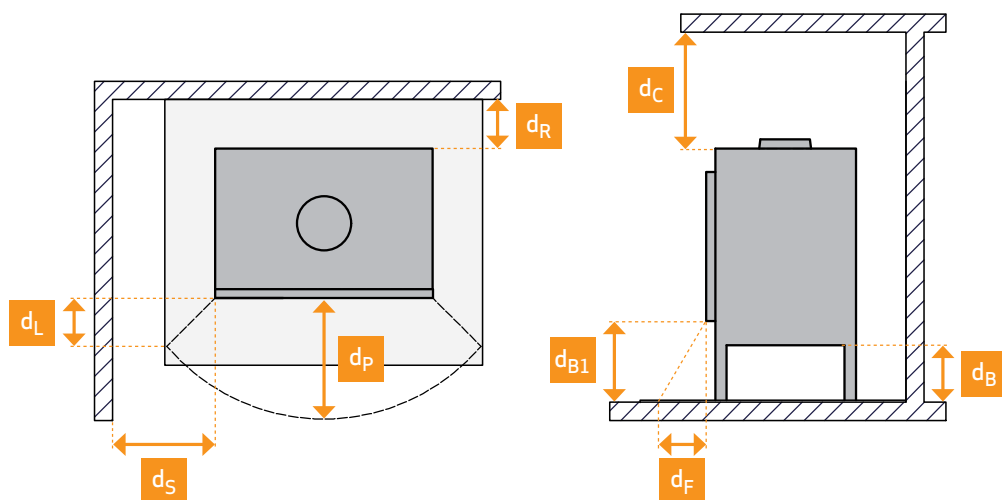

This stove is produced in accordance with type approval for the product, which also covers the product's Assembly and Instruction Manual. Read and follow the user operating instructions carefully.

The Declaration of Performance (DoP) is available from www.scan-stoves.com.

TYPE PLATE

All Scan wood-burning stoves are fitted with a type plate that specifies the approval standards and the distance to flammable materials.

The type plate is located at the rear of the stove.

Type plate

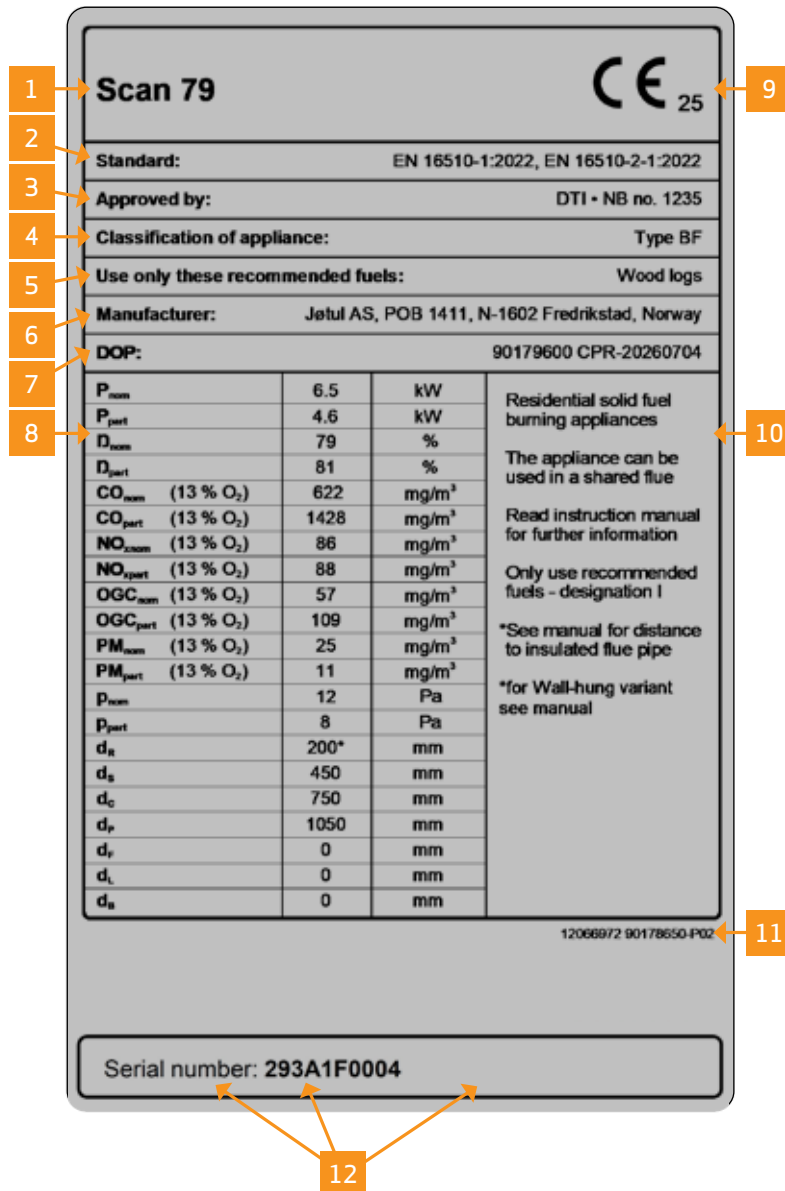

TYPE PLATE EXPLANATION

- 1 Type and/or the model number or designation to enable the appliance to be identified
- 2 Applicable standards
- 3 Name of test centre/certification number
- 4 Classification of appliance
- 5 Recommended fuels
- 6 Manufacturer's name and address
- 7 DOP document number
- 8 Table of values:

P_{nom} - nominal heat output

P_{part} - part load heat output

N_{nom} - energy efficiency at nominal heat output

N_{part} - energy efficiency at part load heat output

CO_{nom} - CO emission at 13 % O₂ at nominal heat output

CO_{part} - CO emission at 13 % O₂ at part load heat output

NO_{xnom} - NO_x emission at 13 % O₂ at nominal heat output

NO_{xpart} - NO_x emission at 13 % O₂ at part load heat output

OGC_{nom} - OGC emission at 13 % O₂ at nominal heat output

OGC_{part} - OGC emission at 13 % O₂ at part load heat output

PM_{nom} - dust emission at 13 % O₂ at nominal heat output

PM_{part} - dust emission at 13 % O₂ at part load heat output

p_{nom} - flue draught at nominal heat output

p_{part} - flue draught at part load heat output

Minimum distances to combustible material:

d_R - back

d_S - sides

d_C - ceiling

d_F - front

d_F - front to the bottom front radiation area

d_L - front to the side front radiation area

d_B - below the bottom (not regarding feet)

- 9 CE mark of conformity - The digits indicate the year of issue of the certificate
- 10 Product specifications and instructions
- 11 Type plate number
- 12 Product registration number

PRODUCT REGISTRATION NUMBER

All Scan wood-burning stoves are provided with a product registration number. This is unique to your stove and may need to be referred to when you contact Scan A/S or your dealer, e.g. for service or ordering spare parts.

We recommend taking a picture of the type plate and saving it digitally, or writing the number down in a safe place - e.g. together with your housing documents.

DIMENSION SKETCH

Scan 79 - 1250 mm

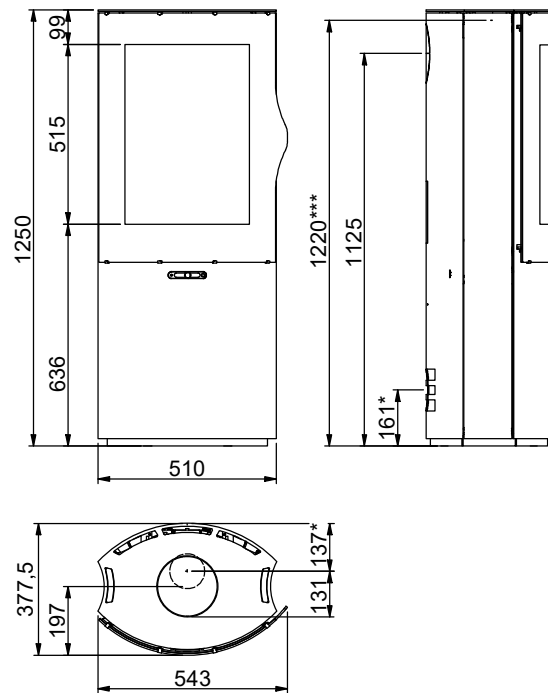

Scan 79 - wall-hung

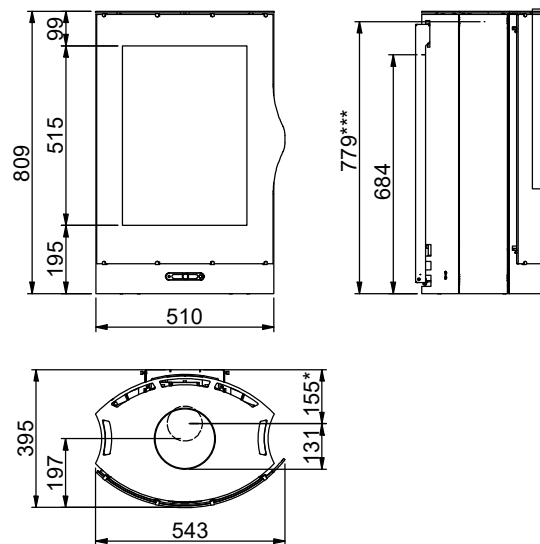

All distances are in mm.

All distances are minimum distances

* Connection of fresh-air intake \varnothing 100 mm

*** Height to the beginning of flue connecting piece at top outlet

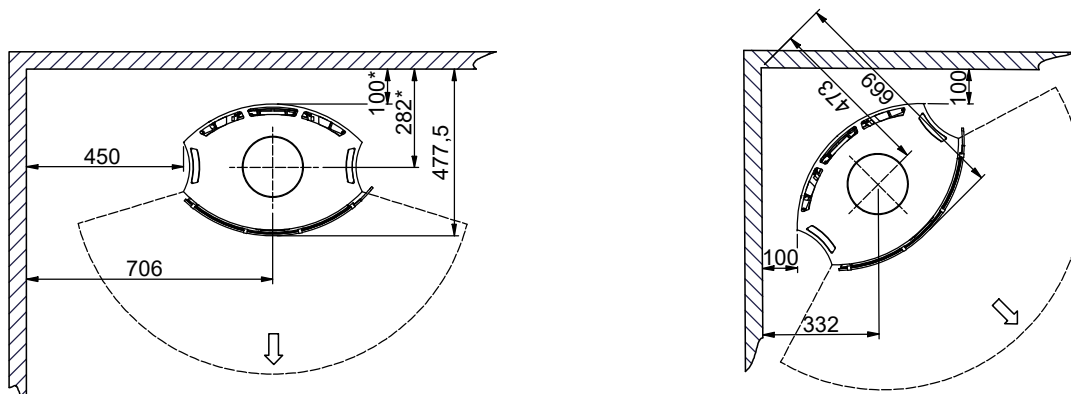

MINIMUM DISTANCES

Minimum distance to flammable materials

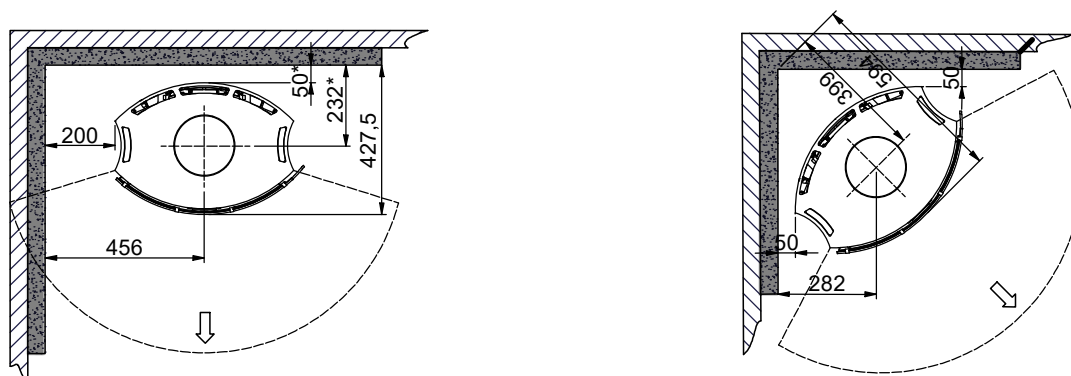

Minimum distance to flammable wall protected by a fire wall



-  Flammable material
-  Fire wall, e.g. 50 mm Jøtul Firewall, 110 mm brick or other material with corresponding fireproof and insulating abilities

All distances are in mm.

All distances are minimum distances

* Half-insulated chimney / shielded flue pipe (The requirements to the chimney and the flue pipe in terms of safety distances must be met)

ASSEMBLY

TOOLS NEEDED FOR MOUNTING OF THE STOVE

- Spirit level
- Cutting nippers
- Ø8 mm wall drill
- Combo wrench 8 mm
- 3 allen keys (2,5 mm, 4 mm & 5 mm)

LOOSE PARTS

In the stoves combustion chamber you will find the following loose parts:

- Glove
- Flue gas deflector plate for rear outlet
- Cover for top plate

ADDITIONAL ACCESSORIES

- Small shaped floor plate in glass
- Small shaped floor plate in glass for wall
- Large shaped floor plate in glass
- Connecting piece and seal and for rear outlet

DISPOSAL OF PACKAGING

Your Scan stove may come supplied with the following packaging:

Wood packaging	The wood packaging can be reused and after final use can be incinerated as a CO ₂ neutral product or sent for recycling
Foam	Send for recycling or waste disposal
Plastic bags	Send for recycling or waste disposal
Stretch/plastic film	Send for recycling or waste disposal

ROOM REQUIREMENTS

The stove must be installed in rooms with a good ventilation. A good ventilation is vital for the efficient operation of your stove.

We recommend installing smoke detectors in the home.

The distances specified in the manual only apply if you comply with the maximum amount of firewood. They only guarantee fire safety.

You should however assess whether furniture or other items might become excessively dry due to being too close to the stove. There is no guarantee that the present building materials can withstand the temperature in relation to visual changes.

- Check that Building Regulations and any local by laws are followed during installation

FRESH AIR INTAKE

In a well-insulated house, the air used up by the burning process has to be replaced. This particularly applies to houses with mechanical ventilation. There are different ways of making sure that an air exchange takes place. The most important thing is to ensure that there is a supply of air to the room where the wood stove is located. The external wall vent must be located as close to the wood stove as possible, and you must be able to close it when you are not using the wood stove.

National and local building regulations must be followed with regard to the connection of fresh-air intake.

CLOSED COMBUSTION SYSTEM

You should use the closed combustion system for the wood-burning stove if you live in a newly-built, airtight home. External combustion air is connected through a ventilation pipe via the wall or floor.

We recommend mounting a valve in the ventilation pipe in order to avoid condensate in the stove and the pipe system, when the stove is not in use. It can also be an advantage to insulate the ventilation pipe.

Minimum \varnothing 100 mm ventilation pipe, maximum length: 6 metres with a maximum of one bend. We recommend smooth steel pipes.

NOTE: if the stove has a fresh air connexion or closed combustion, the ventilation pipe must be open, when the stove is in use!

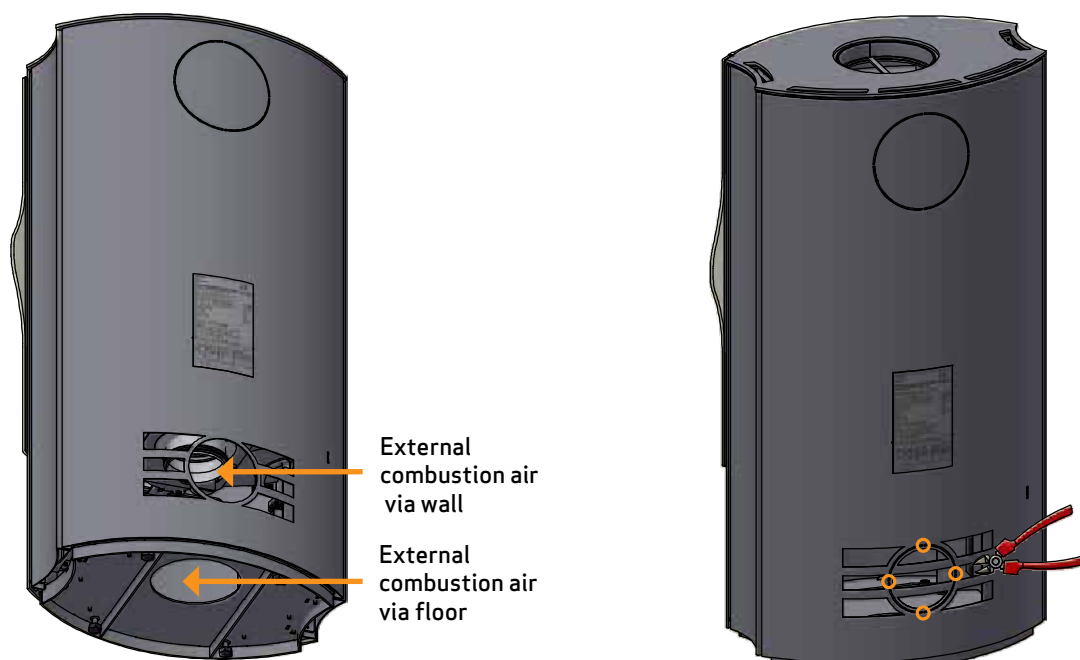

If you want external combustion air via a wall, remove the cover plate at the rear of the stove with a pair of cutting pliers

EXISTING CHIMNEY AND PRE-FABRICATED ELEMENT CHIMNEY

If you intend to connect your stove to an existing chimney, it makes sense to contact an authorised Scan dealer, or a local chimney sweep, for advice. These experts will also let you know if your chimney needs renovating.

- When connecting a pre-fabricated element chimney, follow the manufacturer's connection instructions for the relevant chimney type

CONNECTION BETWEEN STOVE AND STEEL CHIMNEY

Your Scan dealer, or local chimney sweep, can advise you on choosing a make and type of steel chimney. This ensures that the chimney will match your wood-burning stove.

REQUIREMENTS FOR CHIMNEY

The chimney must at least have a T400 designation, with G for the soot fire test. We recommend a chimney with a minimum internal diameter of 148 mm and a length of min. 4 metres.

If you opt to connect the stove with an elbow pipe, you should use a curved elbow, as this gives a better draught.

If you connect the stove with a sharp elbow pipe, the cleansing lid must be placed in the vertical part so that the horizontal part can be cleaned through here.

If the chimney is fitted with a smoke extractor, it must be possible to adjust it to a suitable draft.

The appliance can be installed in a shared flue, if the chimney is dimensioned for it.

The requirements to the chimney and the flue pipe in terms of safety distances must be met. The chimney shall be proven according to EN 13384-2:2015+A1:2019 depending on the individual situation on site.

- Choosing the wrong length or diameter of chimney could impair functionality
- Always comply exactly with the instructions provided by the chimney supplier



REQUIREMENTS FOR INSULATED CHIMNEY

The insulation level for insulated chimney: T400-N1-D-Vm-L50050-G100.
The air gap should be 10-15 mm.

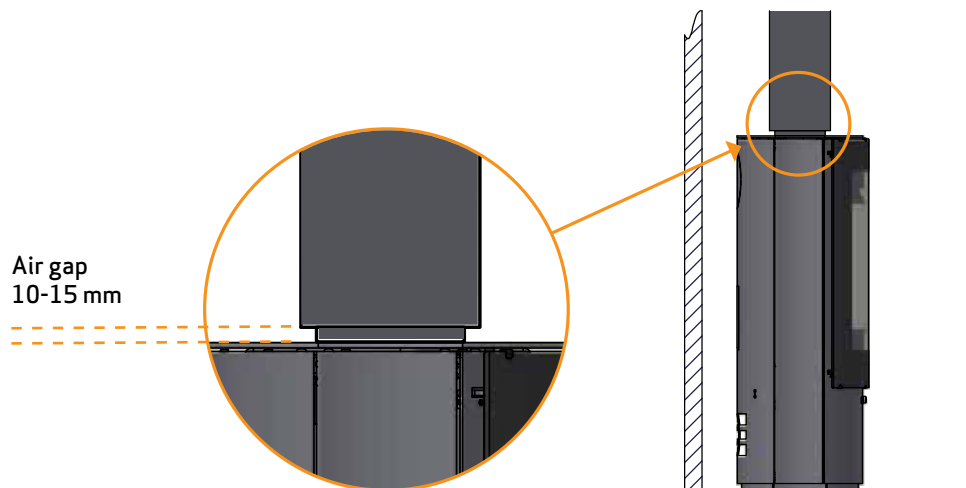

SAFETY DISTANCE

European, national and local regulations concerning safety distances for wood-burning stoves must be complied with.

There are no demands concerning the distance to non-flammable materials, but we recommend a distance of 50 mm in order to facilitate the cleaning of the stove, the flue pipes and the chimney and to prevent possible damages to the wall.

REMOVAL OF PACKAGING

Check that the stove is not damaged before starting to install it.
The stove comes attached to a wooden pallet on delivery.

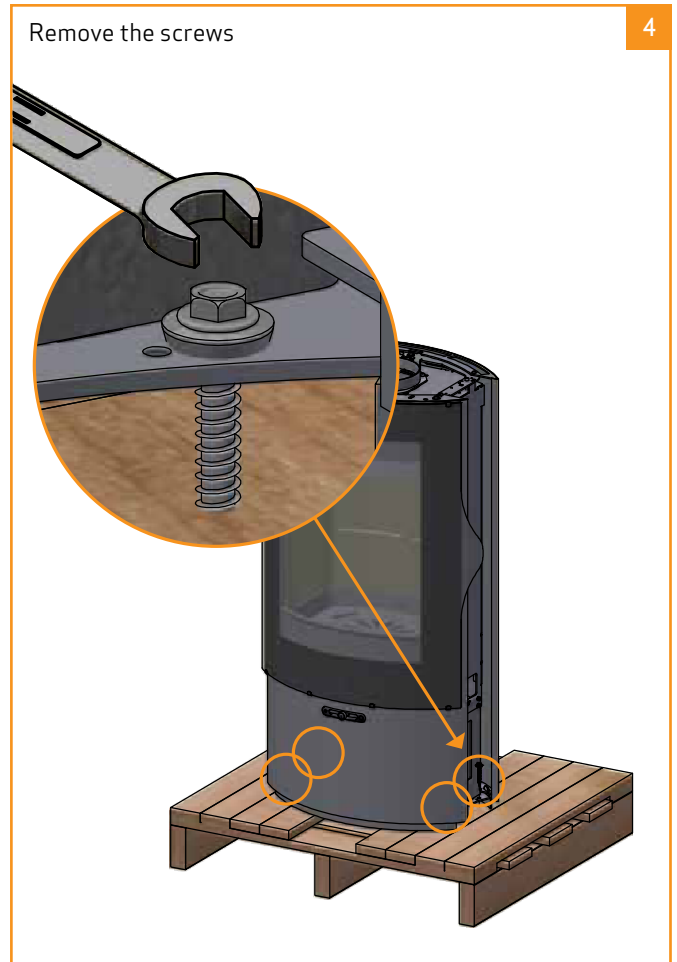

REMOVAL OF TRANSPORT PROTECTION

Note that the baffle plates are made of porous, ceramic material, and can break. Exercise care when working.

Lift the lower baffle plate, remove transport protection and the pin

1

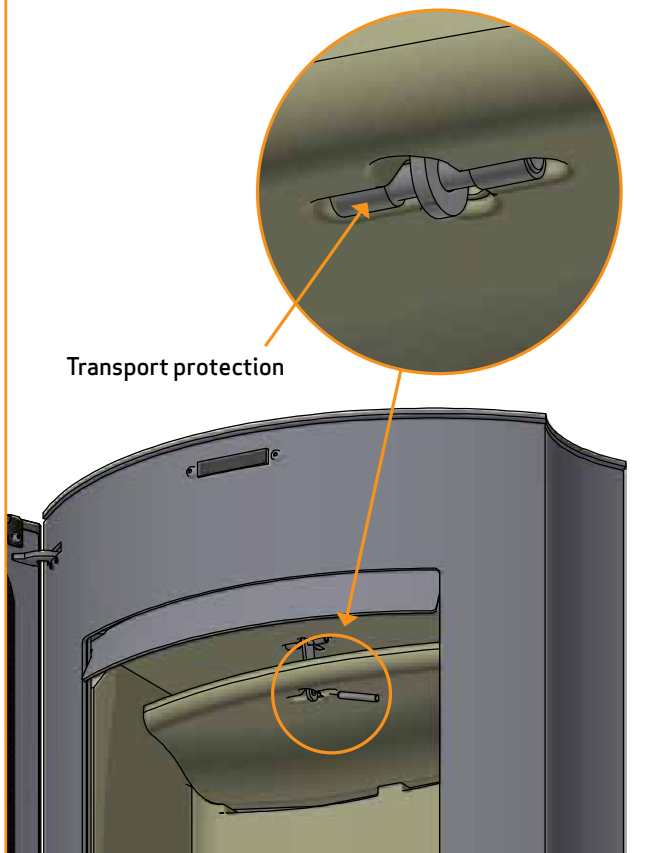

Lift the upper baffle plate and remove protection

3

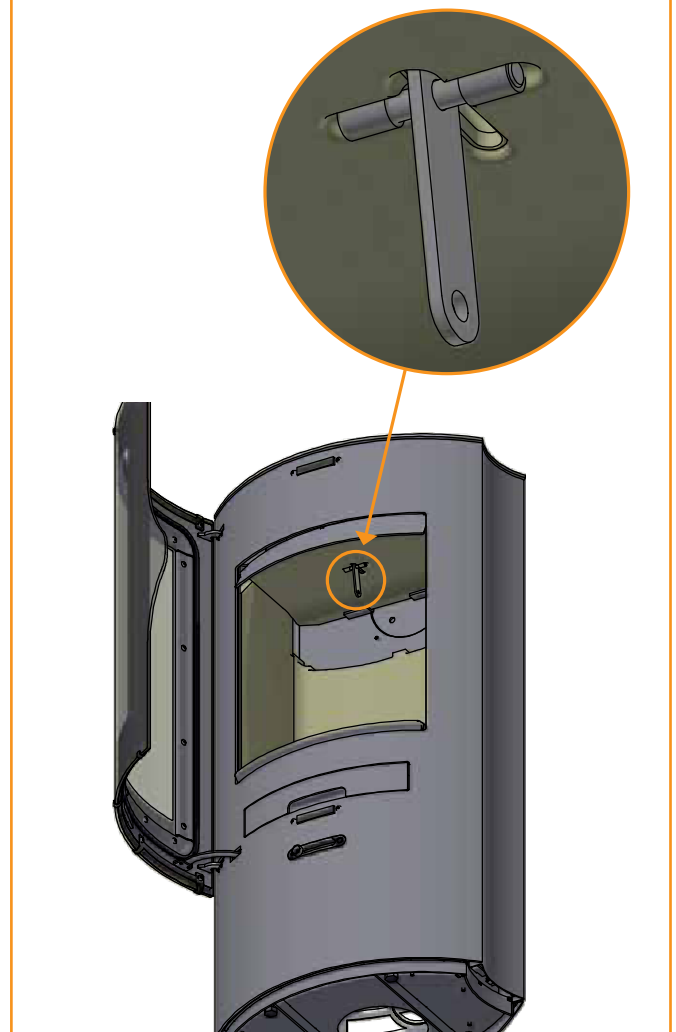

Lower the baffle plate out through the combustion chamber

2

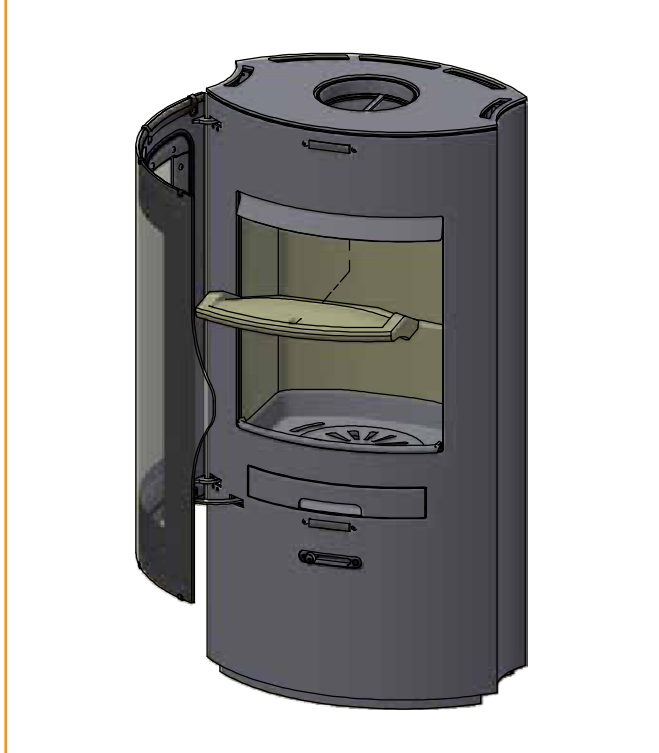

Mount again the upper baffle plate with the accompanying pin and the lower baffle plate is fitted afterwards

4

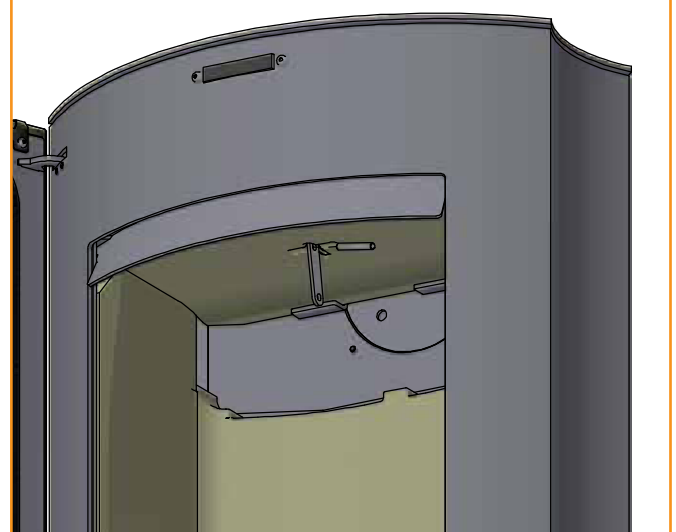

HEIGHT ADJUSTMENT OF STOVE

The stove has four adjustment screws under the stove. Use the adjustment screws to get the stove to stand straight and level.

NOTICE: It is very important that the stove is level to allow an optimal function of the door. Please note that once mounted the stove can no longer be adjusted!



DOOR (SELF-CLOSING)

The door is delivered with self-closing function (Bauart 1).

NOTE: After leveling the stove, always check that the door closes by itself. Open the door 50 mm from the stove. If it does not close by itself, carefully adjust the self-closing by turning the long screw (inside the spring) counter-clockwise using an Allen key (5 mm) and at the same time tightening the pointed screw at the bottom with an Allen key (2.5 mm).

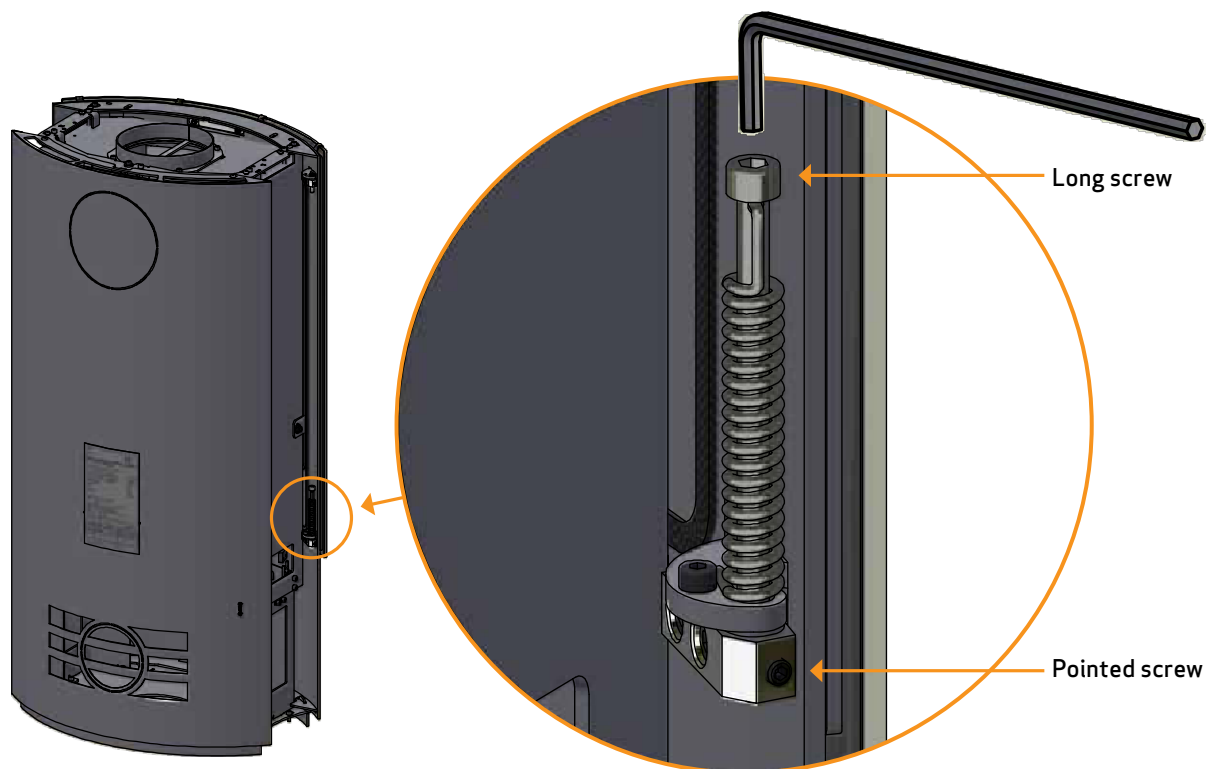

FITTING THE SIDE PLATES

The stove is delivered without side plates fitted.

NOTE! There is a difference between the side plates, so look for the marking L for LEFT and R for RIGHT

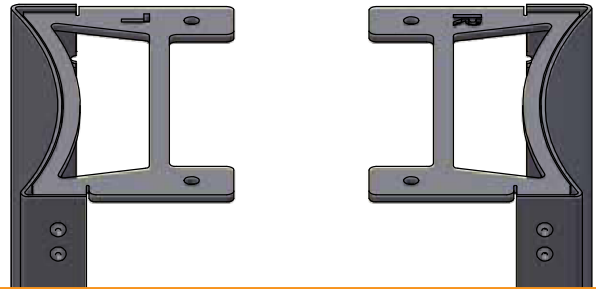

1. Fit the side plate bottom with 2 screws

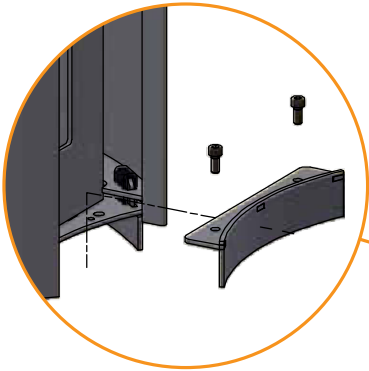

2. Then fit the side plates with 2 screws at the top

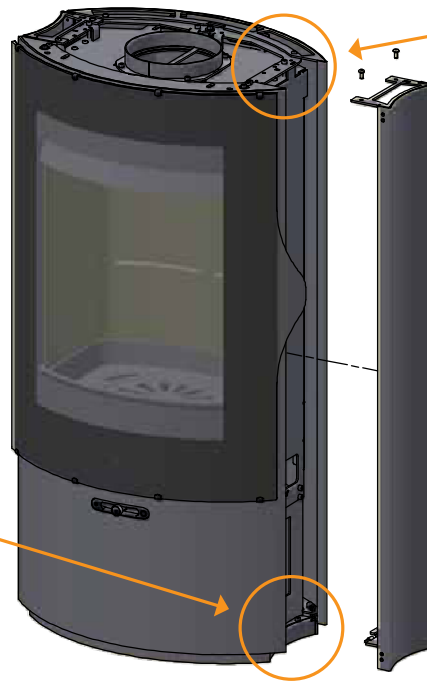
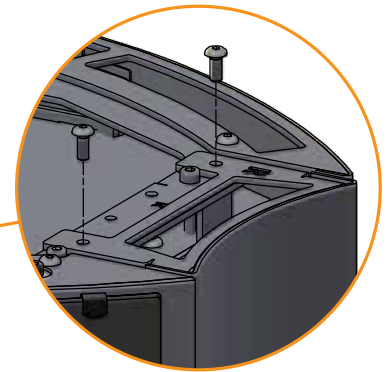

FITTING THE FLUE CONNECTION PIECE IN THE REAR OUTLET (ACCESSORY)

The stove is prepared from the factory for top outlet for inside flue pipe.

1

Before installing the flue pipe, the inner rear wall must be mounted with a flue gas deflector plate.

Before installing the flue gas deflector plate, the baffle plates must be removed. (See section "Removal of baffle plates and combustion lining")

Flue gas deflector plate

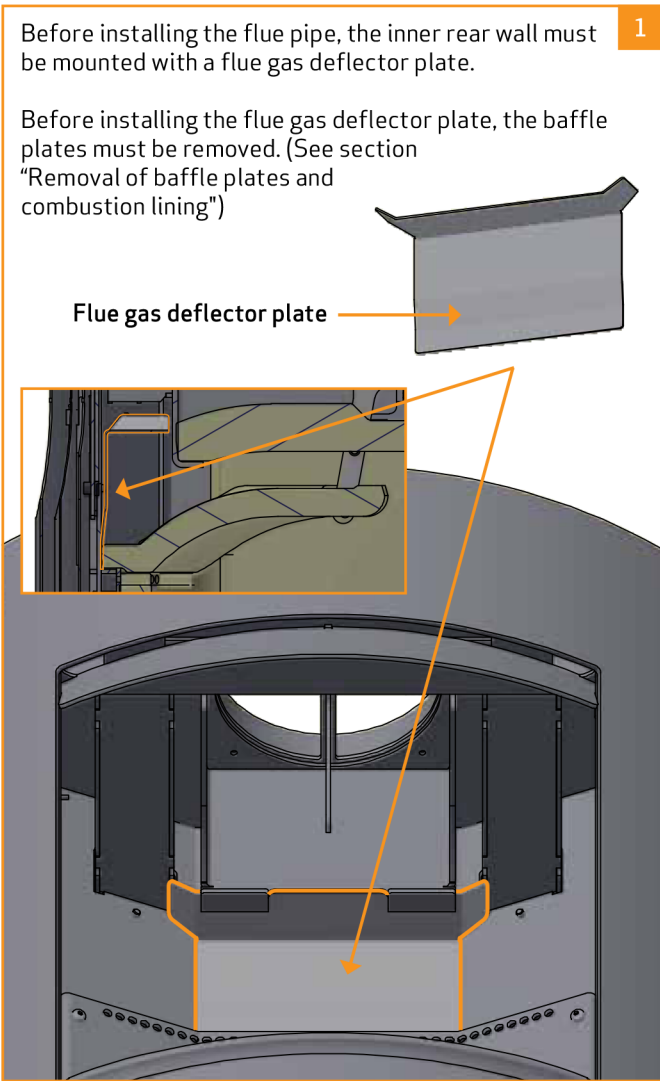

3

Remove the back plate and heat shields

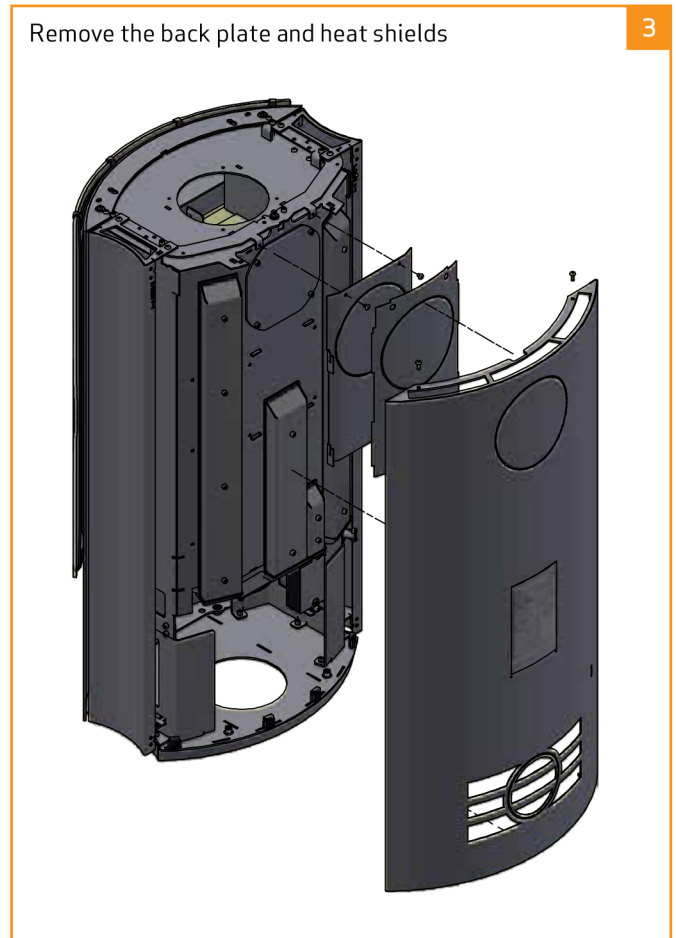

2

Unscrew the stove's connecting piece and remove it



4

Using cutting pliers, cut off the cover plate from the rear plate and at its securing points

Heat shield

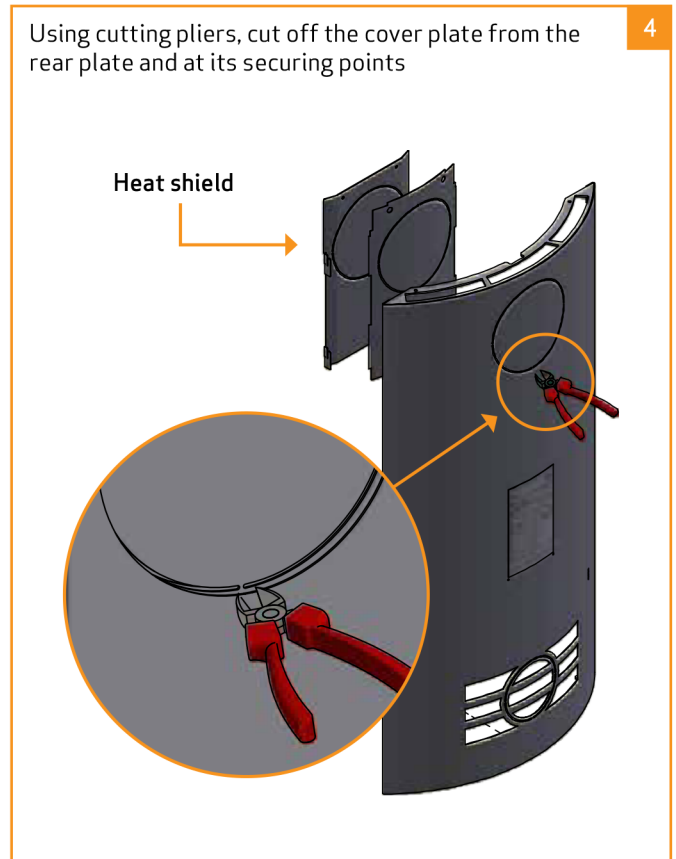

Continued on next page

FITTING THE FLUE CONNECTION PIECE IN THE REAR OUTLET (ACCESSORY)

Remove the cover.

This is to be used later as a seal and cover at the top of the smoke outlet

5

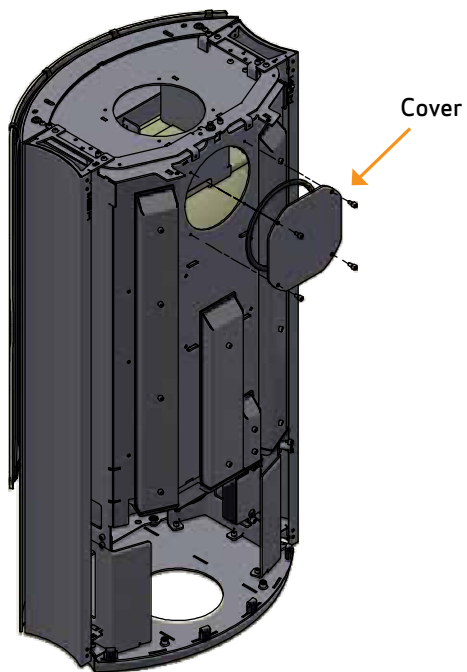

Remount the back plate and heat shields

8

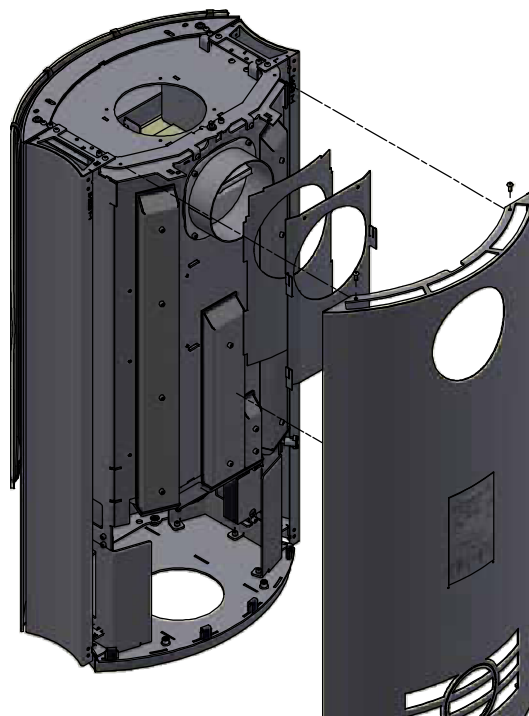

Mount the ceramic gasket on the connecting piece

6

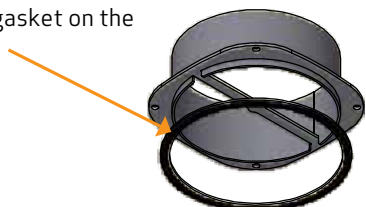

Fit the connecting piece with the four screws

7

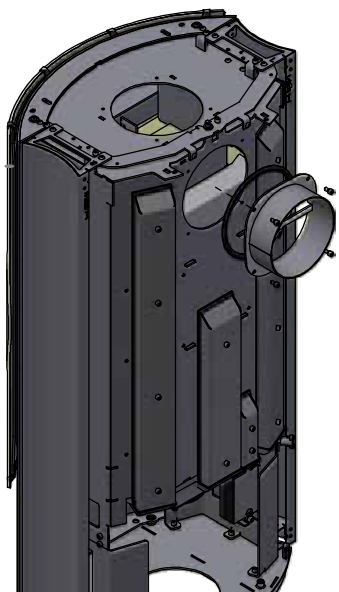

Fit the cover and tighten it.

9

Place the top plate

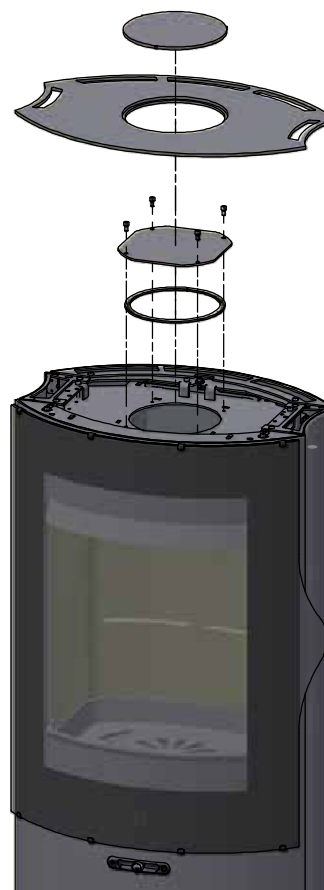

MOUNTING OF WALL-HUNG MODEL

Installation must be planned and executed in accordance with national and local building regulations.

The stove must only be fitted to a non-flammable wall. There must be no form of flammable component in the wall.

To ensure correct installation we recommend that a building expert and a local chimney sweep be commissioned to plan and outline the installation with a view to subsequent approval.

For wall installation we recommend using the wall brackets supplied.

If a chimney is installed on top of a wall-hung model, the chimney must be fully self-supporting. It must not rest on the wood-burning stove. There must be a distance of at least 6 mm between the first section and the flange on the flue collar. Please consult a specialist.

Scan A/S disclaims all liability for the installation of wall-hung wood-burning stoves.

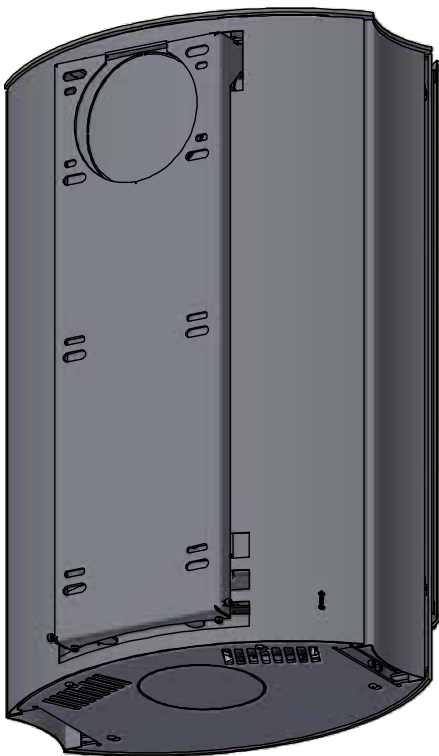

In order to mount the wall fitting to a chimney made of Leca-blocks you need 6-8 pcs. FBS 8x70/5 US Leca screws.

The test report can be required at Scan A/S



1 Draw a vertical line on the wall (you can use a spirit level). Use this line for the mounting of the wall fitting

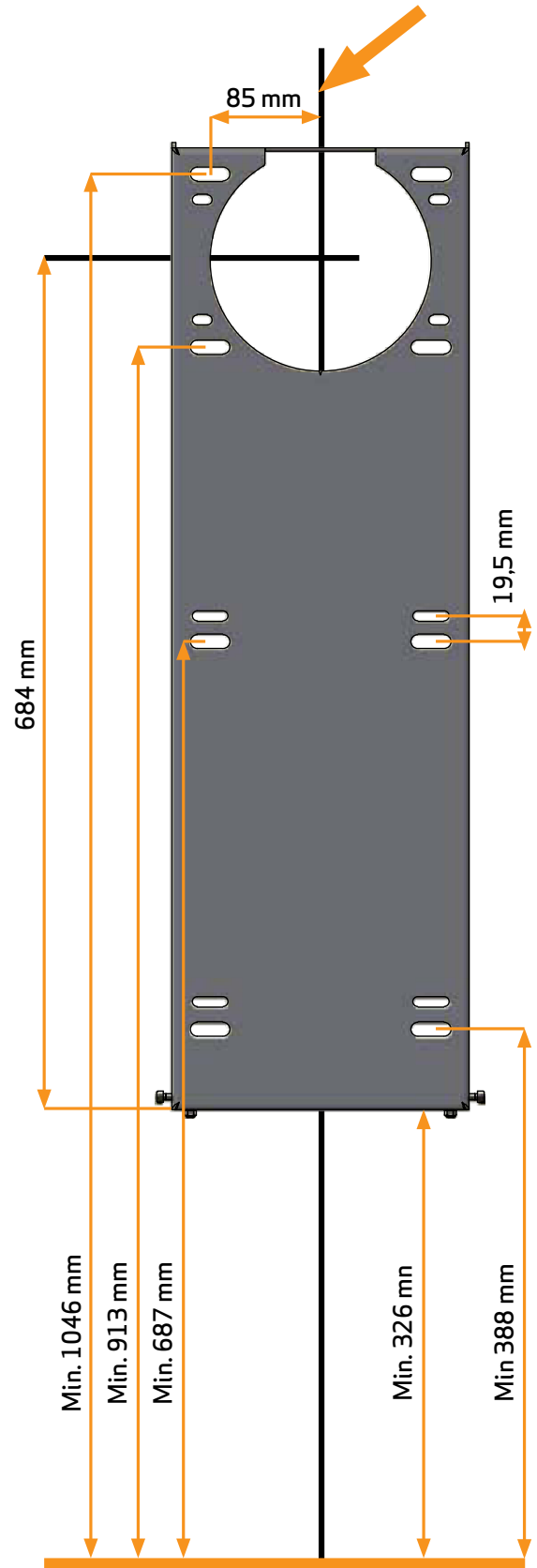

Continued on next page

MOUNTING OF WALL-HUNG MODEL

Remove the wall bracket by unscrewing the 2 screws that secure the wall bracket to the stove. If necessary, hold on to the wall bracket during removal from the stove.

2

NOTE: The stove may break if the wall bracket is tilted out of the stove before removing the screws, so be extremely careful!

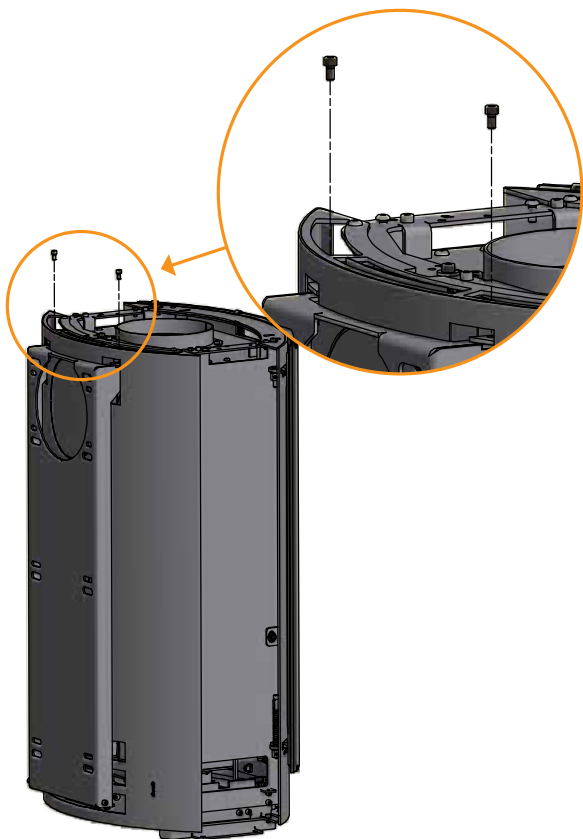

Now hook the stove onto the wall fitting on the wall. Then fit the 2 screws.

4



Measure from the vertical line.

3

Drill the necessary holes and mount the wall bracket with the screws.

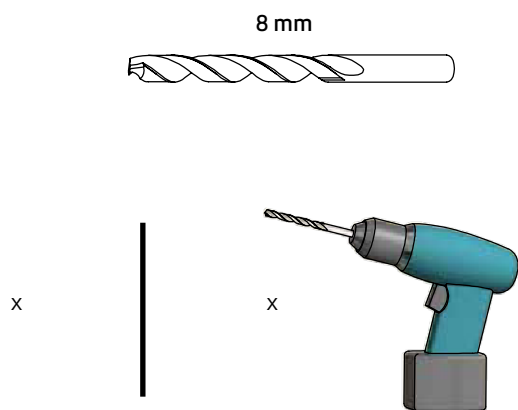

Adjust the stove so that the doors have the correct slope.

5

Spirit level

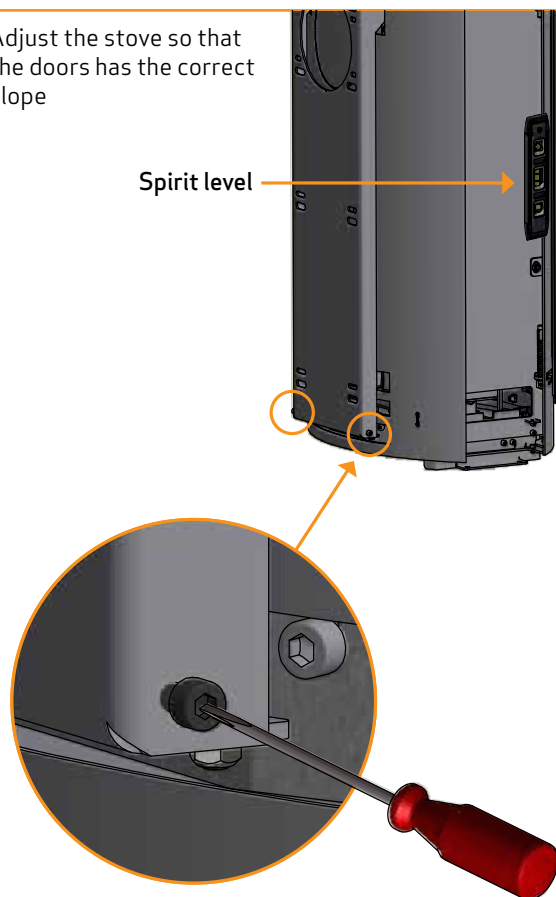

Continued on next page

MOUNTING OF WALL-HUNG MODEL

Remove the pallet bracket by unscrewing the 2 screws that secure the pallet bracket to the stove

6

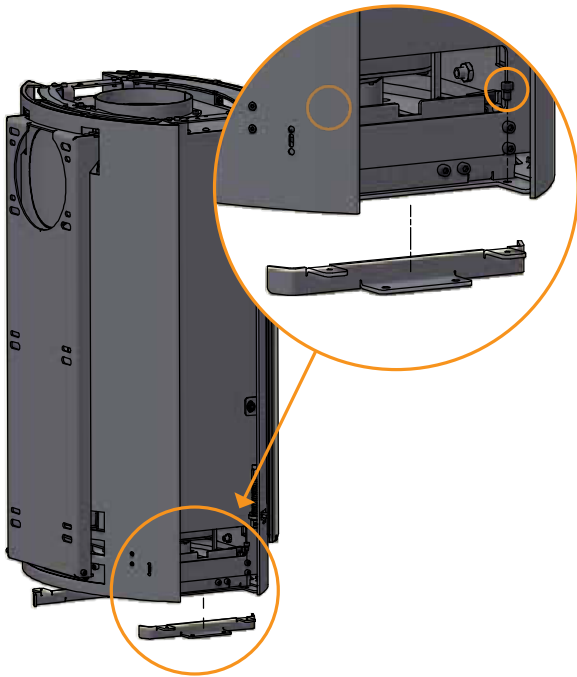

If you want a rear outlet, see page 18-19 in this manual

8

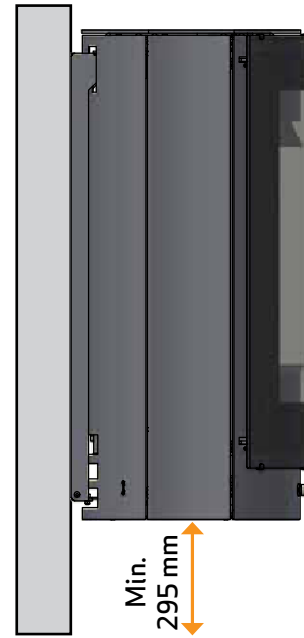

Floor distance

Fit the side plates with 2 screws at the top

7

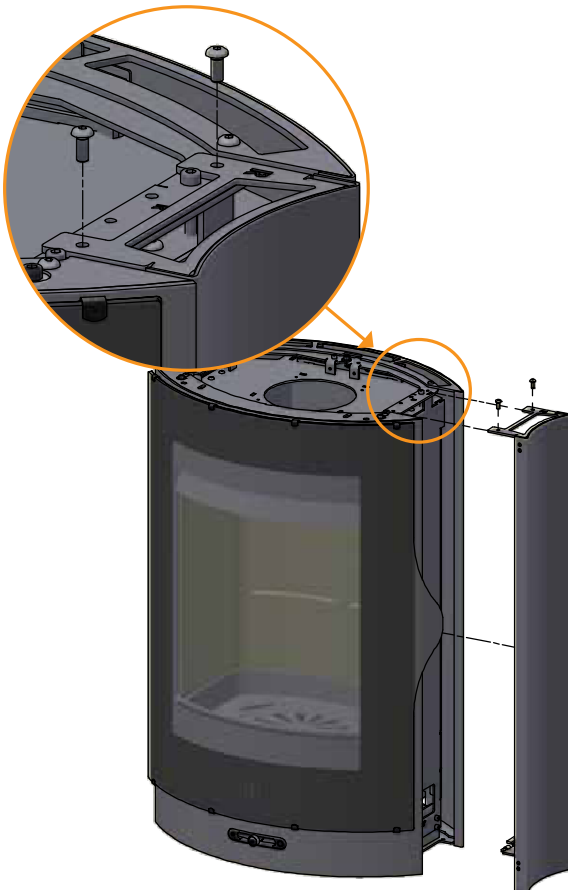

LOAD-BEARING FOUNDATION

All items in our product range come under the category of lightweight fireplaces and stoves and do not normally require any reinforcement of the beam structure. They can be positioned on ordinary beams/floor.

You should of course make sure that the foundation on which the stove is positioned can indeed support the weight of the stove and, where applicable, a steel chimney, if you have opted for this solution. In case of doubt about the carrying capacity of the floor, please consult a building expert.

FLOOR PLATE (ACCESSORY)

If you are placing the stove on a flammable floor, you must comply with the national and local regulations on the size of any non-flammable subsurface required to cover the floor around the stove.

Your local Scan dealer can advise you on regulations concerning protection of flammable materials in the vicinity of your stove.

The floor plate's function is to protect the floor and flammable material against any sparks that may occur. A floor plate can be made of steel or glass, but the stove can also be erected on clinker concrete, natural stone or similar materials.

This Scan wood-burning stove has an integrated floor plate at the bottom and can thus be erected directly on flammable material without the need for further protection underneath the stove.



Small shaped floor plate in glass



Large shaped floor plate in glass



INSTRUCTIONS FOR USE

Baffle plates

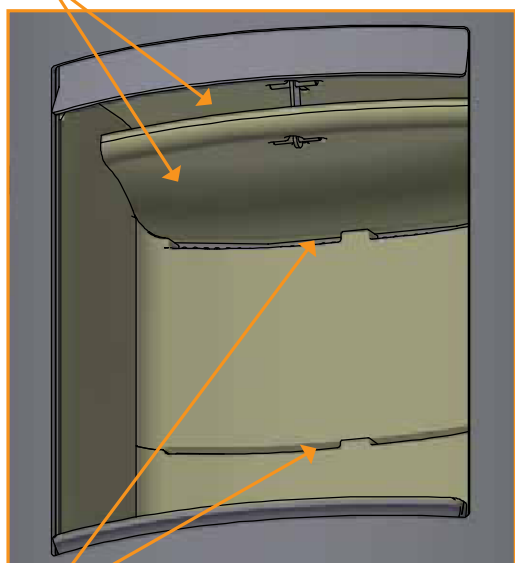

Tertiary holes

CB-TECHNOLOGY (CLEAN BURN)

The stove is equipped with CB technology. In order to ensure optimal combustion of gases released during the combustion process, air passes through a specially developed system of channels. The heated air is conducted into the combustion chamber through the holes in the rear lining of the combustion chamber and at the baffle plates. This airflow is controlled by the rate of combustion and cannot therefore be regulated.

NOTE: The wood must never be placed higher than the lower holes at the rear of the burn chamber (This does not apply at a cold start).

BAFFLE PLATES

The baffle plates are located in the upper part of the combustion chamber. The plates hold back smoke, making sure it stays inside the combustion chamber for a longer time before escaping through the chimney. This reduces the flue gas temperature as the gases have more time to dissipate heat to the stove.

The baffle plates must be removed for sweeping; see "Maintenance". Note that the baffle plates are made of porous, ceramic material, and is liable to break easily. You should therefore handle them with care.

The baffle plates are subject to wear and tear and not covered by the warranty.

MANUAL AIR CONTROL

With low draft in the chimney, the air regulation can be set to 100 % when lighting.

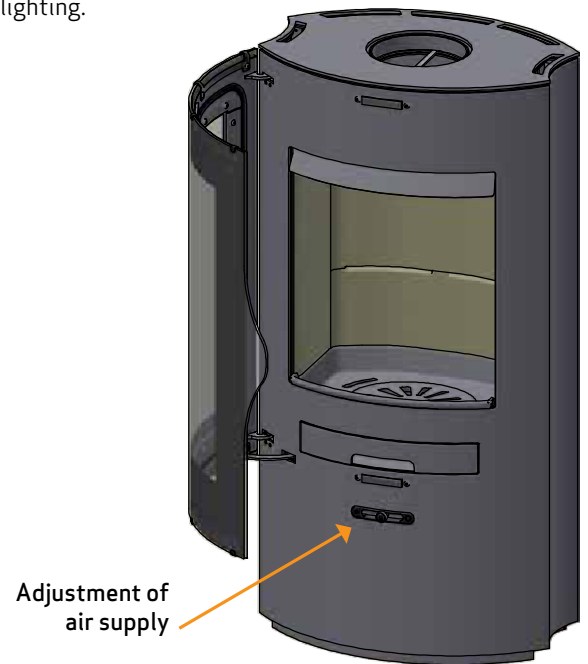
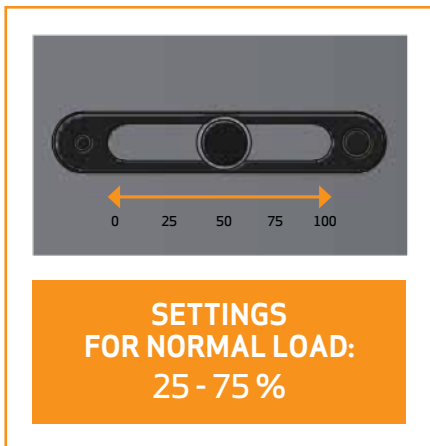

ASH CONTAINER

Open the door of the stove to access the ash container under the combustion chamber.

- The ash container must always be closed during operation
- The ash container must not become too full and must therefore be emptied at regular intervals
- The ash container can be warm. Wear a glove when handling the stove
- Never empty ashes into a flammable container. Ashes can contain glowing embers long after you finish operating the stove

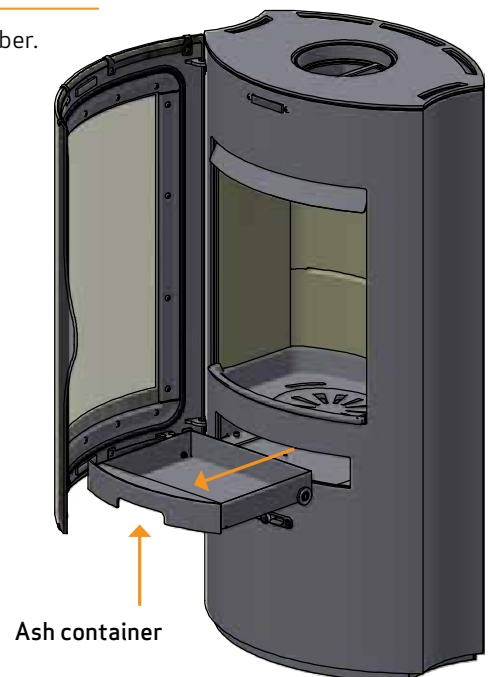

INSTRUCTIONS FOR HEATING

FIRST HEATING AND PAINT HARDENING

Perform the first heating using a small amount of wood, approximately half of the normal fuel load, and use smaller pieces.

Open both the primary and secondary air inlets fully. A slow and gradual heating process helps prevent paint damage and material deformation.

Once the initial fuel has burned down to glowing embers, you can begin the paint-hardening process.

Load the allowed fuel quantity, again using smaller logs and pieces.

After this load has burned out, repeat the process 2 to 3 times with the maximum allowed fuel dose, with the primary and secondary air inlets fully open.

During paint hardening, the product may emit a non-toxic odor. Ensure the room is well ventilated.

Allow the fire to burn with strong draft until no odor remains.

ENVIRONMENTALLY-FRIENDLY FIRING

Avoid turning down your woodburning-stove to the point where no flames are visible from the wood, as this leads to poor combustion and low efficiency. The gases released from the wood will not be burnt off due to the low temperature in the combustion chamber. Some of the gases will condense in the stove and flue system as soot, and this could lead to your chimney catching fire at a later point. The residual smoke which exits the chimney will pollute the surrounding area and cause an unpleasant smell.

LIGHTING

We recommend the use of fire lighters, or similar products. Using fire lighters helps light the wood more quickly and keeps the combustion process clean.

NOTE: Never use liquid lighting fuels!

The combustion chamber lining may turn black when the fire is lit. It will burn clear again the next time wood is added.

NOTE!
See our video
about correct firing



"TOP DOWN" LIGHTING

"Top down" lighting is a more environmentally friendly way of lighting the fire and helps to keep the glass area as clean as possible.

Do as follows for a correct "top down" lighting:

- 4 pieces of wood approx. 20-25 cm long with a weight of approx. 0,3-0,5 kg per piece
- 10-12 thin pieces of firewood of about 20 cm in length, with a total weight of approx. 0,6-0,8 kg.
- 3 fire lighters in bag or block form

- 1 Place the pieces of wood, firewood and fire lighters in the combustion chamber as shown below
- 2 Set the air regulation to maximum for 15 minutes (See "Instructions for use")
- 3 When the large pieces of wood have caught fire, you can adjust the air regulation to the desired level

NOTE: The wood must never be placed higher than the lower tertiary holes at the rear of the burn chamber (This does not apply at a cold start).

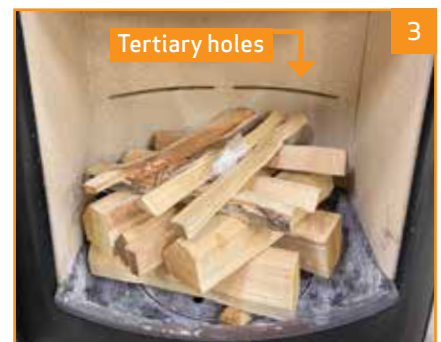

REFUELLING CRITERIA

It is important to obtain as high a temperature as possible in the combustion chamber. This results in best possible use of the stove and fuel, as well as achieving clean combustion. In this way you will avoid build-up of soot on the combustion chamber lining and glass pane. During operation, you should not see any smoke; just a movement in the air that indicates combustion is in progress.

- After completing the lighting phase, you should have a good layer of embers in the stove; you can then start operation of it properly
- Add 2 pieces of wood at a time: they should be about 0,6-0,8 kg in weight and about 20-25 cm long

NOTE: The wood must catch fire quickly. This is why we recommend setting the combustion air flow fully open. Operating the stove at too low a temperature and with too little the combustion air can lead to gases igniting, which can damage the stove.

- When adding wood, always open the glass door carefully to prevent smoke escaping. Keep the door closed during the whole combustion phase
- Never add wood, while the fire is burning nicely

At the EN 16510-test the stove was fired as shown on the picture:

At nominal heat output:

With 2 pieces of birch each 240 mm - 15-16 % wood humidity
- with a total weight of 1.35 kg.

Air regulation: 15 % open

Refuelling interval: 44 min

Amount of embers: 177 g

The criterion for the end of test cycle: 4,5-5,5 % CO₂



At part load heat output:

With 2 pieces of birch each 200 mm - 14 % wood humidity - with a total weight of 1.0 kg.

Air regulation: 20 % open

Setting to max is gradually turned down to 20%/13 mm when there are flames

Refuelling interval: 46 min

Amount of embers: 260 g

The criterion for the end of test cycle: 4,5-5,5 % CO₂



WARNING ABOUT OVER-FIRING

If the stove is continuously fired with larger amounts of wood than recommended and/or receives too much air, this can cause a heavy heat development liable to damage both stove and the surrounding walls. We therefore recommend that you always observe the max. recommended amount of fuel (See under "Technical Data").

USING THE STOVE IN VARIOUS WEATHER CONDITIONS

The way the wind affects the chimney can have a big impact on how your stove reacts under various wind loads; you may need to adjust the airflow to achieve good combustion. Fitting a damper in the flue pipe may also help, as it will allow you to regulate the draught under changing wind loads. The damper must not close more than 80% of the flue pipe.

Fog and mist can also have a big impact on chimney draught; you may need to use other settings for the combustion air to achieve good combustion.

FIRING IN THE SPRING OR AUTUMN

In the spring/autumn transition period, where there is less need for heating, we recommend you light the stove "top down" once, perhaps adding just two pieces of wood as above to ensure that the combustion chamber lining burns clean again.

THE FUNCTION OF THE CHIMNEY

The chimney is the wood-burning stove's motor; its performance determines how well your stove will work. The draught in the chimney creates negative pressure in the wood-burning stove. The negative pressure draws the smoke out of the stove and takes in air through the combustion air damper to fuel the combustion process. Combustion air is also used for the air wash system that keeps the window clear of soot.

The draught in the chimney is created by the difference in temperature inside and outside the chimney. The higher temperature difference, the better draught. This is why it is important that the chimney reaches operating temperature before you reduce the damper settings to restrict combustion in the stove (a brickwork chimney will take longer to reach operating temperature than a steel chimney). It is very important that the operating temperature is reached as quickly as possible on days when the draught in the chimney is poor due to unfavorable wind and weather conditions. You need to get a few flames going as quickly as possible. Chop the wood extra thin; use an extra fire lighter etc.

- After longer periods without use, you must check the chimney flue for blockages
- You can connect several units to the same chimney. You should however first check the local regulations in this respect

CHIMNEY FIRE

In the event of a chimney fire, keep the stove door and dampers on the stove closed. In an emergency, call the fire service.

- We recommend that you get a chimney sweep to check the chimney before using the stove again

GENERAL NOTES

PLEASE NOTE! Parts of the wood-burning stove, especially the outer surfaces, become hot during use. Due care should be exercised.

- Wear a glove when handling the stove
- Never empty ashes into a flammable container. Ashes can contain glowing embers long after you finish operating the stove
- Keep the combustion chamber closed except during ignition, refuelling and removal of residue material to prevent fume spillage
- Keep the air intake and output holes free from any accidental blockage while the stove is in use
- When the stove is not in use you can close the dampers to avoid a draught through the stove
- If the stove has not been used for some time, you should check the flue passageways for potential blockages before relighting
- We advise you strongly not to use the stove over night. The stove is not suited for this purpose

NOTE: Never place flammable material in the radiation zone of the stove!

HANDLING OF THE FUEL

SELECTING WOOD/FUEL

You can use any type of wood as fuel. However harder woods, such as beech or ash, are generally better for heating, as they burn more evenly and create less ash. Other woods, such as maple, birch and spruce, are excellent alternatives.

PREPARATION

The best fuel is obtained where the tree has been felled and the wood sawn and split before May 1st. Remember to cut the wood to match the size of the combustion chamber. We recommend a diameter of 6-10 cm. The length should be about 6 cm shorter than that of the combustion chamber to leave enough space for air to circulate. If the diameter of the wood is greater than the above, it should be split down its length. Wood that has been split dries faster.

STORING

You need to store the sawn and split wood in a dry place for 1-2 years before it will be dry enough to burn. Wood dries faster if you stack it in an airy place. Before using it, it is a good idea to store the wood for a few days at room temperature. Remember that wood absorbs moisture from the air during autumn and winter.

MOISTURE

To avoid problematic impact on the environment and to ensure optimum operating economy, the wood should be perfectly dry before it can be used as fuel. If you use wood that is too damp, most of the heat it produces will be used up in evaporating the water. The stove will accordingly not increase in temperature, nor emit heat to the room as a result. This is obviously poor economy, and it will cause soot build-up on the glass pane, in the stove and in the chimney. Operation using moist wood also pollutes the environment.

- Maximum wood moisture content should not exceed 20%. A moisture content of 15-18% will deliver best efficiency
- An easy way of checking wood moisture content is to knock the ends of the two pieces of wood together. If the wood is moist, the sound will be slightly muffled
- It is a good idea to take the wood into the house a day before it is to be used

USE OF THE FOLLOWING AS FUEL IS ILLEGAL

NOTE: It is absolutely prohibited to fire with painted, pressure impregnated or glued wood, or sea driftwood.

NOTE: Never use gasoline, gasoline-type lantern fuel, kerosene, charcoal lighter fluid, ethyl alcohol or similar liquids to start or "reignite" a fire in the stove. Keep all such liquids well away from the stove while it is in use.

NOTE: Nor should you ever burn chipboard, plastics, waste or treated paper. These contain substances that are hazardous to human health, to the environment, your stove, and your chimney.

In short - make sure you only use proper wood.

CALORIFIC VALUE OF THE WOOD

The various woods have different calorific values. In other words, for certain species of wood, you will need to use a greater quantity to achieve the same heating performance. This Instruction Manual assumes that you will be using beech, which has a very high calorific value and is also the easiest wood to get hold on. If you use oak or beech as fuel, you need to bear in mind that these wood types have a greater calorific value than for example birch. To avoid any risk of damage to the stove, you should therefore make sure to use less fuel in these cases.

Wood types	kg Drywood/m ³	Compared to beech
Hornbeam	640	110%
Beech/Oak	580	100%
Ash	570	98%
Maple	540	93%
Birch	510	88%
Pine	480	83%
Fir	390	67%
Poplar	380	65%

MAINTAINANCE

SWEEPING THE CHIMNEY AND CLEANING THE STOVE

Follow national and local regulations for sweeping the chimney. We recommend having the stove cleaned regularly by a chimney sweep.

Before cleaning the stove and sweeping the flue pipe and chimney, we recommend removing the baffle plates. (See section "Removal of baffle plates and combustion lining")

NOTE: All service and repair must be done, when the stove is cold.

CHECKING THE STOVE

Scan A/S recommends that you check your stove thoroughly after sweeping/cleaning. Check all visible surfaces for cracks. Check that all joints are tight and that the gaskets are correctly seated. Worn or deformed gaskets should be replaced.

SERVICING

We recommend that the stove is thoroughly serviced at least every two years by a qualified fitter. Remember only to use original spare parts.

The service should include the following:

- Lubricate hinges using copper grease
- Check the gaskets. Replace any that are broken or have turned hard
- Check the combustion chamber lining and the grate
- Check heat-insulating materials
- Check the locking device

COMBUSTION CHAMBER LINING

Slight cracks can appear in the combustion chamber lining due to moisture or sudden heating/cooling. These cracks have no influence on the output or lifetime of your stove. However, if the lining starts to crumble and fall out, you must replace it.

The combustion chamber lining is not covered by the warranty.

GASKETS

All wood-burning stoves have seals made of ceramic material fitted to the stove, the door and/or the glass. These seals are subject to wear and tear and must be replaced when necessary.

Gaskets are not covered by the warranty.

PAINTED SURFACES

Clean your wood-burning stove by wiping it down with a dry, lint-free cloth.

If the paint finish gets damaged, you can purchase repair paint in spray form from your Scan dealer. As slight differences in colour shade are possible, we recommend you spray a larger area to achieve a natural blend. For best results, apply repair spray when the stove is warm, but it should preferably not be scalding hot.

NOTE: Make sure to air the room thoroughly after applying spray paint.

REMOVAL OF BAFFLE PLATES AND COMBUSTION CHAMBER LINING

Be very careful when removing the baffle plates from the stove.

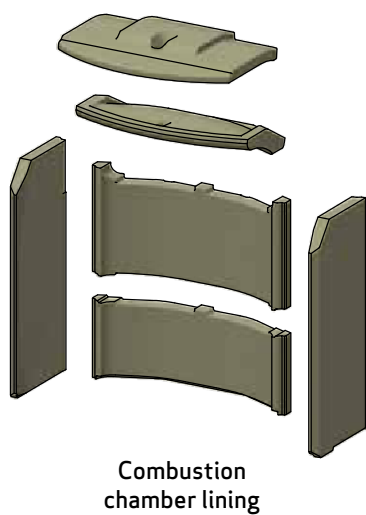
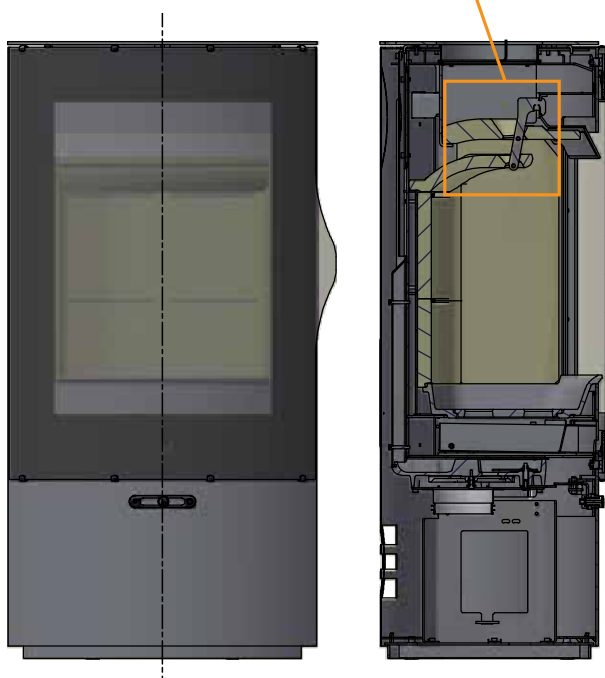
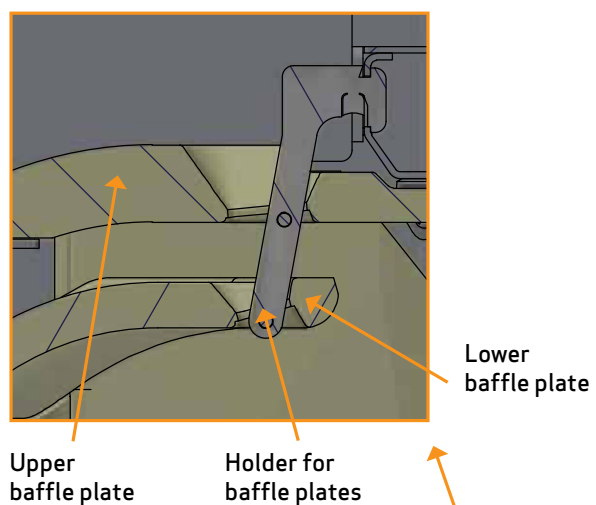

Lift the lower baffle plate and remove the pin

1

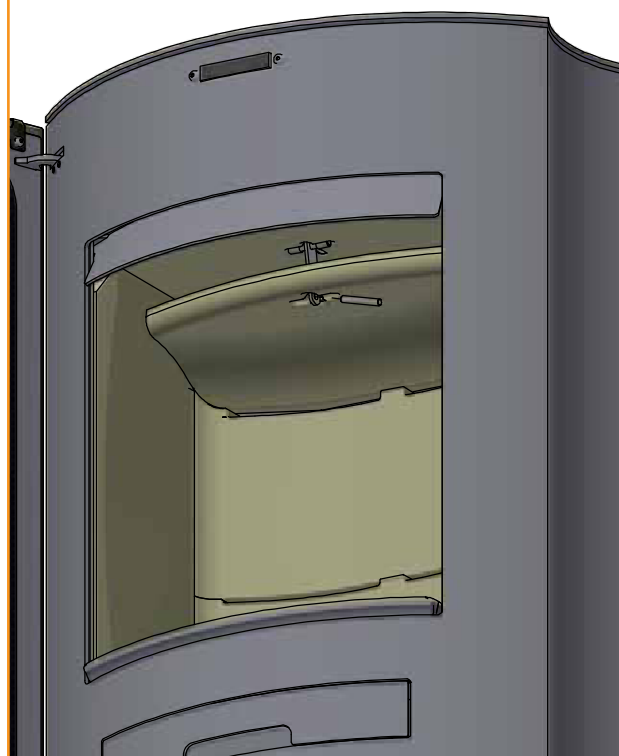

Lower the baffle plate out through the combustion chamber

2



Continued on next page

REMOVAL OF BAFFLE PLATES AND COMBUSTION CHAMBER LINING

Lift the upper baffle plate and remove the pin

3

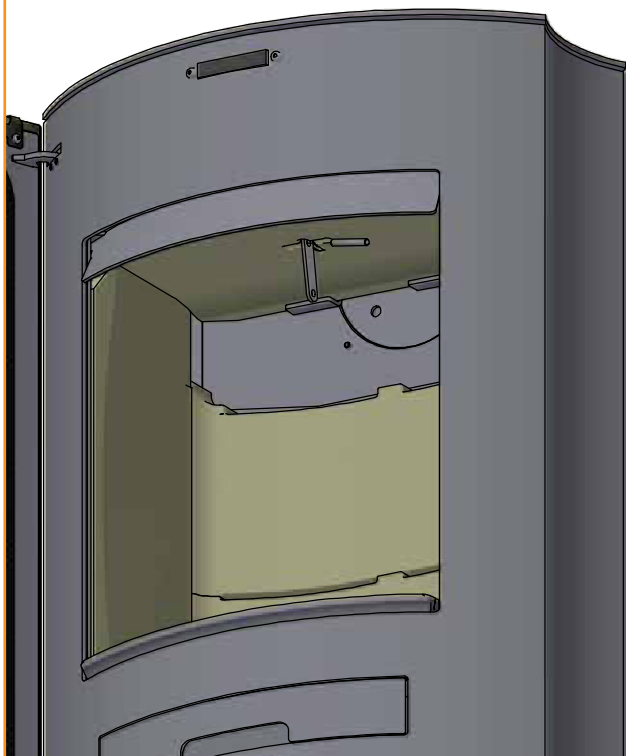

Pass the baffle plate edge-first and downwards out through the combustion chamber

4



Carefully lift the sides and rear plates of the combustion chamber lining out of the stove

5

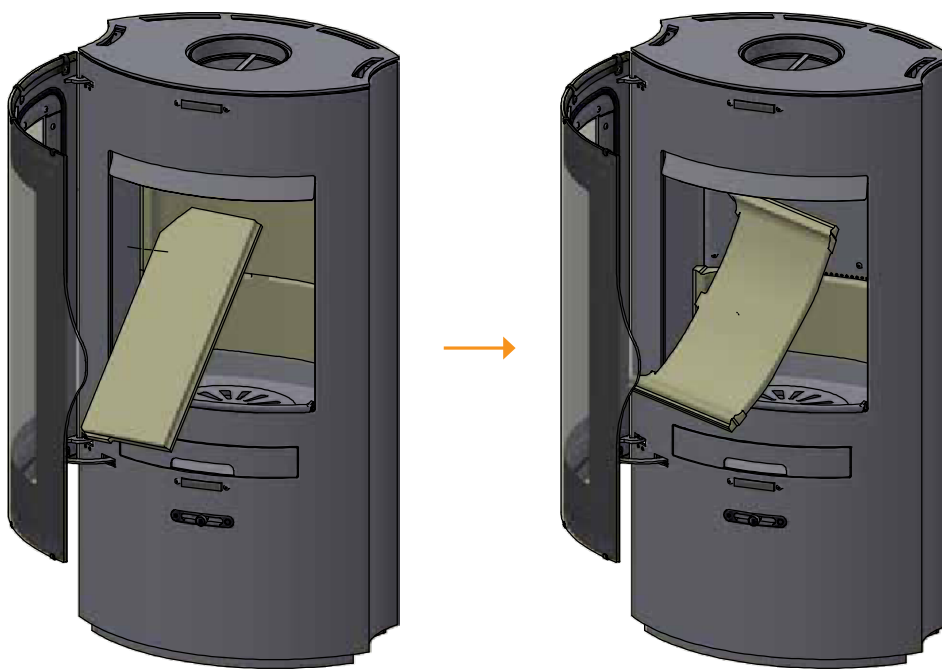

CLEANING THE GLASS

Our wood-burning stoves are designed to prevent serious soot build-up on the glass. The best way to achieve this is to make sure you have a good supply of combustion air. It is also very important that the wood is dry and the chimney correctly dimensioned.

Even if you operate the stove in accordance with our instructions, a slight film of soot may still accumulate on the glass. You can easily remove this film by wiping the glass down with a dry cloth and then with a cloth dampened with glass cleaner.

- Please note that the glass cleaner is not to get into contact with the gaskets, as this can discolour the glass permanently
- The glass cleaner must not come into contact with the painted surfaces, as these can be damaged

DISPOSAL OF STOVE PARTS

Steel/cast iron	Send for recycling
Glass	Dispose of as ceramic waste
Combustion chamber lining	Vermiculite is not recyclable. Dispose of as waste
Baffle plate	Vermiculite is not recyclable. Dispose of as waste
Gaskets	Dispose of as waste

TROUBLESHOOTING

SMOKE ESCAPING

- Damp wood
- Chimney is not properly dimensioned for the stove
- Is the chimney the right height for its surroundings?
- At rear outlet, check that the flue pipe does not obstruct the chimney draught
- Chimney not drawing properly
- Check if the smoke gas pipe/chimney are blocked
- Vacuum in room
- The door is opened before the embers have burned down sufficiently

WOOD BURNING TOO QUICKLY

- The air valves are set incorrectly
- Inferior firewood (waste wood, pallets etc.)
- The baffle plates is incorrectly mounted or missing
- Chimney too large

SOOT BUILD-UP ON GLASS

- Incorrect secondary airflow setting
- Damp wood
- Inferior firewood (waste wood, pallets etc.)
- Vacuum in room
- Excessive primary air
- Wood pieces too large on lighting
- Chimney not drawing sufficiently

WHITE SHADOW ON THE INSIDE OF THE GLASS

- Over-firing (See "Instructions for heating")
- Vacuum in the room
- Too much primary air

EXCESSIVE SOOT BUILD-UP IN CHIMNEY

- Poor burning (more air required)
- Damp wood

THE SURFACE OF THE STOVE IS TURNING GREY

- Overheating (see instructions for heating)

POOR HEATING PERFORMANCE OF STOVE

- Damp wood
- Inferior wood quality with low fuel value
- Not enough wood
- Baffle plates are not fitted correctly

SMELL AND SOUND OF THE STOVE

- The lacquer on the stove hardens when you use the stove for the first time; this can cause an odour. Open a window or a door for ventilation, and make sure the stove is heated up sufficiently to avoid odours later
- When heating up and cooling down, the stove may make some clicking noises. These are due to the huge temperature differences to which the material is exposed and do not indicate any product defects

WARRANTY

All wood-fired Scan products are made of high-quality materials and subject to strict quality controls before leaving the factory. We give a warranty of 5 years on manufacturing errors or defects.

You must quote your stove's product registration number when you contact us or your authorized Scan dealer with a warranty claim.

The warranty covers all parts which in the opinion of Scan A/S require repair or replacement due to manufacturing or construction error

The warranty applies to the original purchaser of the product only, and is not transferable (except on prior sale).

The warranty covers only damage caused by manufacturing or construction errors.

THE FOLLOWING PARTS ARE NOT COVERED BY THE WARRANTY

- Wear and tear parts, such as the combustion chamber liners, baffle plates, riddling grate, glass, and seals (except for defects which were present on delivery)
- Defects caused by external chemical and physical influences during transportation, storage and assembly, or at a later time.
- Soot build-up caused by poor chimney draught, damp wood, or improper use
- Costs of additional heating in connection with a repair
- Transport costs
- Costs for setting up, removing the wood stove

THIS WARRANTY IS VOID

- In case of incorrect installation (the installer is responsible for observing and complying with legal requirements and local bylaws, along with this Instructions manual for the wood-burning stove and accessories)
- In case of improper use, and/or use of prohibited fuels, non-original spares (see this instructions manual)
- If the product registration number of the stove has been removed or damaged
- In case of repairs that do not comply with our instructions or instructions by an authorized Scan dealer
- In case of any manipulation of the original state of this Scan product or its accessories. Any unauthorized modification of the stove may not be carried out
- This warranty is only valid in the country to which this Scan product was originally supplied

Always use original replacement parts, or parts recommended by the manufacturer.

Product registration number

Quote this number at all enquiries