

ALL
NEW



ISLAND

I - AP • II - BP

Operating & Installation Instructions

CONTENTS

QUICK GUIDE	4
OPERATING INSTRUCTIONS	5
FUEL	5
MULTI GRATE	5
RIDDLING	6
OPERATING TOOL HOLDER	6
LIGHTING	6
CONTROLLING THE FIRE	6
REFUELLING	7
ASH CLEARANCE	7
REDUCED BURNING	7
MAINTENANCE	7
THROAT PLATE AND FLUEWAY CLEANING	8
CHIMNEY SWEEPING	8
TROUBLE SHOOTING	9
CO ALARM	10
IF YOU NEED FURTHER HELP	10
INSTALLATION INSTRUCTIONS	11
UNPACKING THE STOVE	11
HEALTH AND SAFETY PRECAUTIONS	11
CO ALARMS	11
SPECIFICATION	11
CHIMNEY	12
HEARTH AND FIRE SURROUND	12
CONNECTIONS TO FLUES	12
SOOT DOORS	13
PRE LIGHTING CHECK	14
COMMISSIONING	14
CAA AND SMOKE CONTROL	14
DIMENSIONS ISLAND I - AP	15
DIMENSIONS ISLAND II - BP	16
PARTS LIST	17
ISLAND I - AP PARTS	17
ISLAND II - BP PARTS	18
CE CERTIFICATE	19

QUICK GUIDE

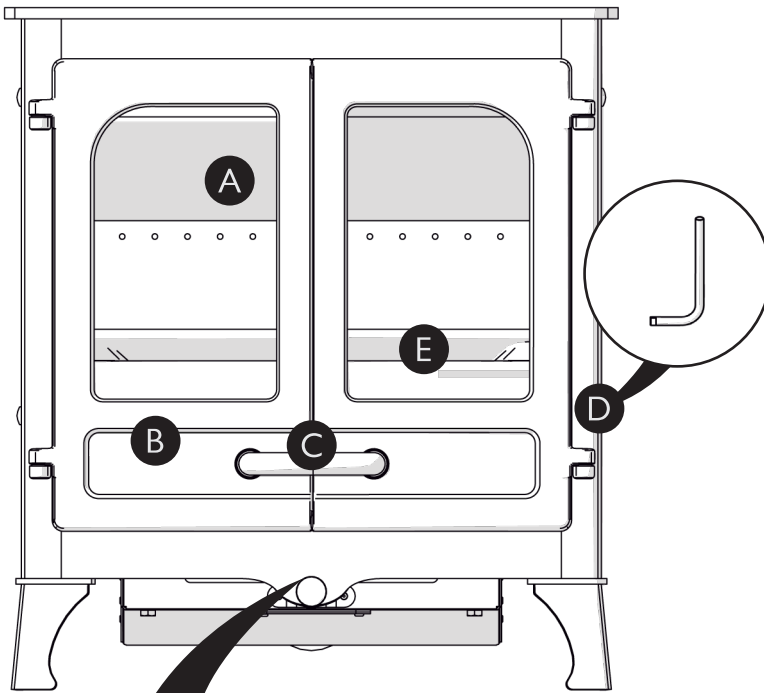

- A Throat plate**
Improves efficiency of stove by slowing down flue gases
- B Doors**
Keep closed when stove is in use
- C Door handle**
Turn clockwise to open
- D Riddler knob**
Use operating tool to riddle
- E Fuel retainer**
Ensure fuel does not protrude beyond retainer

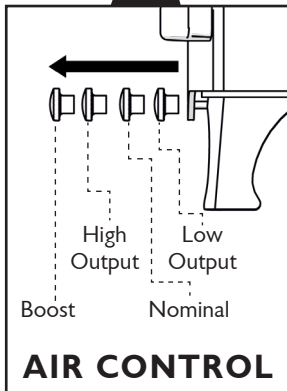

MAINTENANCE AND CLEANING

GLASS

Wipe with damp, lint free cloth. Any stubborn deposits on the glass may be removed with a proprietary stove glass cleaner or ceramic hob cleaner.

THROAT PLATE

Take down once a month and clean. Sweep sooty deposits into fire

CHIMNEY

Have chimney swept twice a year. Chimney can be swept through stove.

SERVICING

Stove should be serviced by a professional at least once a year.

LIGHTING AND CONTROLLING THE FIRE

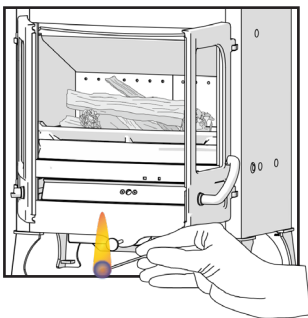

Add kindling and paper or firelighters. Keep air control fully out and close door.

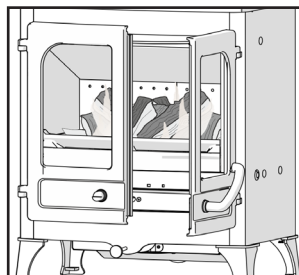

Once kindling is alight, add smaller logs. Keep air control fully out and close door.

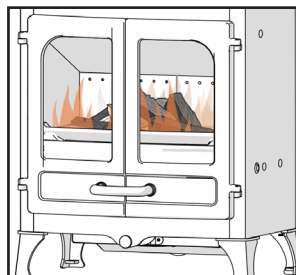

Add larger logs once fire is established. Air control can be reduced to minimum.

Suitable fuels for your

Charnwood:

Wood logs

Smokeless Fuel

Unsuitable fuels:

Petroleum coke

Liquid fuel

Household waste

Coal singles

Small nuts or coal dust

Wet or unseasoned wood



Congratulations on becoming the owner of a Charnwood Island Stove. Your stove has been approved in smoke control areas to burn wood logs if it is used in accordance with these instructions. It is very important that you read and understand these instructions before using the stove.

Before lighting the stove check with the installer that the work and checks described in the Installation Instructions have been carried out correctly and that the chimney has been swept, is sound and free from any obstructions. The stove is not suitable for use in a shared flue system.

Remember that the stove will be hot and that it is made from hard materials – ensure that you have good balance before operating the fire. Always use the provided operating tool and gloves.

Do not use an aerosol spray on or near the stove when it is alight. There is a risk of explosion or flash ignition of the spray.

When using the stove in situations where children, aged and/or infirm persons are present a fireguard must be used to prevent accidental contact with the stove. The fireguard should be manufactured in accordance with BS 8423:2002.

The stove is suitable for intermittent operation.

FUEL

Please pay careful attention to the special points made with each type of fuel as they will help you to get the best from your stove. It must be remembered that only authorised fuels and wood logs may be burnt in smoke control areas on this stove. If you are not sure whether you are in a smoke control area, please check with your Local Authority.

At first you may find it helpful to try several fuels to find the most suitable. If you are unable to obtain the fuel you want, ask your supplier, or an approved fuel distributor, to suggest an alternative.

Authorised Mineral Fuels

Authorised mineral fuels may be burned in smoke control areas on this appliance. Your local fuel supplier or stove shop will be able to advise you which fuels are available locally. A list of authorised fuels can be found at:

<https://smokecontrol.defra.gov.uk/fuels.php>

Take care to only burn good quality fuels in order to obtain the

greatest efficiency and to maintain the life of the appliance.

Wood logs

Only dry well seasoned wood should be burnt on this appliance as burning wet unseasoned wood will give rise to heavy tar deposits in the stove, on the glass and within the chimney. For the same reason hard woods (such as Ash, Beech and Oak) are better than soft woods (such as Pine and Spruce). Burning wet unseasoned wood will also result in considerably reduced outputs. The wood should be cut and split and then left to season in a well ventilated dry place for at least one year but preferably two years before use. Approximate suitable log sizes are:

Island I - AP : 400mm(15in) long and 75mm (3in) diameter

Island II - BP : 440mm(15in) long and 75mm (3in) diameter

Log moisture content of less than 20% is recommended.

PETROLEUM COKE IS NOT SUITABLE FOR USE ON THIS APPLIANCE. ITS USE WILL INVALIDATE THE GUARANTEE.

This stove is not designed to burn household waste.

MULTI GRATE

Your Charnwood Island is fitted with a multi grate to enable wood or smokeless fuel to be burned and ash to be cleared. The grate has two positions:

1) In the solid fuel position the grate bars are vertical with gaps in between allowing the primary combustion air to come up through the grate and through the fuel bed.

2) In the wood position the grate bars are horizontal, allowing the combustion air to come round the sides of the grate and over the top of it. When in the closed position ash is able to build up on the grate as is necessary for effective wood burning.

Movement of the grate from one position to the other is effected using the operation tool supplied as shown in Fig.1.

The grate is put into the solid fuel position by turning the operation tool anticlockwise and pulling out the fuel selection slider shown in Fig.1. The grate is put into the wood position by turning the operation tool clockwise. To riddle the appliance the tool should be moved between the clockwise and anticlockwise positions several

OPERATING INSTRUCTIONS



times. When burning wood the ash should be allowed to build up and riddling should only be carried out once or twice a week.

Fig.1 Operating the multi grate

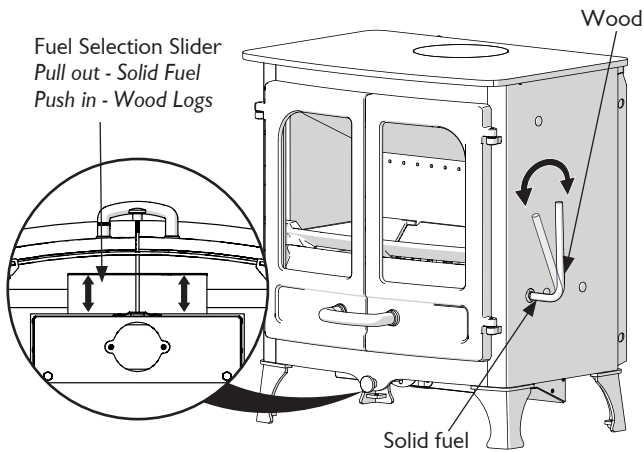

RIDDLING

When burning wood, ash should be allowed to build up and only riddled when the ash begins to cover the rear fireplate. The fire should be riddled with the door shut (see Fig.2). Place the operating tool onto the riddling lever and rotate between the open and closed positions several times. Too much riddling can result in emptying unburnt fuel into the ashpan and should therefore be avoided. After riddling, the grate should be put back into the closed position for burning wood.

Fig.2 Riddling tool

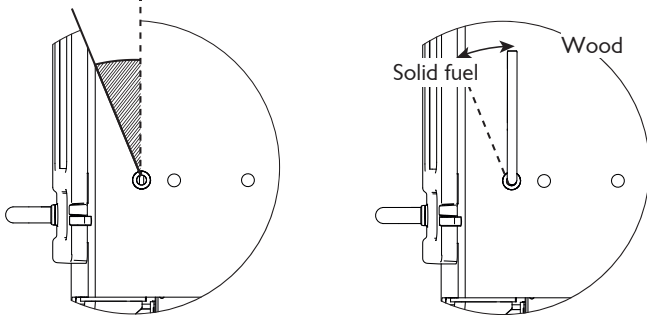

OPERATING TOOL HOLDER

When not in use the operating tool can be stored on the shelf underneath the stove.

LIGHTING

On initial lighting, the stove may smoke and give off an odour as the

silicon paint with which the firebox is painted reacts to the heat. This is normal and will cease after a short time, but meanwhile the room should be kept well ventilated.

At first only light a small fire and burn it slowly for two hours to allow any residual moisture in the chimney to evaporate.

Light the stove using dry kindling wood and paper or fire lighters. Put the paper, or fire lighters, and kindling in the firebox and cover with a few small dry logs. Open the air control fully (see Fig. 3). Light the paper or fire lighters. The door may be left cracked open for a few minutes to assist the combustion and heat up the firebox more quickly. When the kindling wood is well alight add a few more small logs, close the door but leave the air control fully open. When the flames are established around these logs, load the stove with the required fuel load. Maintain the air control at maximum at this stage. Once the fire is up to temperature the airwash system will begin to work, so allow the fire to become hot before adjusting the air control to the required setting. During the lighting period, do not leave the stove unattended. Do not leave the door open except as directed above to avoid excessive smoke.

When relighting the stove, leave the ash on the base if burning wood, unless it is becoming too deep, in which case some of it may be removed.

CONTROLLING THE FIRE

The rate of burning and hence the output is controlled by the air control (see Fig.3).

Fig. 3 Stove controls

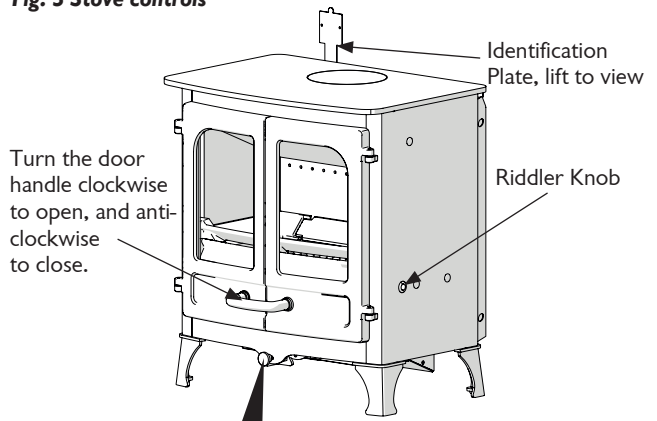

AIR CONTROL

Pull out to open, push in to close.

1. Low Output
2. Nominal
3. High Output
4. Boost



Open the air control fully (boost position) when lighting or when rapid burning is required. It should not be left fully open for long periods as this can cause over-firing or excessive smoke production. For high output move the air control to the 'click position' or for low burning to the fully closed position.

When the fire is burning normally the air control gives enough airwash to keep the glass clean. However, it will not always be possible to keep the glass clean with the air control fully closed. For correct firing we recommend the use of a stove pipe thermometer which may be purchased from your supplier or from Charnwood.

The Charnwood Island I - AP and Island II - BP is fitted with an air control stop for use in a smoke control area. This stops the stove from burning too slowly.

REFUELLING

Keep the firebox well filled but do not allow fuel to spill over the top of the fuel retainer.

Logs should be evenly distributed, filling the firebed to give the most pleasing flame pattern. The air control must be fully opened after refuelling until the flames are established above the fire. It is best to refuel on to a hot bed of embers. If at this point the fire starts to die, the door must be cracked open until the fire is revived. If the fire has started to die down before refuelling, then more kindling wood must be added, the air control opened fully and the door cracked open to re-establish the firebed before adding larger logs (see suitable log sizes in Fuel section). This will avoid excessive smoke emission.

Care should be taken, especially when burning wood, that fuel does not project over the fuel retainer or damage to the glass may be caused when the door is closed. It can also cause the glass to blacken up. Maximum filling height is such that logs cannot fall from the fire when the door is opened.

In smoke controlled areas do not fill the stove above the level of the air holes in the back bricks, as overloading can cause excess smoke.

Do not operate with the door left open except as directed by the instructions as this can cause excessive smoke.

ASH CLEARANCE

For optimum wood burning, it is important to leave a layer of ash around 1cm thick on the base of the stove. Before removing ash ensure that it has cooled down,

The ashpan is handled using the operation tool and gloves provided. Ensure that the tool is fully engaged before lifting (See Fig.4). When carrying the ashpan, it should be kept horizontal and supported by the carrying handle to prevent it falling off the tool. Please avoid emptying hot ash into plastic liners or bins.

The Ashpan should be emptied regularly before it becomes too full. Never allow the ash to accumulate in the ashpan so that it comes in contact with the underside of the grate as this will seriously damage the grate bars.

To make ash removal easier there are ash carriers available. These may be purchased from your supplier or, in case of difficulty, from Charnwood.

Fig.4 Ashpan

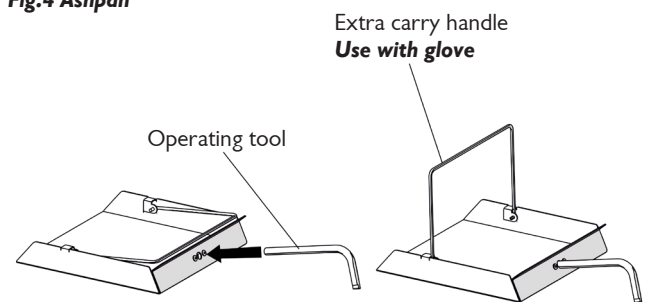

REDUCED BURNING

For reduced burning the fire door must be closed.

When burning wood in areas that are not smoke controlled, load some large logs on the fire and allow to burn for half an hour before closing the air control (this will help to reduce tar deposits in the chimney). Some experimentation may be necessary to find the setting most suitable for the type of fuel being used and the draw on the chimney.

MAINTENANCE

Cleaning

The stove is finished with a high temperature paint which will withstand the temperatures encountered in normal use. This may be cleaned with a damp lint-free cloth when the stove is cold. Should re-painting become necessary, high temperature paints are available from your supplier or from stove shops.



Cleaning the Glass

Most deposits on the glass may be burnt off simply by running the fire at a fast rate for a few minutes. If it becomes necessary to clean the glass then open the door and allow it to cool. Clean the glass using a damp cloth and then wiping over with a dry cloth. Any stubborn deposits on the glass may be removed with a proprietary stove glass cleaner or ceramic hob cleaner. Do not use abrasive cleaners or pads as these can scratch the surface which will weaken the glass and cause premature failure

When Not in Use

If the fire is going to be out of use for a long period (for instance in the summer) then to prevent condensation, and hence corrosion, the air control should be left fully open and the fire door left ajar. It is also advisable to sweep the chimney and clean out the fire. Spraying the inside of the door and firebox with a light oil, such as WD40, will also help to keep all internal parts working well. After long periods where the fire has been out of use, the chimney and appliance flueways should be cleaned before lighting.

Door Seals

For the fire to operate correctly it is important that the door seals are in good condition. Check that they do not become worn or frayed and replace them when necessary.

Servicing

It is recommended that the fire is serviced once a year to keep it in first class working order. After cleaning out the firebox thoroughly, check that all internal parts are in good working order, replacing any parts that are beginning to show signs of wear. Check that the door seals are in good condition and that the doors seal correctly. A servicing guide is available on request. Repairs or modifications may only be carried out by the Manufacturer or their approved agents. Use only genuine Charnwood replacement parts.

THROAT PLATE AND FLUEWAY CLEANING

It is important that the throat plate and all the stove flueways are kept clean in order to prevent potentially dangerous fume emission. They should be cleaned at least monthly, and more frequently if necessary. It is necessary to let the fire out to carry out these operations.

To remove the throat plate, first remove the fuel retainer (item 'e' page 4) and one side fire plate to allow enough room so that the throat plate clears the sides of the fire box when removed.

Carefully remove the joining bracket between the bricks and then lift the two pieces down from the top of the side/ back bricks. Sweep any sooty deposits from the top of the throat plate into the fire.

Lift up the upper baffle plate (Island II only) so the hole clears the hook at the front of the firebox, slide to the left or the right and tilt down. Clean any deposits. (See Fig. 5.) The upper baffle plate is positioned on top of the air tubes in the top of the firebox and is held in place by a hook at the front.

To re-fit the throat plate bricks, fit each half so that they rest on the side and back bricks, then, making sure the two halves are fitted closely together slide the joining clip onto the front edge making sure that it is central on the join. Slide the throat plate brick back so that it rests on both side bricks and the back bricks (see Fig 5).

Fig.5 Throat Plate Location

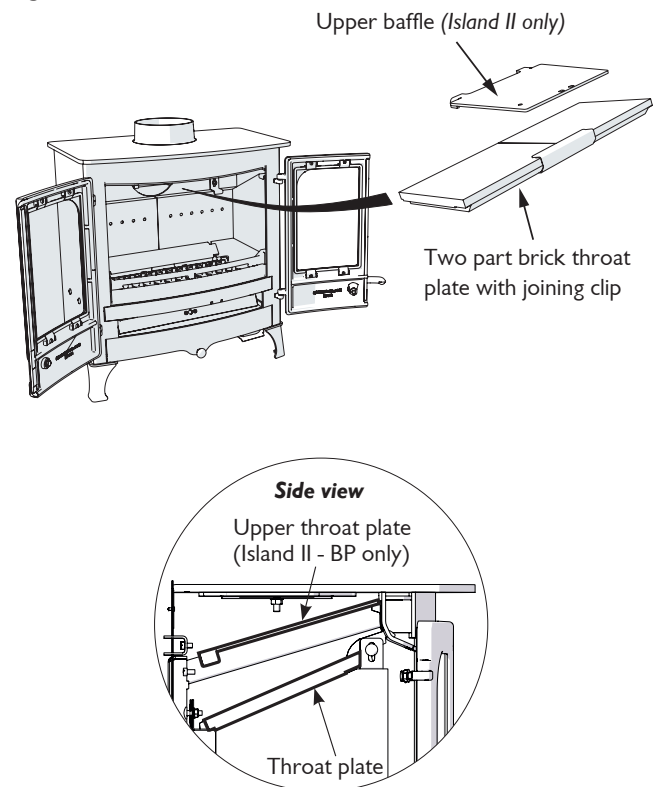

CHIMNEY SWEEPING

Where the chimney previously served an open fire, it is possible that the higher flue gas temperature from a stove may loosen soot deposits with the consequent risk of flue blockage. It is therefore recommended that the chimney be swept a second time within a month of regular use after installation.



The chimney should be swept at least twice a year. Where the top outlet or vertical rear flue connector is used it will generally be possible to sweep the chimney through the appliance.

First remove the fuel retainer and the throat plate. Then sweep the chimney ensuring that soot is removed from all horizontal surfaces after sweeping.

In situations where it is not possible to sweep through the appliance the installer will have provided alternative means, such as a soot door. After sweeping the chimney the appliance flue outlet and the flue pipe connecting the stove to the chimney must be cleaned with a flue brush.

After clearing any soot from within the stove, replace the throat plate (see Fig. 5) and the fuel retainer.

Different types of sweep's brushes are available to suit different flueways. For prefabricated insulated chimneys the manufacturers instructions with regard to sweeping should be consulted.

TROUBLE SHOOTING

Fire Will Not Burn

Check that:

- the air inlet is not obstructed in any way,
- chimneys and flueways are clear,
- a suitable fuel is being used,
- there is an adequate air supply into the room,
- If an extractor fan is fitted, that it is not causing lack of flue draft when operating.
- there is sufficient draw in the chimney. Once the chimney is warm a draught reading of at least 1.25 mm (0.05 in.) water gauge (12Pa) should be obtained.

Blackening of Door Glass

Differences in chimney draughts mean that the best settings of the air controls will vary for different installations. A certain amount of experimentation may be required, however the following points should be noted and with a little care should enable the glass to be kept clean in most situations:

- Wet or unseasoned wood, or logs overhanging the front fence will cause the glass to blacken.
- The airwash relies on a supply of heated air to keep the glass clean,

therefore, when lighting the stove allow the firebed to become well established before closing the air control. This may also be necessary when re-fuelling the stove.

- When re-fuelling keep the fuel as far back from the front fence as possible, do not try to fit too much fuel into the firebox.
- Do not completely close the air control.

It is always more difficult to keep the glass clean when running the stove very slowly for long periods.

If blackening of the glass still occurs check that all flue connections and the blanking plate are well sealed. It is also important that the chimney draw is sufficient and that it is not affected by down-draught. When the chimney is warm a draught reading of at least 1.25 mm (0.05 in.) water gauge (12Pa) should be obtained. Some blackening of the glass may occur below the level of the fuel retainer. This will not obscure the view of the fire or affect its performance.

Fume Emission

Warning Note: Properly installed and operated this appliance will not emit fumes. Occasional fumes from de-ashing and re-fuelling may occur. Persistent fume emission is potentially dangerous and must not be tolerated. If fume emission does persist, then the following immediate actions should be taken:

- Open doors and windows to ventilate the room and then leave the premises.**
- Let the fire out and safely dispose of the fuel from the appliance.**
- Check for flue or chimney blockage, and clean if required.**
- Do not attempt to re-light the fire until cause of fuming has been identified, if necessary seek professional advice.**

The most common cause of fume emission is flueway or chimney blockage. For your own safety these must be kept clean.

Fire blazing out of control

Check that:

- The door is tightly closed.
- The air control slider is fully closed.
- A suitable fuel is being used.
- Door seals and airwash slide are intact.

Chimney Fires

If the chimney is thoroughly and regularly swept, chimney fires should not occur. However, if a chimney fire does occur close the air control, and tightly close the door of the appliance. This should cause



the chimney fire to go out in which case the controls should be kept closed until the stove has gone out. The chimney and flueways should then be cleaned. If the chimney fire does not go out when the above action is taken then the fire brigade should be called immediately. After a chimney fire the chimney should be carefully examined for any damage. Expert advice should be sought if necessary.

CO ALARM

Your installer should have fitted a CO alarm in the same room as the appliance. If the alarm sounds unexpectedly, follow the instructions given under “Warning Note” above.

IF YOU NEED FURTHER HELP

If you need further help with your Charnwood then your Installer will be able to provide the answers to most questions. Your Local Charnwood Premier Dealer has a great deal of experience and will also be able to provide helpful advice. Further help is available from the Charnwood Customer Services department who will be pleased to give advice, if necessary.



UNPACKING THE STOVE

The stove arrives bolted and strapped to its pallet. There must be adequate facilities for unloading and manoeuvring into position. The wrapping is first removed, then the stove released from the pallet by removing 4 pallet bolts using a 10mm spanner. The pallet brackets can now be removed from the stove by tilting it and using a 13mm spanner to remove the bolts. The Stove may now be moved to its final position. The pallet is intended to be cut up and used for kindling fuel.

HEALTH AND SAFETY PRECAUTIONS

Please take care when installing the stove that the requirements of the Health and Safety at Work Act 1974 are met.

Some types of fire cement are caustic and should not be allowed to come into contact with the skin. In case of contact wash with plenty of water.

If there is a possibility of disturbing any asbestos in the course of installation then please use appropriate protective equipment.

Ideally there should not be an extractor fan fitted in the same room as the appliance. If this situation is unavoidable then specialist advice should be taken to ensure that the extractor fan does not cause the appliance to emit fumes into the room. The external air kit will help with this in some situations. Alternatively, an additional air supply correctly positioned may be necessary. It is essential to carry out a spillage test to ensure that the appliance can operate safely when the extractor fan is operating.

There must be an adequate air supply into the room in which the appliance is installed to provide combustion air. The combustion air supply must be via a permanently open vent. The requirement for minimum free area is partly dependent on the design air permeability of the house. In older properties the air permeability will be above $5.0\text{m}^3/(\text{h}\cdot\text{m}^2)$, but in some modern properties it may be less. The vent must be positioned such that it is not liable to blockage. Minimum areas are given in the following table:

AIR PERMEABILITY $\text{m}^3/(\text{h}\cdot\text{m}^2)$	MINIMUM VENT AREA $\text{cm}^2(\text{in}^2)$	
	ISLAND I - AP	ISLAND II - BP
>5.0	No requirement	16.5 (2.6)
<5.0	27.5 (4.3)	44 (6.8)

A fixed ducted air supply may be used as an alternative to the traditional method of using a permanent open vent into a room to supply air for combustion.

External air supply kits are available please contact Charnwood for more information. Instruction sheet ref: TIS 120

This stove is capable of intermittent operation, and is not suitable for use in a shared flue system.

In addition to these instructions the requirements of BS.8303 and BSEN 15287-1:2007 must be fulfilled. Local Authority Bylaws and Building Regulations, including those referring to national and European Standards, regarding the installation of Solid Fuel burning appliances, flues and chimneys must also be observed.

CO ALARMS

Building regulations require that whenever a new or replacement fixed solid fuel or wood/biomass appliance is installed in a dwelling a carbon monoxide alarm must be fitted in the same room as the appliance. Further guidance on the installation of the carbon monoxide alarm is available in BS EN 50292:2002 and from the alarm manufacturer's instructions. Provision of an alarm must not be considered a substitute for either installing the appliance correctly or ensuring regular servicing and maintenance of the appliance and chimney system.

SPECIFICATION

SPECIFICATION	ISLAND I - AP		ISLAND II - BP	
<i>Fuel</i>	<i>Wood logs</i>	<i>Smokeless Fuel</i>	<i>Wood logs</i>	<i>Smokeless Fuel</i>
<i>Rated Heat Output kW (BTU/hr)</i>	5.0	5.0	8.0	8.0
<i>Stove Weight kg (Packed)</i>	114	114	133	133
<i>Flue Temperature °C</i>	232	271	270	284
<i>Minimum Flue Draught</i>	12Pa	12Pa	12Pa	12Pa
<i>Flue gas Mass Flow g/s</i>	3.7	3.6	6.5	6.2
<i>Hearth Temperature</i>	<100	<100	<100	<100
Minimum distance from combustibles mm	SIDE	REAR	SIDE	REAR
<i>With Uninsulated Flue</i>	500	500	480	500
<i>With Insulated Flue and Heat shield</i>	500	100	480	170
<i>The outputs in the table are based on a 45 minute re-fuelling cycle burning seasoned hardwood logs. All tests are carried out in accordance with BSEN 13240.</i>				



CHIMNEY

In order for the appliance to perform satisfactorily the chimney height must not be less than 4 metres measured vertically from the outlet of the stove to the top of the chimney. The internal dimensions of the chimney should preferably be 150-200 mm (6" - 8") either square or round and **MUST NOT BE LESS THAN 125 mm (5")** - Island I - AP, 150 mm (6") Island II - BP.

If an existing chimney is to be used it must be swept and checked, it must be in good condition, free from cracks and blockages, and should not have an excessive cross sectional area. If it was previously used by an open fire then the chimney should be swept one month after installation to clear any soot falls which may have occurred due to the difference in combustion between the stove and the open fire. If you find that the chimney is in poor condition then expert advice should be sought regarding the necessity of having the chimney lined. If it is found necessary to line the chimney then a lining suitable for Solid Fuel must be used.

If there is no existing chimney then a prefabricated block chimney or a twin walled insulated stainless steel flue to BSEN 15287-1:2007 can be used either internally or externally. These chimneys must be fitted in accordance with the manufacturers instructions and Building Regulations.

Single wall flue pipe is suitable for connecting the stove to the chimney but is not suitable for using for the complete chimney. If it is found that there is excessive draw in the chimney then a draught stabiliser should be fitted.

It is important that there is sufficient draw in the chimney and that the chimney does not suffer from down-draught. When the chimney is warm the draw should be not less than 1.25mm (0.05") water gauge (12 Pa). If in doubt about the chimney seek expert advice.

HEARTH AND FIRE SURROUND

The stove must stand on a fireproof hearth and must not be situated closer than the minimum distance from combustible materials (see specification table) to the sides or rear above hearth level unless adequately fireproofed in accordance with local building regulations. The hearth must be of fireproof material and at least 12mm (1/2in.) thick. The positioning of the stove and the size of the hearth are governed by building regulations for Class 1 appliances. These building regulations state that the hearth must extend in front of the stove by at least 225mm (9 in.) and to the sides of the stove by at least 150mm (6 in.). When the fire door is open, it extends beyond

the flat front of the stove by 185mm - Island I, 222mm - Island II - BP.

If in doubt as to the positioning of the stove, expert advice should be sought either from the supplier or the local building inspector. The fireplace must allow good circulation of air around the appliance to ensure that maximum heat is transferred to the room and also to prevent the fireplace from overheating. A gap of 150mm (6") each side and 300mm (12") above the appliance should give sufficient air circulation. If a wooden mantelpiece or beam is used in the fireplace it should be a minimum of 460mm (18"), and preferably 600mm (24") from the appliance. In some situations it may be necessary to shield the beam or mantelpiece to protect it.

In order for the fire to operate correctly and to allow for access, there must be an air gap behind the appliance of at least 50mm, but be aware that this distance will need to be greater in some cases to meet Building Regulation requirements.

The appliance should be installed on a floor with adequate load-bearing capacity. If an existing construction does not meet this requirement then please take suitable measures to achieve this. (e.g. load distributing plate.)

CONNECTIONS TO FLUES

The stove must be connected to the flue using flue pipe of 125mm (5") diameter - Island I - AP, 150 mm (6") Island II - BP.

If using twin wall flue, the flue collar must be shielded to protect exposed combustible material. This can be done with a shielded starter length of flue.

Fig. 3 Shielding the flue spigot

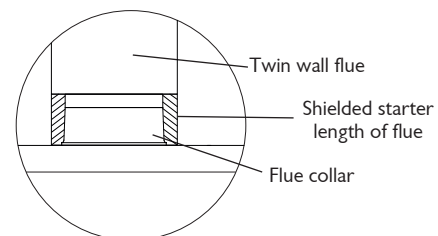

This may be stainless steel, cast iron, or thick wall steel pipe. Charnwood Pipe to match the stove is available if required.

There are several ways of connecting the stove to the flue. These are illustrated in Figs. 6 to 9.

If the top flue connection or optional vertical rear flue connector is used then the chimney may be swept through the appliance.

INSTALLATION INSTRUCTIONS



Horizontal lengths of flue must be kept to a minimum and should not be more in length than the flue diameter.

The stove comes with the blanking plate (fig. 10) fitted to the top flue outlet. The seal for the top outlet is a 155mm dia ring of rope seal. The seal for the rear outlet is a length of adhesive backed fibre webbing supplied with instructions ref: TIS093. This is applied to the flue collar or the Vertical Rear Flue adapter for rear outlet installations. For top outlet installations, the blanking plate must be removed, have the webbing fitted to its sealing face, and fitted to the rear flue outlet. Ensure that the fold on the clamping plate is in line with the lugs on the firebox as shown in Fig 10. Ensure that the clamping plate does not prevent the throat plate from seating correctly. All flue connections must be well sealed.

Fig. 6 Vertical Register Plate With Bricked Up Fireplace

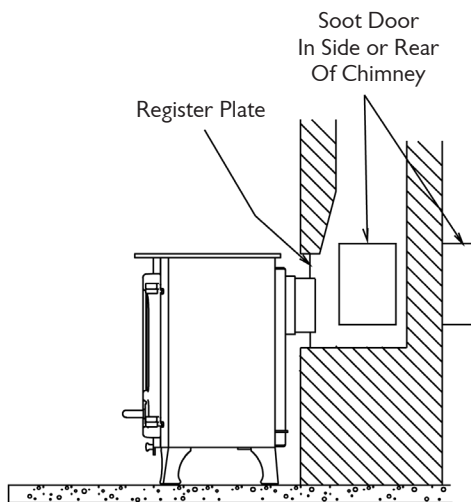

Fig. 7 Horizontal Register Plate With Rear Flue Connection

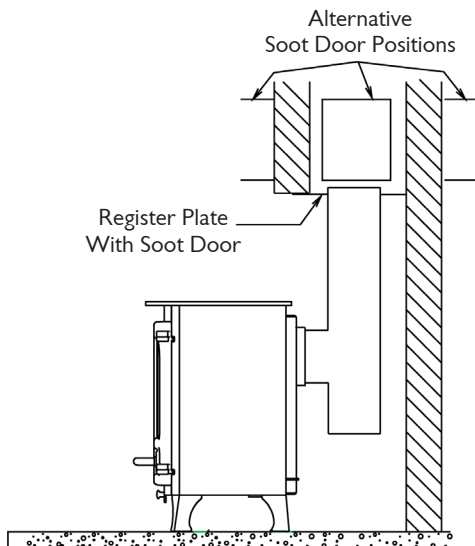

Fig. 8 Horizontal Register Plate With Top Flue Connection

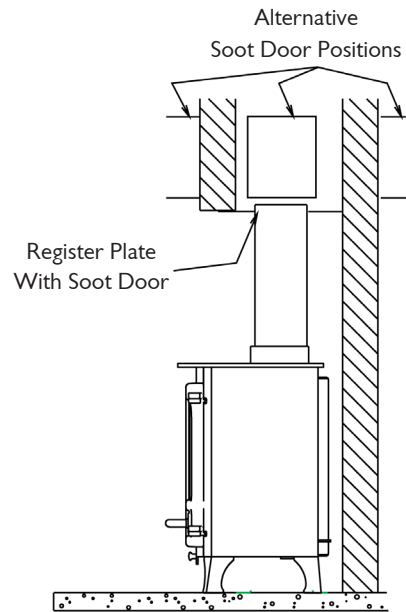
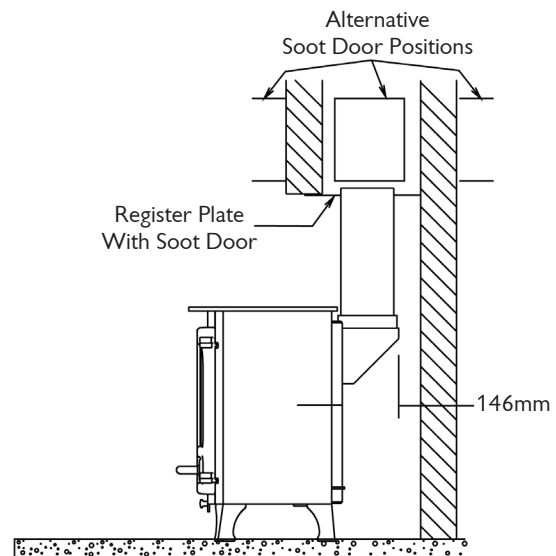

Fig. 9 Horizontal Register Plate With Optional Vertical Rear Flue Connector



SOOT DOORS

It is possible to pass a 16 inch diameter sweeps brush through the appliance but in most back outlet installations it will be necessary to have a soot door to enable the chimney to be swept. The optional vertical rear flue connector does allow the chimney to be swept through the stove. Soot doors may either be in the actual brickwork of the chimney or in the register plate. Various positions of soot doors are shown in Figs. 6 to 9.



PRE LIGHTING CHECK

Ensure that the throat plate is fitted in the roof of the appliance. The location and positioning of the throat plate is shown in Fig. 5.

Check that the front fence is fitted correctly and that the door closes properly.

COMMISSIONING

On completion of the installation allow a suitable period of time for the fire cement and mortar to dry out before lighting the fire. Make a layer of ash or sand on the base of the stove before lighting. Check to ensure that smoke and fumes are taken from the appliance up the chimney and emitted safely. Also check all joints and seals. On completion of the installation and commissioning please leave the operating instructions with the customer and advise them on the use of the appliance.

CAA AND SMOKE CONTROL

The Clean Air Act 1993 and Smoke Control Areas

Under the Clean Air Act local authorities may declare the whole or part of the district of the authority to be a smoke control area. It is an offence to emit smoke from a chimney of a building, from a furnace or from any fixed boiler if located in a designated smoke control area. It is also an offence to acquire an “unauthorised fuel” for use within a smoke control area unless it is used in an “exempt” appliance (“exempted” from the controls which generally apply in the smoke control area).

In England appliances are exempted by publication on a list by the Secretary of State in accordance with changes made to sections 20 and 21 of the Clean Air Act 1993 by section 15 of the Deregulation Act 2015. Similarly in Scotland appliances are exempted by publication on a list by Scottish Ministers under section 50 of the Regulatory Reform (Scotland) Act 2014.

In Northern Ireland appliances are exempted by publication on a list by the Department of Agriculture, Environment and Rural Affairs under Section 16 of the Environmental Better regulation Act (Northern Ireland) 2016.

In Wales appliances are exempted by regulations made by Welsh Ministers.

Further information on the requirements of the Clean Air Act can be found here: <https://www.gov.uk/smoke-control-area-rules>

Your local authority is responsible for implementing the Clean Air Act 1993 including designation and supervision of smoke control areas and you can contact them for details of Clean Air Act requirements.

The Island I - AP and Island II - BP have been recommended as suitable for use in smoke control areas when burning wood logs. The stove includes a factory-fitted modification to the air control to prevent complete closure of the air supply. Suitable Authorised fuels can also be burned within Smoke Control Areas. A list of Authorised fuels can be found here: <https://smokecontrol.defra.gov.uk/fuels.php>.

Fig. 10. Flue Blanking Plate.

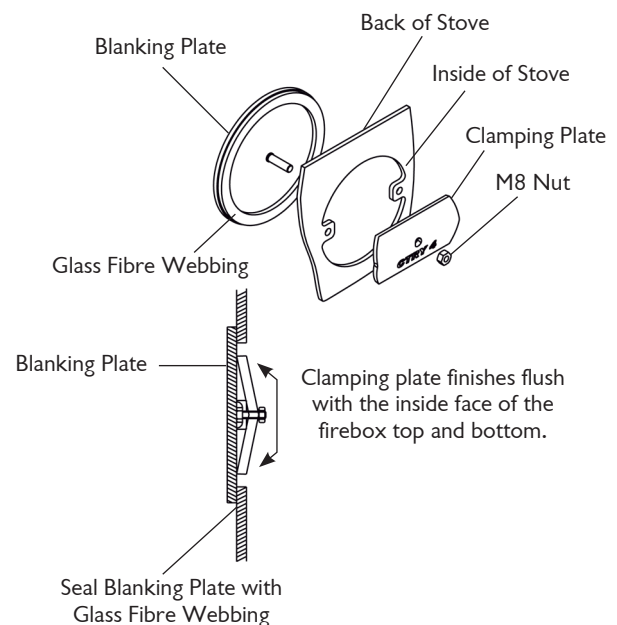

DIMENSIONS ISLAND I - AP



PLAN VIEW

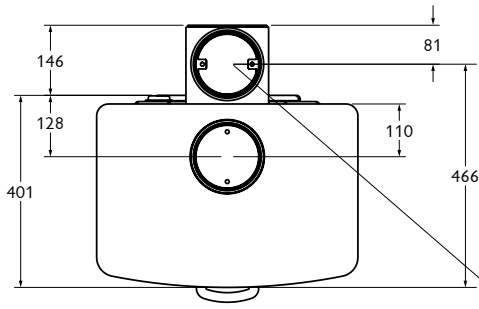

Optional rear flue adaptor

To suit 125mm (5") flue pipe

LOW LEG

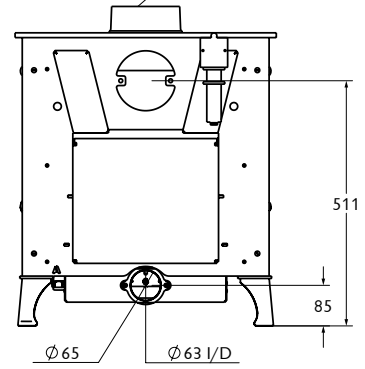
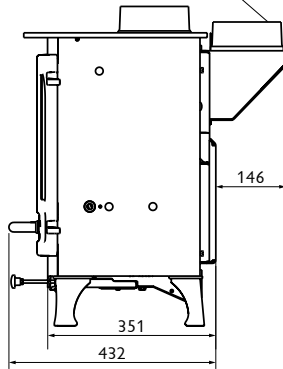
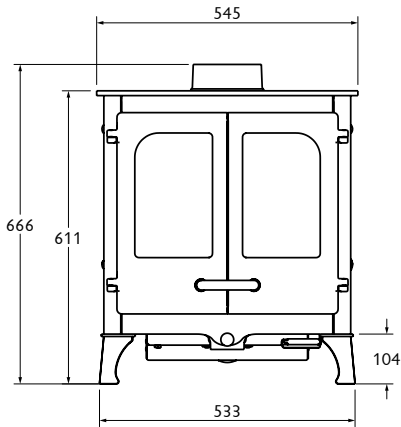

HIGH LEG

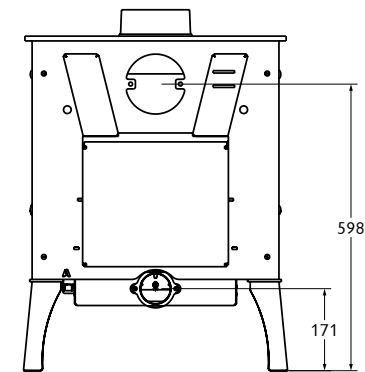
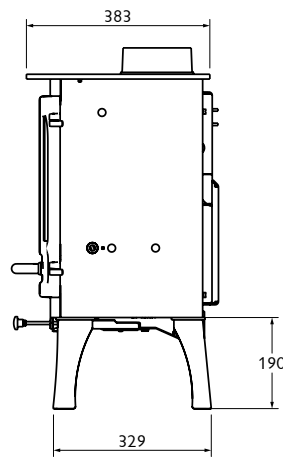
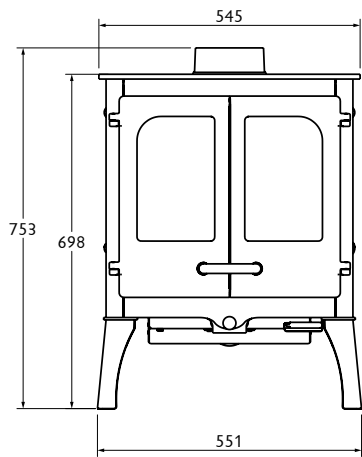

STORE STAND

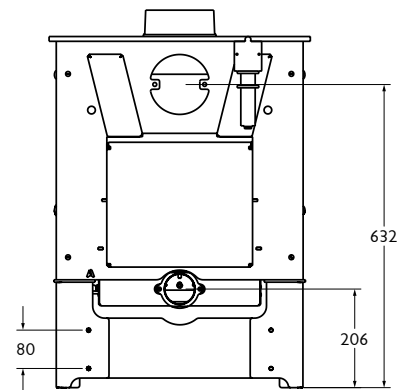
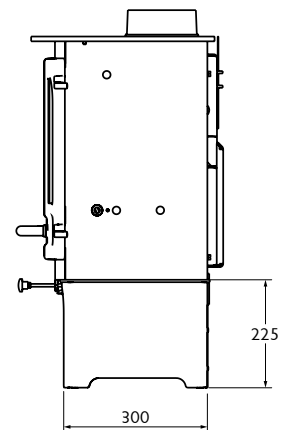
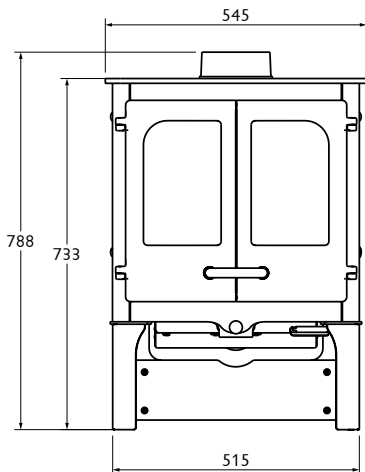

FRONT

SIDE

REAR

DIMENSIONS ISLAND II - BP

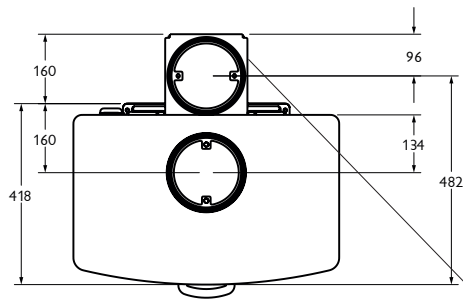

PLAN VIEW

Optional rear flue adaptor

To suit 150mm (6") flue pipe

LOW LEG

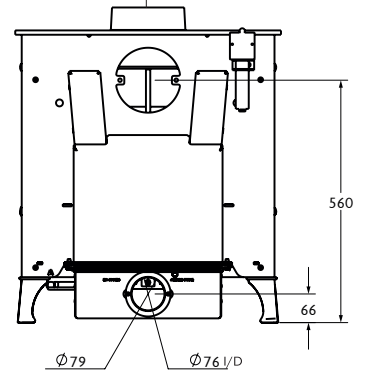
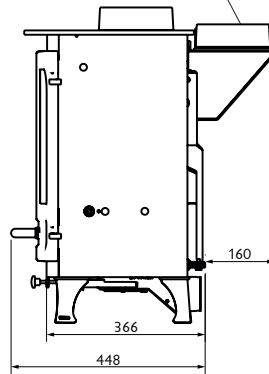
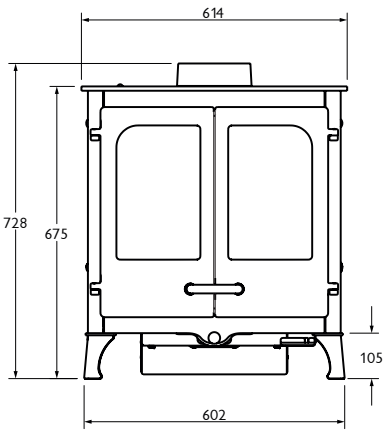

HIGH LEG

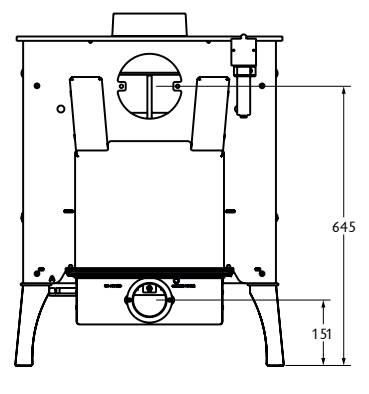
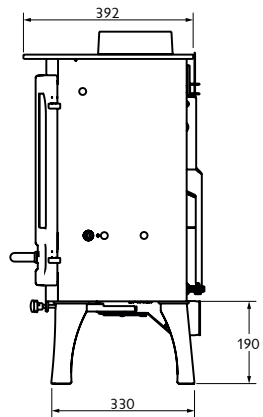
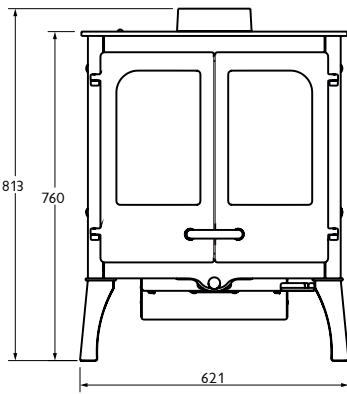

STORE STAND

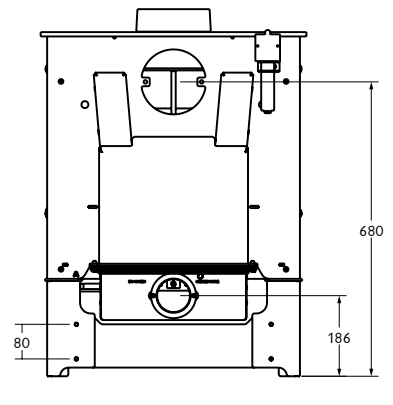
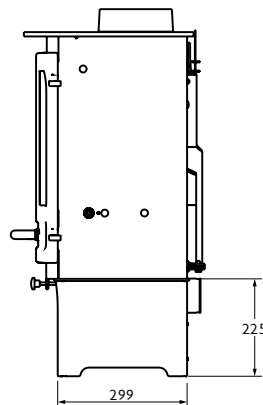
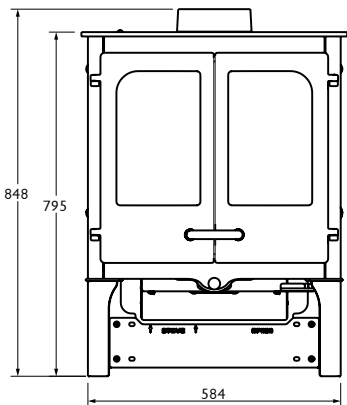

FRONT

SIDE

REAR

Charnwood Island I (AP) Parts List

Issue C

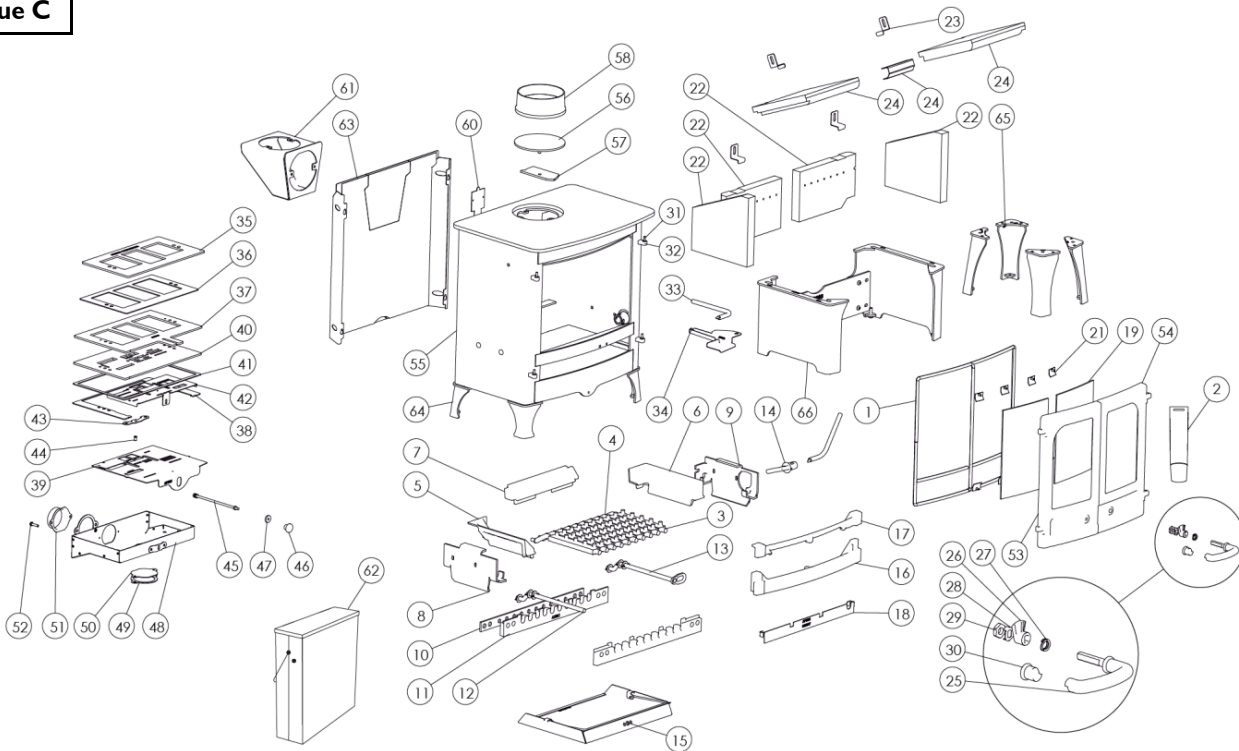

Item	Part No.	Description
1	008/AP62S	Door Seal Set Inc. Adhesive
2*	008/TH085	Door Seal Adhesive
3	002/CG20	Bottom Grate Bar
4	002/CG20S10	Set of Grate Bars (10)
5	002/BU015L	LH Side Fire Plate
6	002/BU015R	RH Side Fireplate
7	002/AU016	Back Fireplate
8	010/AP039	LH Carrier Bar Support
9	010/AP040	RH Carrier Bar Support
10	010/AU033	Mover Bar
11	002/AY30	Carrier Bar
12	012/FW14	Riddler Rod
13	010/BU077	Driver Bar Assembly
14	002/AP098	Riddler Spigot
15	004/AP017	Ashpan
16	002/AP007	Front Firebar
17	002/AP008	Deepening Bar
18	004/AP052	Front Ash Shedding Plate
19	006/AP018	Glass
20*	008/AY45	Glass Seal
21	004/KV23	Glass Retainer
22	011/AP029S	Set of Fire Bricks (3)
23	004/XV30	Brick Bracket
24	011/AP031S	Set of Throat Plate Bricks Inc. Bracket
25	008/KV16	Handle
26	002/AY14	Catch
27	008/FFW015	Thackery Washer
28	004/ST008	Tab Washer
29	008/FFN001	12mm Halfnut
30	008/KV13	L.H. Door Knob
31	008/ST068/4	Hinge Pin Set (4)
32#	002/AP024	Hinge Post
33	004/EZ095	Ashpan/Riddling Tool

Item	Part No.	Description
34	004/AP051	Tool Holder
35	010/AP116	Air Box Spacer
36	008/AP036	Air Control Gasket
37	010/AP037	Air Control Top Slider Plate
38	004/AP033	Wood/Multifuel Surround Plate
39	004/AP035	Wood/Multifuel Selection Slide
40	010/AP130	Air Control Lower Plate
41	008/AP045	Air Box Gasket
42	004/AP020	Air Control Slider
43	004/BR015	Clicker Retainer Plate
44	008/ES36/01	Brass Ball Catch
45	004/GR086	Air Control Rod
46	008/AY37	Air Control Knob
47	008/BR052	Felt Washer
48	004/AP060	Air Box Cover
49	008/BR044	Blanking Plate Gasket
50	004/BR054	Coverplate
51	004/BR053	Air Inlet Spigot
52	008/FFS062	M6 x 25 Hex Hd
53#	003/AP001A	LH Door Assembly
54#	003/AP002A	RH Door Assembly
55#	001/AP010	Firebox (Island I AP)
56	012/PV09	Blanking Plate
57	010/EY51	Clamping Plate
58#	002/PV12B	Flue Collar
59	008/EY38	Flue Fixing Rope Seal
60	012/AP011	Serial No Label
61#	010/BU034	Vertical Rear Flue Adapter (Optl. Extra
62	010/EW51	Ash Carrier (size 1)
63#	010/AP057A	Heatshield (Opt'l Extra)
64#	010/BP012S	Set of Low Legs (Option)
65#	010/AY85S	Set of High Legs (Option)
66#	010/BP087	Store Stand (Option)

*These items are not shown on the drawing.

Please specify colour when ordering. Prices are shown in pounds sterling with vat at 20% They are correct at the date shown but may be subject to change without notice. E. & O.E These prices are subject to a carriage charge.

To obtain spare parts please contact your local stockist giving Model, Part No. and Description. In case of difficulty contact the manufacturer at the address shown. This drawing is for identification purposes only.

Charnwood Island II (BP) Parts List

Issue G

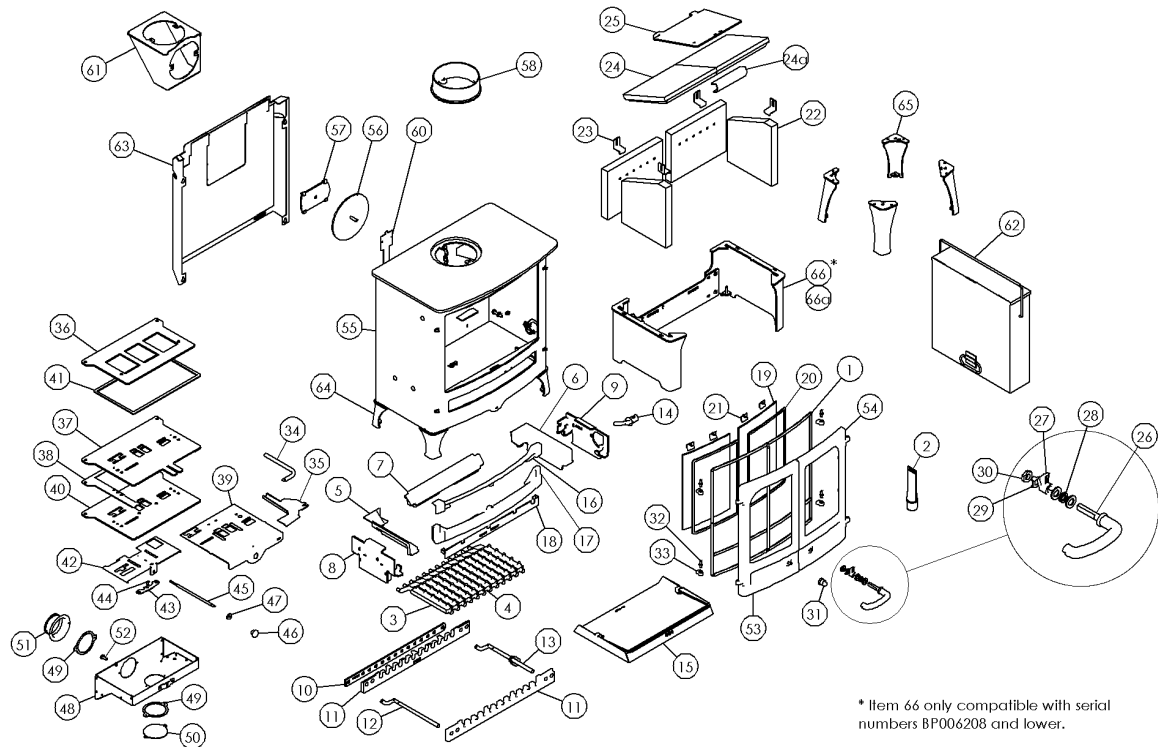

* Item 66 only compatible with serial numbers BP006208 and lower.

Item	Part No.	Description	Item	Part No.	Description
1	008/BP035	Door Seal Set Inc. Adhesive	34	004/EZ095	Ashpan/Riddling Tool
2*	008/TH085	Door Seal Adhesive	35	004/AP051	Tool Holder
3	002/CG20	Bottom Grate Bar	36	008/BP110	Air Control Gasket
4	002/CG20S12	Set of Grate Bars (12)	37	010/BP111	Air Control Top Slider Plate
5	002/BU015L	LH Side Fire Plate	38	004/BP112	Wood/Multifuel Surround Plate
6	002/BU015R	RH Side Fireplate	39	004/BP113	Wood/Multifuel Selection Slide
7	002/BP016	Back Fire Plate	40	010/BP114	Air Control Lower Plate
8	010/BP039	LH Carrier Bar Support	41	008/KZ006	Airbox Gasket
9	010/AP040	RH Carrier Bar Support	42	004/BP115	Air Control Slider
10	010/BP033	Mover Bar	43	004/BR015	Clicker Retainer Plate
11	002/BY30	Carrier Bar	44	008/ES36/01	Brass Ball Catch
12	012/FW14	Riddler Rod	45	004/EZ016	Control Rod
13	010/BU077	Driver Bar Assembly	46	008/AY37	Air Control Knob
14	002/AP098	Riddler Spigot	47	008/BR052	Felt Washer
15	004/BP017	Ashpan	48	004/KZ039	Air Box Cover
16	002/BP008	Deepening Bar	49	008/CR063	Blanking Plate Gasket
17	002/BP007	Front Fence (Lower)	50	004/CR064	Coverplate
18	004/BP052	Front Ash Shedding Plate	51	010/CR048/S	Air Inlet Spigot
19	006/BP018	Glass	52	008/FFS062	M6 x 25 Hex Hd
20	008/BP045	Glass Seal	53#	003/BP001A	LH Door Assembly
21	004/KV23	Glass Retainer	54#	003/BP002A	RH Door Assembly
22	011/BP029S	Set of Fire Bricks (4)	55	001/BP010	Firebox (Island II BP)
23	004/XV30	Brick Bracket	56	012/TW09	Blanking Plate
24	011/BP031S	Set of Throatplate Bricks (2)	57	010/AY51	Clamping Plate
24a	004/AC032	Throat Plate Joining Clip	58#	002/CH12B	Flue Collar
25	010/BP032	Upper Throatplate	59*	008/NV38	Flue Fixing Rope Seal (10mm Dia)
26	008/KV16	Handle	60	012/BP011	Serial No. Label
27	002/AY14	Catch	61#	010/TW33	Vert Rear Flue Adaptor (Opt'l Extra)
28	008/FFW015	Thackery Washer	62	010/BW51	Ash Carrier (size 3)
29	004/ST008	Tab Washer	63#	010/BP080	Heatshield
30	008/FFN001	12mm Halfnut	64#	010/BP012S	Set of Low Legs (Option)
31	008/KV13	L.H. Door Knob	65#	010/AY85S	Set of High Legs (Option)
32	008/ST068/4	Hinge Pin Set (4)	66#	010/BP087	Store Stand (Option)
33#	002/AP024	Hinge Post	66a#	010/BP050	Store Stand (option)

*These items are not shown on the drawing.

Please specify colour when ordering. Prices are shown in pounds sterling with vat at 20% They are correct at the date shown but may be subject to change without notice. E. & O.E These prices are subject to a carriage charge.

To obtain spare parts please contact your local stockist giving Model, Part No. and Description. In case of difficulty contact the manufacturer at the address shown. This drawing is for identification purposes only.



charnwood



AJ WELLS & SONS LTD

Bishops Way, Newport, Isle Of Wight PO30 5WS, United Kingdom
A Division of A.J.Wells & Sons Limited Registered In England No. 03809371



EN16510-1:2022 / EN16510-2-1:2022

ROOMHEATER

Model:	ISLAND I - AP	ISLAND I - AP	ISLAND II - BP	ISLAND II - BP
EC Certificate of conformity no:	AP11-CPD-2018	AP11-CPD-2018	BP11-CPD-2018	BP11-CPD-2018
Fuel type:	WOOD LOGS	SOLID FUEL	WOOD LOGS	SOLID FUEL
Rated space heating thermal output:	5kW	5kW	8kW	8kW
Emission of CO in combustion products:	0.09	0.08	0.08	0.08
Mean flue gas temperature:	232	271	270	284
Energy efficiency:	85	78.8	82	79
Particles (mg/m ³ , _n)	9	7	14	12
Minimum distance to combustible materials with Uninsulated flue				
Side:	500mm	500mm	480mm	480mm
Rear:	500mm	500mm	500mm	500mm
Minimum distance to combustible materials with Insulated flue & rear heat shield				
Side:	500mm	500mm	480mm	480mm
Rear:	100mm	100mm	170mm	170mm
Fulfilled requirements: BStV of the City of Munich and the City of Regensburg FBStVO of the City of Aachen and the City of Düsseldorf 1.and 2. level of 1. BImSchV of Germany	✓	✓	✓	✓

All product related data available here:

<https://www.charnwood.com/conformance-documentation>

your premier dealer

charnwood BISHOPS WAY, NEWPORT, ISLE OF WIGHT PO30 5WS, UNITED KINGDOM
TEL. +44 (0) 1983 537777 • FAX. +44 (0) 1983 537788 • WWW.CHARNWOOD.COM

A Division of A.J. Wells & Sons Limited Registered in England No. 03809371