

C-FOUR & C-FIVE DUO

Operating & Installation Instructions

CONTENTS

QUICK GUIDE	4
OPERATING INSTRUCTIONS	5
FUEL	5
LIGHTING	5
CONTROLLING THE FIRE	6
REFUELLING	6
ASH CLEARANCE	7
REDUCED BURNING	7
MAINTENANCE	7
THROAT PLATE AND FLUEWAY CLEANING	7
CHIMNEY SWEEPING	8
TROUBLE SHOOTING	8
CO ALARM	9
IF YOU NEED FURTHER HELP	9
INSTALLATION INSTRUCTIONS	10
UNPACKING THE STOVE	10
HEALTH AND SAFETY PRECAUTIONS	10
CO ALARMS	10
SPECIFICATION	10
CHIMNEY	11
HEARTH AND FIRE SURROUND	11
CONNECTIONS TO FLUES	11
SOOT DOORS	12
PRE LIGHTING CHECK	12
COMMISSIONING	12
CAA AND SMOKE CONTROL	13
COOKING PLATE	13
C FOUR DUO DIMENSIONS	14
C FIVE DUO DIMENSIONS	15
C FOUR DUO PARTS LIST	16
C FIVE DUO PARTS LIST	17
CE CERTIFICATE	18

QUICK GUIDE

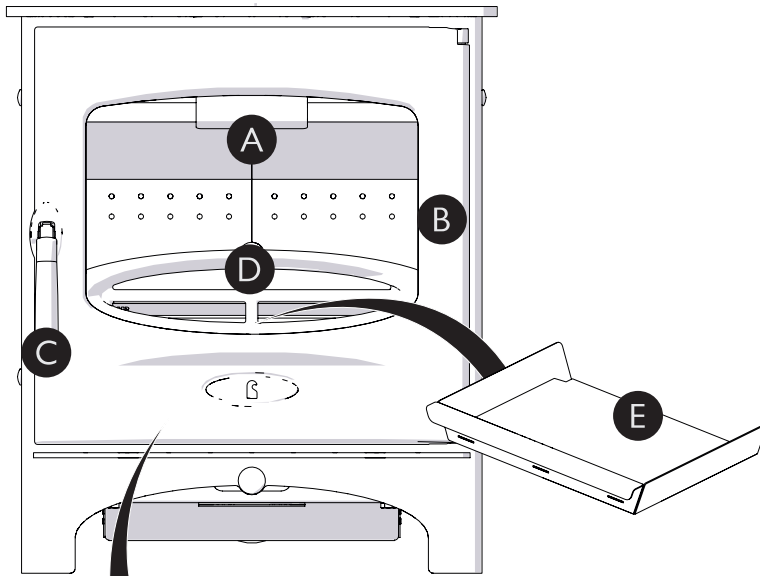

- A Throat plate**
Improves efficiency of stove by slowing down flue gases
- B Door**
Keep closed when stove is in use
- C Door handle**
Pull to open
- D Front Fence**
Protects glass and prevents spillage
- E Sliding Ashpan**
For clean and easy ash removal

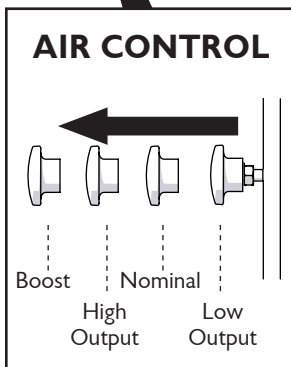

MAINTENANCE AND CLEANING

GLASS

Wipe with damp, lint free cloth. Any stubborn deposits on the glass may be removed with a proprietary stove glass cleaner or ceramic hob cleaner.

THROAT PLATE & UPPER BAFFLE

Take down once a month and clean. Sweep sooty deposits into fire

CHIMNEY

Have chimney swept twice a year. Chimney can be swept through stove.

SERVICING

Stove should be serviced by a professional at least once a year.

LIGHTING AND CONTROLLING THE FIRE

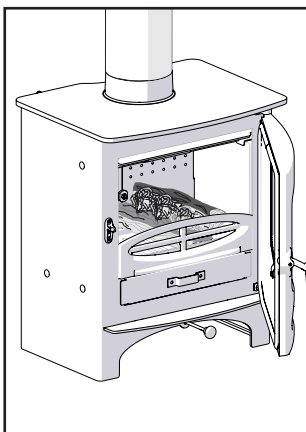

Place 2-3 dry well seasoned logs into the bottom of the firebox. Keep air control fully out.

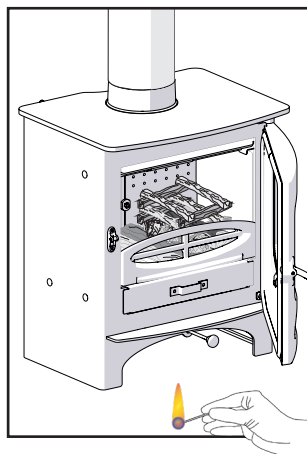

Build a stack of 6-8 softwood kindling sticks. This can be in grid shape or a pyramid, ensure to leave a space between the pieces to allow the air to circulate round and through them. Add paper or a firelighter and light. Leave the door cracked open while the flame is established, close it once the kindling begins to light.

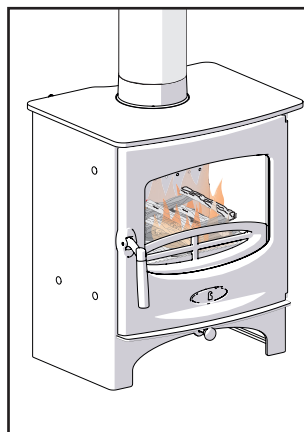

Add larger logs once fire is established. Air control can be reduced to minimum.

Suitable fuels for your

Charnwood:
Wood logs
Smokeless mineral fuel

Unsuitable fuels:

Petroleum coke
Liquid fuel
Household waste
Coal singles
Small nuts or coal dust
Wet or unseasoned wood



Congratulations on becoming the owner of a Charnwood C - Series Duo Stove. Your stove has been approved in smoke control areas to burn wood logs if it is used in accordance with these instructions. It is very important that you read and understand these instructions before using the stove.

Before lighting the stove check with the installer that the work and checks described in the Installation Instructions have been carried out correctly and that the chimney has been swept, is sound and free from any obstructions. The stove is not suitable for use in a shared flue system.

If you are using your stove to burn wood logs in a smoke controlled area, then the provided Defra Stop **MUST** be fitted and the instructions on lighting and refuelling **MUST** be followed. This stove will not produce significant smoke if well seasoned logs of less than 20% moisture content are burnt and these instructions are adhered to. Burning wet (>20% moisture content) wood and operating the stove in an irresponsible manner may produce smoke which is illegal in smoke controlled areas.

Remember that the stove will be hot and that it is made from hard materials – ensure that you have good balance before operating the fire. Always use the provided operating tool and gloves.

Do not use an aerosol spray on or near the stove when it is alight. There is a risk of explosion or flash ignition of the spray.

When using the stove in situations where children, aged and/or infirm persons are present a fireguard must be used to prevent accidental contact with the stove. The fireguard should be manufactured in accordance with BS 8423:2002.

The stove is suitable for intermittent operation.

FUEL

Please pay careful attention to the special points made with each type of fuel as they will help you to get the best from your stove. It must be remembered that only authorised fuels and wood logs may be burnt in smoke control areas on this stove. If you are not sure whether you are in a smoke control area, please check with your Local Authority. At first you may find it helpful to try several fuels to find the most suitable. If you are unable to obtain the fuel you want, ask your supplier, or an approved fuel distributor, to suggest an alternative.

Authorised Mineral Fuels

Authorised mineral fuels may be burned in smoke control areas on this appliance. Your local fuel supplier or stove shop will be able to advise you which fuels are available locally. A list of authorised fuels can be found at:

<https://smokecontrol.defra.gov.uk/fuels.php>

Take care to only burn good quality fuels in order to obtain the greatest efficiency and to maintain the life of the appliance.

When burning mineral fuels, for best performance the deflector plate on the rear of the fuel retainer should be removed. Use a 10mm spanner to undo the bolts and remove the deflector plate.

Wood Logs

Only dry well seasoned wood should be burnt on this appliance as burning wet unseasoned wood will give rise to heavy tar deposits in the stove, on the glass and within the chimney. For the same reason hard woods (such as Ash, Beech and Oak) are better than soft woods (such as Pine and Spruce). Burning wet unseasoned wood will also result in considerably reduced outputs. The wood should be cut and split and then left to season in a well ventilated dry place for at least one year but preferably two years before use.

Approximate suitable log sizes are:

255mm (10in) long and 75mm (3in) diameter - C Four Duo
305mm(12in) long and 75mm (3in) diameter - C Five Duo

Log moisture content of less than 20% is recommended.

PETROLEUM COKE IS NOT SUITABLE FOR USE ON THIS APPLIANCE. ITS USE WILL INVALIDATE THE GUARANTEE.

This stove is not designed to burn household waste.

LIGHTING

On initial lighting, the stove may smoke and give off an odour as the silicon paint with which the firebox is painted reacts to the heat. This is normal and will cease after a short time, but meanwhile the room should be kept well ventilated.

At first only light a small fire and burn it slowly for two hours to allow any residual moisture in the chimney to evaporate.

First, start by placing 2-3 dry well seasoned logs into the bottom of



the firebox. On top of this build a stack of 6-8 softwood kindling sticks. This can be in grid shape or a pyramid, ensure to leave a space between the pieces to allow the air to circulate around and through them. Ensure that the assembled wood is no higher than the holes on the back bricks of the firebox and that no logs protrude over the front fence. Place natural fire lighters or paper inside, open the air control fully (see Fig. 1) Light the paper or fire lighters. The door may be left cracked open for a few minutes to assist the combustion and heat up the firebox more quickly. When well alight, close the door but leave the air control fully open. When the flames are established around these logs, load the stove with the required fuel load. Maintain the air control at maximum at this stage. Once the fire is up to temperature the airwash system will begin to work, so allow the fire to become hot before adjusting the air control to the required setting. During the lighting period, do not leave the stove unattended. Do not leave the door open except as directed above to avoid excessive smoke.

When relighting the stove, leave the ash on the base, unless it is becoming too deep, in which case some of it may be removed.

CONTROLLING THE FIRE

The rate of burning and hence the output is controlled by the air control (see Fig.1)

Fig. 1 Stove controls

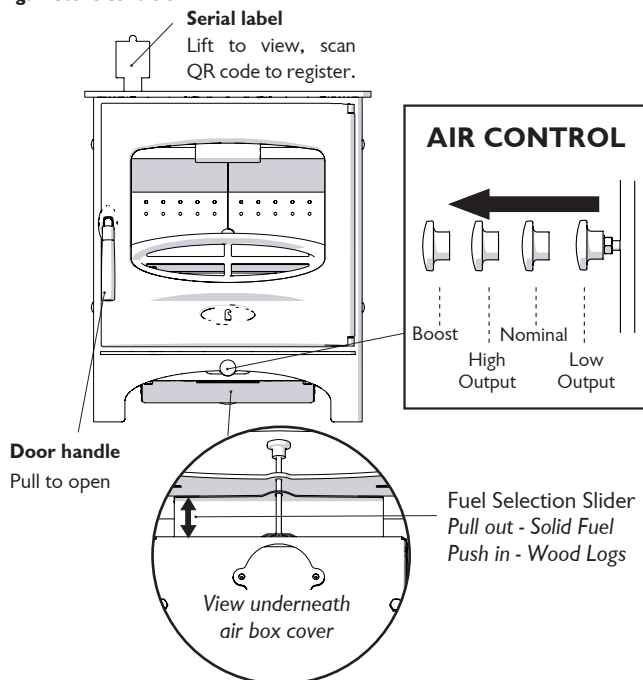

Open the air control fully (boost position) when lighting or when rapid burning is required. It should not be left fully open for long

periods as this can cause over-firing or excessive smoke production. For high output move the air control to the 'click position' or for low burning to the fully closed position.

When the fire is burning normally the air control gives enough airwash to keep the glass clean. However, it will not always be possible to keep the glass clean with the air control fully closed. For correct firing we recommend the use of a stove pipe thermometer which may be purchased from your supplier or from Charnwood.

The Charnwood C Five duo is fitted with an air control stop for use in a smoke control area. This stops the stove from burning too slowly.

When burning solid fuel the fuel selection slider that is located behind the air control handle should be pulled out, when burning wood logs it should be pushed in. (see Fig.1)

When burning wood, ash should be allowed to build up and only cleared when the ash begins to cover the rear fireplate. The ash can be knocked into the ashpan below using a brush and cleared into the sliding ashpan.

REFUELLING

Keep the firebox well filled but do not allow fuel to spill over the top of the fuel retainer. The maximum amount of fuel specified in this manual should not be exceeded, overloading can cause excess smoke.

Logs should be evenly distributed, filling the firebed to give the most pleasing flame pattern. The air control must be fully opened after refuelling until the flames are established above the fire. It is best to refuel on to a hot bed of embers. If at this point the fire starts to die, the door must be cracked open until the fire is revived. If the fire has started to die down before refuelling, then more kindling wood must be added, the air control opened fully and the door cracked open to re-establish the firebed before adding larger logs (see suitable log sizes in Fuel section). This will avoid excessive smoke emission.

If there is insufficient burning material in the firebed to light a new fuel charge, excessive smoke emission can occur. Refuelling must be carried out onto a sufficient quantity of glowing embers and ash that the new fuel charge will ignite in a reasonable period. If there are too few embers in the fire bed, add suitable kindling to prevent excessive smoke.

Care should be taken, especially when burning wood, that fuel does not project over the fuel retainer or damage to the glass may be caused when the door is closed. It can also cause the glass to blacken



up. Maximum filling height is such that logs cannot fall from the fire when the door is opened.

In smoke controlled areas do not fill the stove above the level of the air holes in the back bricks, as overloading can cause excess smoke.

Do not operate with the door open except as directed by the instructions as this can cause excessive smoke.

ASH CLEARANCE

Before removing ash ensure that it has cooled down. The ashpan slides out for easy ash removal.

To make ash removal easier there are ash carriers available. These may be purchased from your supplier or, in case of difficulty, from Charnwood.

The sliding ashpan should be emptied regularly before it becomes too full. Never allow the ash to accumulate in the ashpan so that it comes in contact with the underside of the grate as this could cause serious damage.

REDUCED BURNING

For reduced burning the fire door must be closed.

When burning wood in areas that are not smoke controlled, load some large logs on the fire and allow to burn for half an hour before closing the air control (this will help to reduce tar deposits in the chimney). Some experimentation may be necessary to find the setting most suitable for the type of fuel being used and the draw on the chimney.

MAINTENANCE

Cleaning

The stove is finished with a high temperature paint which will withstand the temperatures encountered in normal use. This may be cleaned with a damp lint-free cloth when the stove is cold. Should re-painting become necessary, high temperature paints are available from your supplier or from stove shops.

Cleaning the Glass

Most deposits on the glass may be burnt off simply by running the fire at a fast rate for a few minutes. If it becomes necessary to clean the glass then open the door and allow it to cool. Clean the glass using a damp cloth and then wiping over with a dry cloth. Any stubborn deposits on the glass may be removed with a proprietary stove glass

cleaner or ceramic hob cleaner. Do not use abrasive cleaners or pads as these can scratch the surface which will weaken the glass and cause premature failure

When Not in Use

If the fire is going to be out of use for a long period (for instance in the summer) then to prevent condensation, and hence corrosion, the air control should be left fully open and the fire door left ajar. It is also advisable to sweep the chimney and clean out the fire. Spraying the inside of the door with a light oil, such as WD40, will also help to keep all internal parts working well. After long periods where the fire has been out of use, the chimney and appliance flueways should be cleaned before lighting.

Door Seals

For the fire to operate correctly it is important that the door seals are in good condition. Check that they do not become worn or frayed and replace them when necessary.

Servicing

It is recommended that the fire is serviced once a year to keep it in first class working order. After cleaning out the firebox thoroughly, check that all internal parts are in good working order, replacing any parts that are beginning to show signs of wear. Check that the door seals are in good condition and that the doors seal correctly. A servicing guide is available on request. Repairs or modifications may only be carried out by the Manufacturer or their approved agents. Use only genuine Charnwood replacement parts.

THROAT PLATE AND FLUEWAY CLEANING

It is important that the throat plate and all the stove flueways are kept clean in order to prevent potentially dangerous fume emission. They should be cleaned at least monthly, and more frequently if necessary. It is necessary to let the fire out to carry out these operations.

The C Five duo throat plate is made up of two bricks and a bracket that slides over the front that holds the two bricks together. The C Four duo throat plate is one brick.

To remove the throat plate, if made up of two pieces, first carefully remove the joining bracket at the front of the throat plate and then lift the two pieces down from the top of the stove. If the throat plate is a single piece, slide the throat plate forwards so that it clears the back brick, then slide it either right or left so that the opposite side clears the top of the remaining side brick and can be gently lowered. Any sooty deposits should then be swept from the throat plate and into the fire.



Lift out the upper throat plate and clean any deposits, then re-fit it as shown in figure 2. If the rear flue connection is used then the upper throat plate is not required.

To re-fit the lower throat plate, if the throat plate is made up of two pieces, fit each half so that it rests on the side and back brick, then, making sure the two halves are fitted closely together, slide the joining clip back onto the front edge, making sure that it is central on the join. If it is a single piece, return the throat plate to its correct position by offering up the throat plate at an angle. Insert the throat plate so that it sits on top of either the right or left side brick. Raise the opposite side and slide so that the throat plate is central and supported by the side bricks. Slide back so that the throat plate rests neatly on the top of the back bricks.

CHIMNEY SWEEPING

Where the chimney previously served an open fire, it is possible that the higher flue gas temperature from a stove may loosen soot deposits with the consequent risk of flue blockage. It is therefore recommended that the chimney be swept a second time within a month of regular use after installation.

The chimney should be swept at least twice a year. Where the top outlet or vertical rear flue connector is used it will generally be possible to sweep the chimney through the appliance.

First remove the upper and lower throat plates. Then sweep the chimney ensuring that soot is removed from all horizontal surfaces after sweeping.

In situations where it is not possible to sweep through the appliance the installer will have provided alternative means, such as a soot door. After sweeping the chimney the appliance flue outlet and the flue pipe connecting the stove to the chimney must be cleaned with a flue brush.

After clearing any soot from within the stove, replace the throat plate (see Fig. 2).

Different types of sweep's brushes are available to suit different flueways. For prefabricated insulated chimneys the manufacturers instructions with regard to sweeping should be consulted.

Fig.2 Throat Plate Location

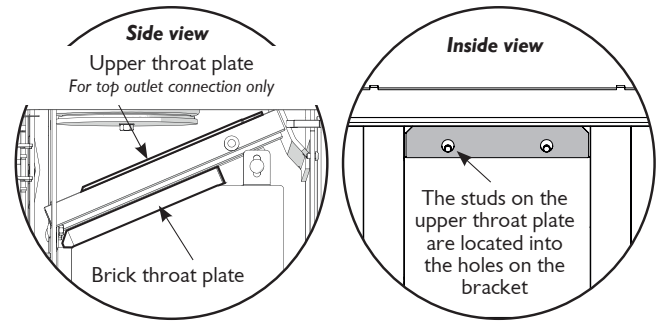

TROUBLE SHOOTING

Fire Will Not Burn

Check that:

- the air inlet is not obstructed in any way,
- chimneys and flueways are clear,
- a suitable fuel is being used,
- there is an adequate air supply into the room,
- If an extractor fan is fitted, that it is not causing lack of flue draft when operating.
- there is sufficient draw in the chimney. Once the chimney is warm a draught reading of at least 1.25 mm (0.05 in.) water gauge (12Pa) should be obtained.

Blackening of Door Glass

Differences in chimney draughts mean that the best settings of the air controls will vary for different installations. A certain amount of experimentation may be required, however the following points should be noted and with a little care should enable the glass to be kept clean in most situations:

- Wet or unseasoned wood, or logs overhanging the front fence will cause the glass to blacken.
- The airwash relies on a supply of heated air to keep the glass clean, therefore, when lighting the stove allow the firebed to become well established before closing the air control. This may also be necessary when re-fuelling the stove.
- When re-fuelling keep the fuel as far back from the front fence as possible, do not try to fit too much fuel into the firebox
- Do not completely close the air control.

It is always more difficult to keep the glass clean when running the stove very slowly for long periods.



If blackening of the glass still occurs check that all flue connections and the blanking plate are well sealed. It is also important that the chimney draw is sufficient and that it is not affected by down-draught. When the chimney is warm a draught reading of at least 1.25 mm (0.05 in.) water gauge (12Pa) should be obtained. Some blackening of the glass may occur below the level of the fuel retainer. This will not obscure the view of the fire or affect its performance.

Fume Emission

Warning Note: Properly installed and operated this appliance will not emit fumes. Occasional fumes from de-ashing and re-fuelling may occur. Persistent fume emission is potentially dangerous and must not be tolerated. If fume emission does persist, then the following immediate actions should be taken:

- a) **Open doors and windows to ventilate the room and then leave the premises.**
- b) **Let the fire out and safely dispose of the fuel from the appliance.**
- c) **Check for flue or chimney blockage, and clean if required.**
- d) **Do not attempt to re-light the fire until cause of fuming has been identified, if necessary seek professional advice.**

The most common cause of fume emission is flueway or chimney blockage. For your own safety these must be kept clean.

Fire blazing out of control

Check that:

- a) The door is tightly closed.
- b) The air control slider is fully closed.
- c) A suitable fuel is being used.
- d) Door seals and air slide are intact.

Chimney Fires

If the chimney is thoroughly and regularly swept, chimney fires should not occur. However, if a chimney fire does occur close the air control, and tightly close the door of the appliance. This should cause the chimney fire to go out in which case the controls should be kept closed until the stove has gone out. The chimney and flueways should then be cleaned. If the chimney fire does not go out when the above action is taken then the fire brigade should be called immediately. After a chimney fire the chimney should be carefully examined for any damage. Expert advice should be sought if necessary.

CO ALARM

Your installer should have fitted a CO alarm in the same room as the

appliance. If the alarm sounds unexpectedly, follow the instructions given under “Warning Note” above.

IF YOU NEED FURTHER HELP

If you need further help with your Charnwood then your Installer will be able to provide the answers to most questions. Your Local Charnwood Premier Dealer has a great deal of experience and will also be able to provide helpful advice. Further help is available from the Charnwood Customer Services department who will be pleased to give advice, if necessary.



UNPACKING THE STOVE

The stove arrives bolted and strapped to its pallet. There must be adequate facilities for unloading and manoeuvring into position. The wrapping is first removed, then the stove released from the pallet by removing 4 pallet bolts using a 10mm spanner. The pallet brackets can now be removed from the stove by tilting it and using a 13mm spanner to remove the bolts. The pallet is intended to be cut up and used for kindling fuel.

HEALTH AND SAFETY PRECAUTIONS

Please take care when installing the stove that the requirements of the Health and Safety at Work Act 1974 are met.

Some types of fire cement are caustic and should not be allowed to come into contact with the skin. In case of contact wash with plenty of water.

If there is a possibility of disturbing any asbestos in the course of installation then please use appropriate protective equipment.

Ideally there should not be an extractor fan fitted in the same room as the appliance. If this situation is unavoidable then specialist advice should be taken to ensure that the extractor fan does not cause the appliance to emit fumes into the room. The external air kit will help with this in some situations. Alternatively, an additional air supply correctly positioned may be necessary. It is essential to carry out a spillage test to ensure that the appliance can operate safely when the extractor fan is operating.

There must be an adequate air supply into the room in which the appliance is installed to provide combustion air. The combustion air supply must be via a permanently open vent. The requirement for minimum free area is partly dependent on the design air permeability of the house. In older properties the air permeability will be above $5.0\text{m}^3/(\text{h}\cdot\text{m}^2)$, but in some modern properties it may be less. The vent must be positioned such that it is not liable to blockage. Minimum areas are given in the following table:

AIR PERMEABILITY $\text{m}^3/(\text{h}\cdot\text{m}^2)$	MINIMUM VENT AREA $\text{cm}^2(\text{in}^2)$	
	C FOUR DUO	C FIVE DUO
>5.0	No requirement	No requirement
<5.0	27.5 (4.3)	27.5 (4.3)

A fixed ducted air supply may be used as an alternative to the traditional method of using a permanent open vent into a room to supply air for combustion.

External air supply kits are available please contact Charnwood for more information. Instruction sheet ref: TIS 120

This stove is capable of intermittent operation, and is not suitable for use in a shared flue system.

In addition to these instructions the requirements of BS.8303 and BSEN 15287-1:2007 must be fulfilled. Local Authority Bylaws and Building Regulations, including those referring to national and European Standards, regarding the installation of Solid Fuel burning appliances, flues and chimneys must also be observed.

CO ALARMS

Building regulations require that whenever a new or replacement fixed solid fuel or wood/biomass appliance is installed in a dwelling a carbon monoxide alarm must be fitted in the same room as the appliance. Further guidance on the installation of the carbon monoxide alarm is available in BS EN 50292:2002 and from the alarm manufacturer's instructions. Provision of an alarm must not be considered a substitute for either installing the appliance correctly or ensuring regular servicing and maintenance of the appliance and chimney system.

SPECIFICATION

SPECIFICATION	C FOUR DUO		C FIVE DUO	
Fuel	Wood logs	Solid fuel	Wood logs	Solid fuel
Rated Heat Output kW (BTU/hr)	5kW	4.3kW	5kW	5kW
Model weight kg (Packed)	83	83	96	96
Emission of CO in combustion products:	0.08	0.10	0.09	0.12
Flue temperature:	235 °C	261 °C	224 °C	234 °C
Energy efficiency:	83.5%	78.4%	84.2%	80.3%
Particles (mg/m^3)	28	36	27	26
Minimum Flue Draught	12Pa	12Pa	12Pa	12Pa
Flue gas Mass Flow g/s	4.0	3.8	4.1	4.0
Hearth Temperature	>100	>100	>100	>100
Hearth Temperature with Stand option	<100	<100	<100	<100
Minimum distance from combustibles mm	SIDE	BACK	SIDE	BACK
	SIDE	BACK	SIDE	BACK
With single wall flue:	550	500	550	500
With insulated flue and heatshield:	450	200	450	200
	500	300	500	300

The outputs in the table are based on a 45 minute re-fuelling cycle burning seasoned hardwood logs. All tests are carried out in accordance with BSEN 13240.



CHIMNEY

In order for the appliance to perform satisfactorily the chimney must give sufficient draw when warm (minimum of 12pa/0.05" wg). The height of the chimney must comply with local building regulation requirements. The internal dimensions of the chimney **MUST NOT BE LESS THAN 125mm (5")**

If an existing chimney is to be used it must be swept and checked, it must be in good condition, free from cracks and blockages, and should not have an excessive cross sectional area. If it was previously used by an open fire then the chimney should be swept one month after installation to clear any soot falls which may have occurred due to the difference in combustion between the stove and the open fire. If you find that the chimney is in poor condition then expert advice should be sought regarding the necessity of having the chimney lined. If it is found necessary to line the chimney then a lining suitable for Solid Fuel must be used.

If there is no existing chimney then a prefabricated block chimney or a twin walled insulated stainless steel flue to BSEN 15287-1:2007 can be used either internally or externally. These chimneys must be fitted in accordance with the manufacturers instructions and Building Regulations.

Single wall flue pipe is suitable for connecting the stove to the chimney but is not suitable for using for the complete chimney. If it is found that there is excessive draw in the chimney then a draught stabiliser should be fitted.

It is important that there is sufficient draw in the chimney and that the chimney does not suffer from down-draught. When the chimney is warm the draw should be not less than 1.25mm (0.05") water gauge (12 Pa). If in doubt about the chimney seek expert advice.

HEARTH AND FIRE SURROUND

The stove must stand on a fireproof hearth and must not be situated closer than the minimum distance from combustible materials (see specification table) to the sides or rear above hearth level unless adequately fireproofed in accordance with local building regulations. The hearth must be of fireproof material and at least 12mm (1/2in.) thick if the stove is attached to a stove stand or high legs. If the stove stand or high leg option is fitted then the hearth temperature will not exceed 100°C and so a 12mm thick fireproof hearth is adequate. If the standard leg option is used then the hearth temperature can exceed 100°C and therefore a 12mm thick hearth is not suitable and a constructional fireproof hearth is required. The positioning of the

stove and the size of the hearth are governed by building regulations for Class 1 appliances. These building regulations state that the hearth must extend in front of the stove by at least 225mm (9 in.) and to the sides of the stove by at least 150mm (6 in.). When the fire door is open, it extends beyond the flat front of the stove by 365mm (C Four duo) and 436mm (C Five Duo).

If in doubt as to the positioning of the stove, expert advice should be sought either from the supplier or the local building inspector. The fireplace must allow good circulation of air around the appliance to ensure that maximum heat is transferred to the room and also to prevent the fireplace from overheating. A gap of 150mm (6") each side and 300mm (12") above the appliance should give sufficient air circulation. If a wooden mantelpiece or beam is used in the fireplace it should be a minimum of 460mm (18"), and preferably 600mm (24") from the appliance. In some situations it may be necessary to shield the beam or mantelpiece to protect it.

The appliance should be installed on a floor with adequate load-bearing capacity. If an existing construction does not meet this requirement then please take suitable measures to achieve this. (e.g. load distributing plate.)

CONNECTIONS TO FLUES

The C Five and C Four Duo must be connected to the flue using flue pipe of 125mm (5") diameter.

If using twin wall flue, the flue collar must be shielded to protect exposed combustible material. This can be done with a shielded starter length of flue.

The flue spigot can be shielded with starter length flue see fig. 3

Fig. 3 Shielding the flue spigot

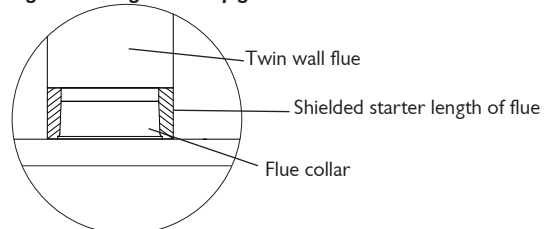

There are several ways of connecting the stove to the flue. These are illustrated in Figs. 5 to 8.

If the top flue connection or optional vertical rear flue connector is used then the chimney may be swept through the appliance.

Horizontal lengths of flue must be kept to a minimum and should not be more in length than the flue diameter.



The stove comes with the blanking plate (fig. 9) fitted to the top flue outlet. The seal for the top outlet is a 155mm dia ring of rope seal. The seal for the rear outlet is a length of adhesive backed fibre webbing supplied with instructions ref: TIS093. This is applied to the flue collar or the Vertical Rear Flue adapter for rear outlet installations. For top outlet installations, the blanking plate must be removed, have the webbing fitted to its sealing face, and fitted to the rear flue outlet. Ensure that the fold on the clamping plate is in line with the lugs on the firebox as shown in Fig 9. Ensure that the clamping plate does not prevent the throat plate from seating correctly. All flue connections must be well sealed.

SOOT DOORS

It is possible to pass a 16 inch diameter sweeps brush through the appliance but in most back outlet installations it will be necessary to have a soot door to enable the chimney to be swept. The optional vertical rear flue connector does allow the chimney to be swept through the stove. Soot doors may either be in the actual brickwork of the chimney or in the register plate. Various positions of soot doors are shown in Figs. 5 to 8.

PRE LIGHTING CHECK

Ensure that the throat plate and upper baffle is fitted in the roof of the appliance. For location and positioning see Fig. 2.

Check that the front fence is fitted correctly and that the door closes properly.

COMMISSIONING

On completion of the installation allow a suitable period of time for the fire cement and mortar to dry out before lighting the fire. Make a layer of ash or sand on the base of the stove before lighting. Check to ensure that smoke and fumes are taken from the appliance up the chimney and emitted safely. Also check all joints and seals. On completion of the installation and commissioning please leave the operating instructions with the customer and advise them on the use of the appliance.

Fig. 5 Vertical Register Plate With Bricked Up Fireplace

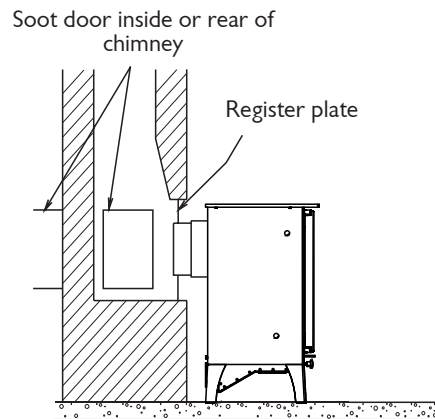

Fig. 6 Horizontal Register Plate With Rear Flue Connection

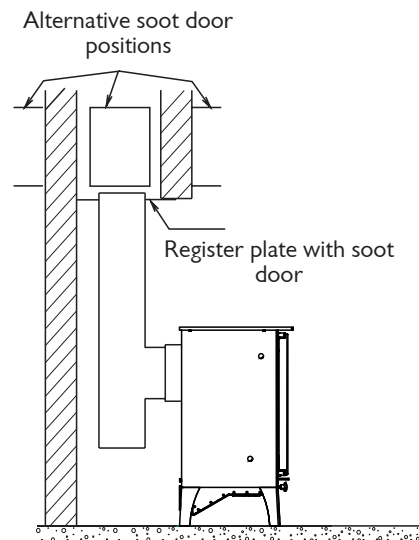

Fig. 7 Horizontal Register Plate With Top Flue Connection

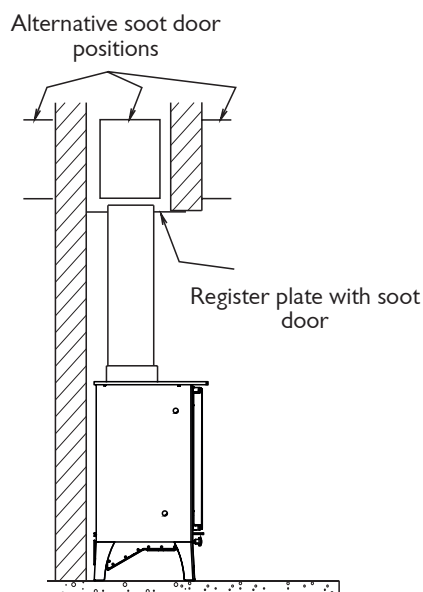
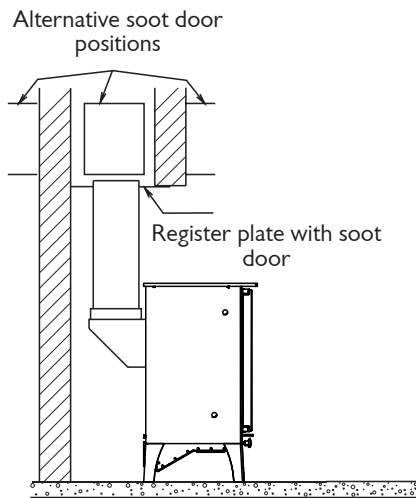



Fig. 8 Horizontal Register Plate With Optional Vertical Rear Flue Connector



CAA AND SMOKE CONTROL

Under the Clean Air Act local authorities may declare the whole or part of the district of the authority to be a smoke control area. It is an offence to emit smoke from a chimney of a building, from a furnace or from any fixed boiler if located in a designated smoke control area. It is also an offence to acquire an “unauthorised fuel” for use within a smoke control area unless it is used in an “exempt” appliance (“exempted” from the controls which generally apply in the smoke control area).

In England appliances are exempted by publication on a list by the Secretary of State in accordance with changes made to sections 20 and 21 of the Clean Air Act 1993 by section 15 of the Deregulation Act 2015. Similarly in Scotland appliances are exempted by publication on a list by Scottish Ministers under section 50 of the Regulatory Reform (Scotland) Act 2014.

In Wales and Northern Ireland these are authorised by regulations made by Welsh Ministers and by the Department of the Environment respectively.

The C Four Duo and C Five Duo have been recommended as suitable for use in smoke control areas when burning wood logs. This is conditional upon following the wood burning instructions precisely. Suitable Authorised fuels can also be used in the appliances in Smoke Control Areas (see Authorised fuel list <https://smokecontrol.defra.gov.uk/fuels.php>)

Further information on the requirements of the Clean Air Act can be found here: <http://smokecontrol.defra.gov.uk> . Your local authority is responsible for implementing the Clean Air Act 1993 including

designation and supervision of smoke control areas and you can contact them for details of Clean Air Act requirements

The C-Four Duo has been recommended as suitable for use in smoke control areas when burning wood logs. The C-Four Duo is factory fitted with a permanent stop to prevent full closure of the air controls.

The C Five Duo Stove has been recommended as suitable for use in smoke control areas when burning wood logs. The C Five Duo Stove must be fitted with a permanent stop to prevent closure of the secondary air control slide plate beyond 6mm and the tertiary air slide plate beyond 6mm open.

Fig. 9. Flue Blanking Plate.

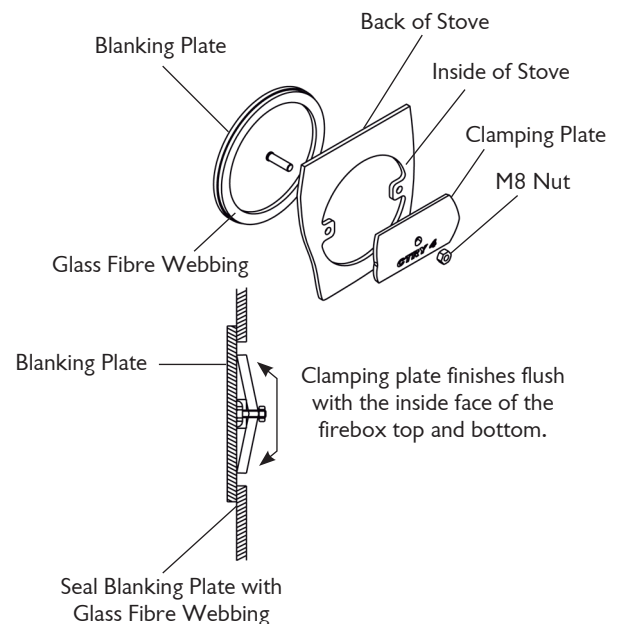

COOKING PLATE

A Cooking plate attachment is available for the C Five and C Four Duo

010/AP150S - 5 inch kit used on the C Five and C Four Duo

The kit comprises of a cooking plate and four trivets and can only be fitted to the stove if a rear flue connection is made.

C FOUR DUO DIMENSIONS

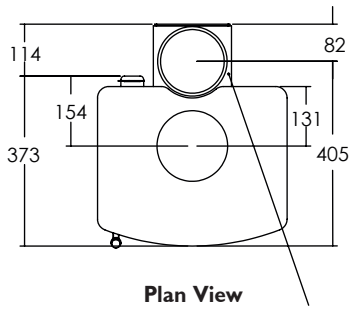

Plan View

Optional Vertical Rear Flue Adapter

140 i/d to suit 125mm (5") flue pipe

Standard Model

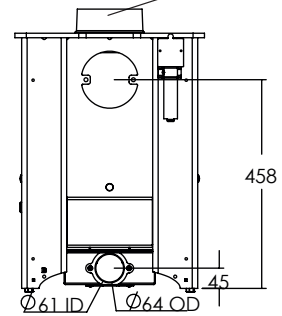
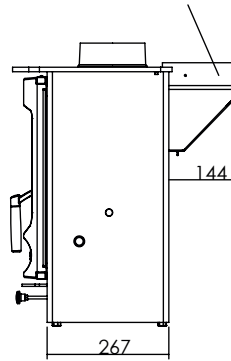
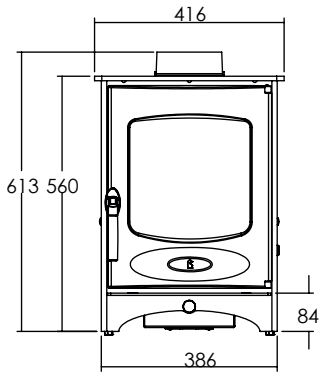

Store Stand

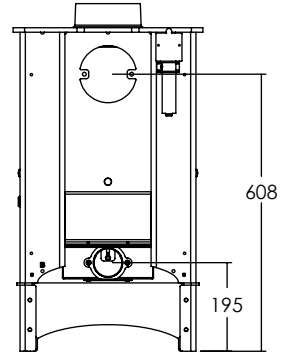
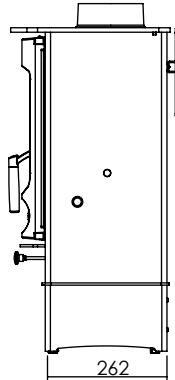
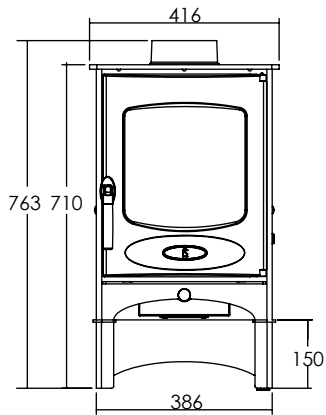

High Leg

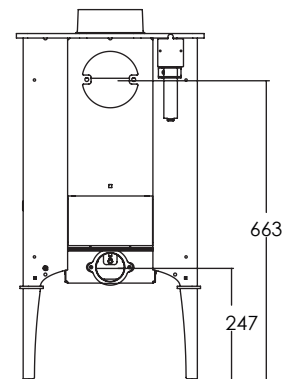
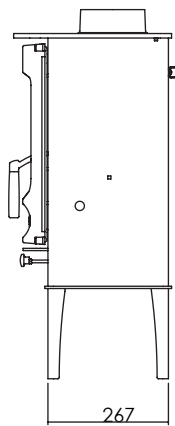
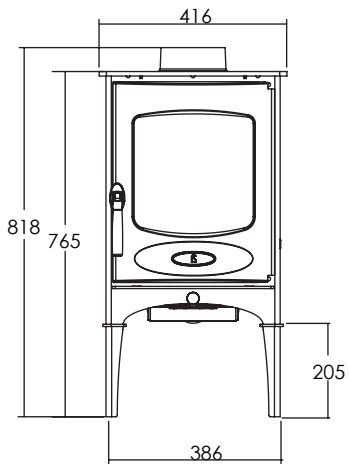

Front

Side

Rear

C FIVE DUO DIMENSIONS

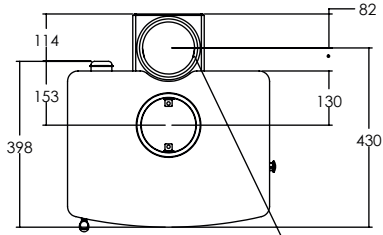

Plan View

Optional Vertical Rear Flue Adapter

140 i/d to suit 125mm (5") flue pipe

Standard Model

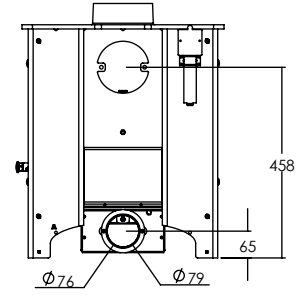
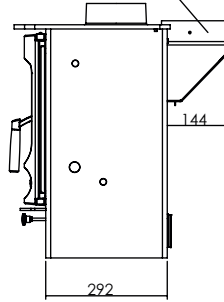
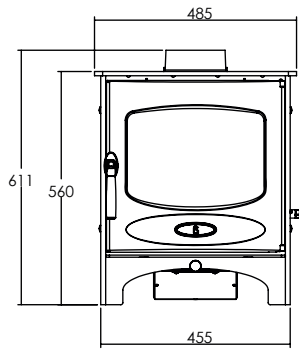

Store Stand

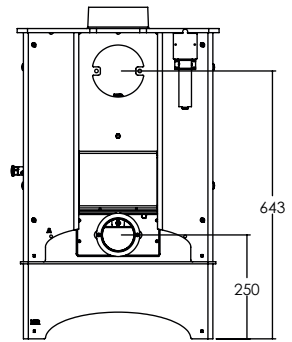
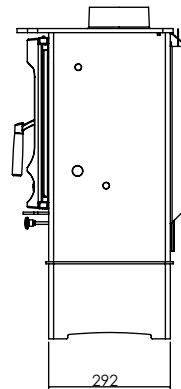
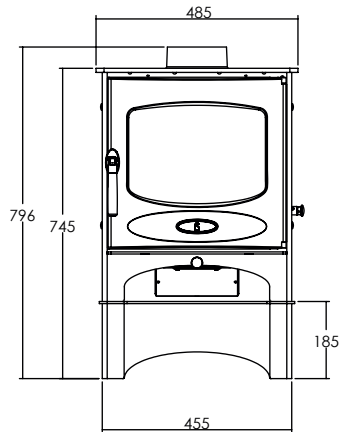

High Leg

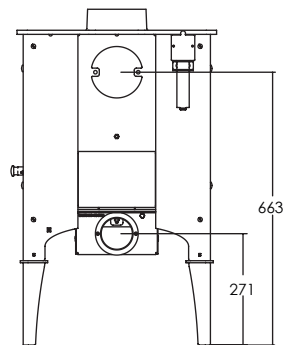
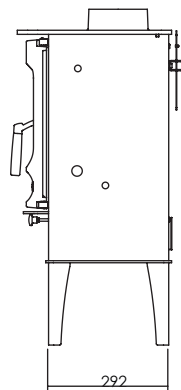
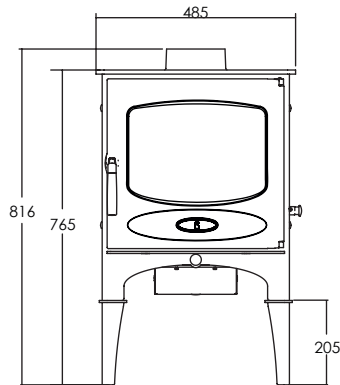

Front

Side

Rear

Charnwood C-Four Duo Parts List

Issue E

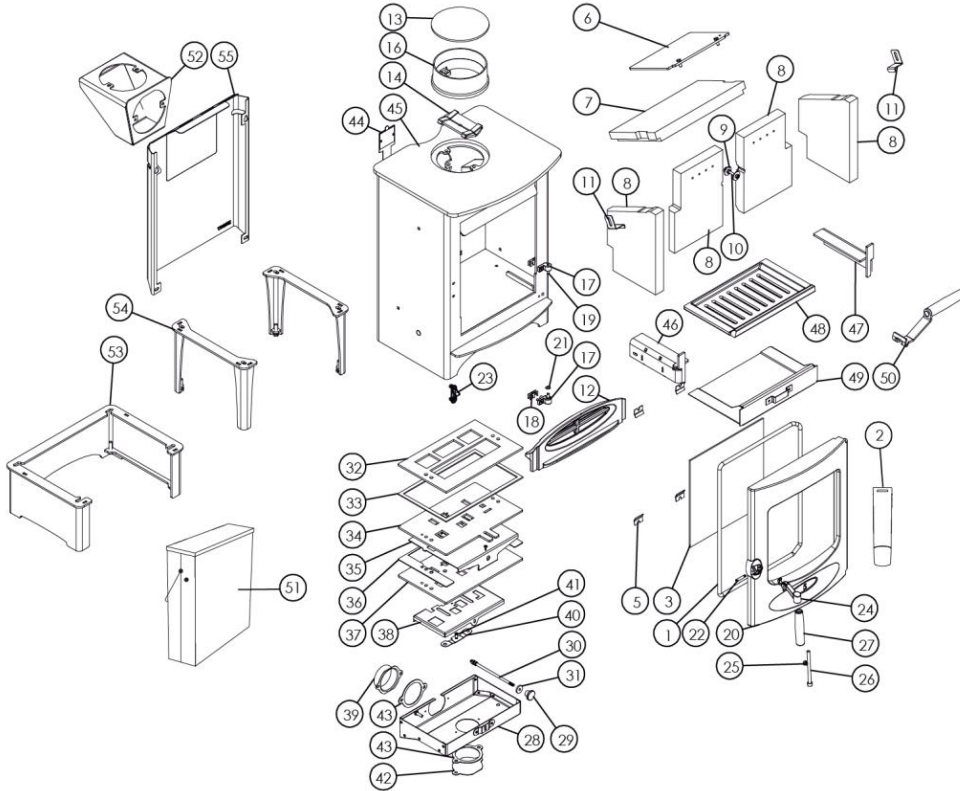

Item	Part No.	Description	Item	Part No.	Description
1*	008/BR038	Rope Door Seal	29	008/AY37	Air Control Knob
2*	008/TH085	Door Seal Adhesive	30	004/BR016	Control Rod
3	006/PV19	Glass (Inc Seal)	31	008/BR052	Felt Washer
4*	008/PV55	Glass Seal	32	008/BRM109	Air Control Gasket
5	004/KV23	Glass Retainer	33	008/BRM108	Air Box Gasket
6	010/NRM032	Upper Throat Plate	34	010/BRM111	Air Slider Base Plate
7	011/BRM031	Brick Throat Plate	35	004/BRM113	Solid Fuel Slider
8	011/BRM029S	Set of Firebricks	36	004/BRM112	Airslide Guide
9	010/ER036	Brick Retaining Washer	37	010/BRM130	Air Control Lower Plate Assembly
10	008/FFB127	M6x45 Coach Bolt	38	004/BRM115	Main Airslide
11	004/XV30	Brick Retaining Bracket	39	004/BR053	Air Inlet Spigot
12	002/BR017	Fuel Retainer	40	004/BR015	Clicker Retainer Plate
13	012/PV09	Blanking Plate	41	008/ES36/01	Brass Ball Catch
14	010/EY51	Clamping Plate	42	004/BR054	Coverplate
15*	008/EY38	Flue Fixing Rope Seal	43	008/BR044	Blanking Plate Gasket
16#	002/PV12B	Flue Collar	44	012/BRM011	Serial No. Label
17	002/BR020	Hinge	45#	001/BRM010	Firebox
18	004/BR021	Hinge Shim	46	010/BRM026	Left Side Plate
19	008/ST068/2	Hinge Pin Set	47	010/BRM027	Right Side Plate
20#	002/BR001/A	Door Assembly	48	002/BRM022	Grate
21	008/FFW026	1/4 Heavy Brass Washer	49	004/BRM017	Ashpan
22	004/BR014	Handle Pivot Pin	50	012/BV20/A	Ashpan Tool
23	004/BR084	Door Latch	51*	010/EW51	Ash Carrier (Optional Extra)
24	002/BR087	Handle Casting	52#	010/BU034	Vert Rear Flue Adaptor (Opt'l Extra)
25	008/PV43	Spring Washer (Thackery Type)	53#	010/BR050	Store Stand (Optional Extra)
26	008/FFB007	M8 x 100mm Allen Head Bolt	54#	010/BR051S	High Legs (Optional Extra)
27	008/BR013	Wooden Handle	55#	010/BR057	Heat Shield (Optional Extra)
28	004/BRM040	Airbox Cover			

* These items are not shown on the drawing.
Please specify colour when ordering.

To obtain spare parts please contact your local stockist giving Model, Part No. and Description. In case of difficulty contact the manufacturer at the address shown. This drawing is for identification purposes only.

Charnwood C-Five Duo Parts List

Issue D

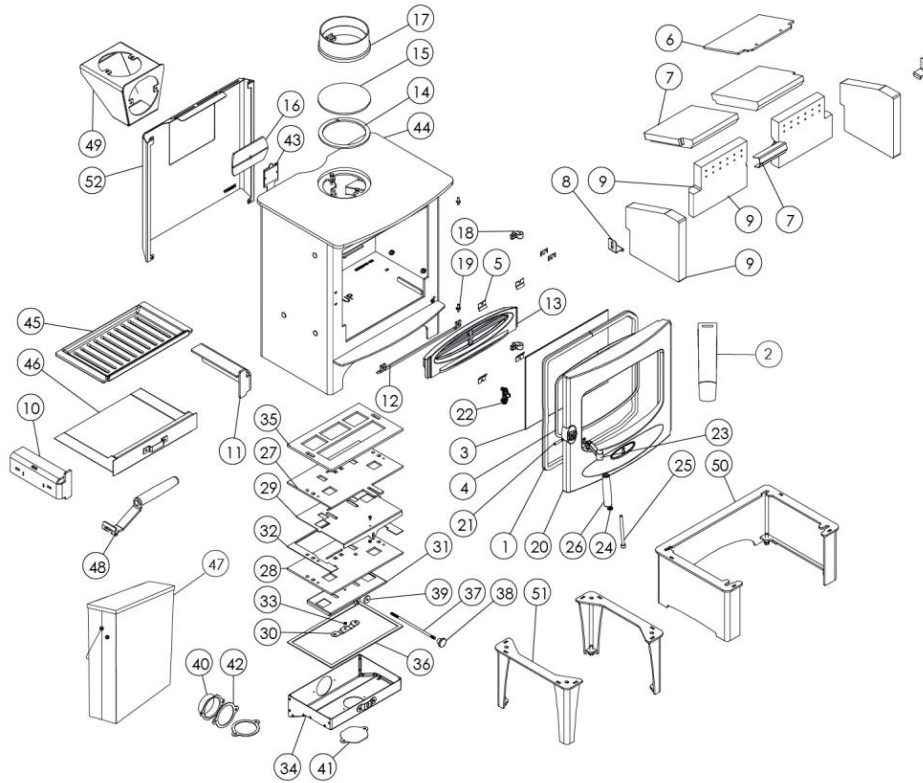

Item	Part No.	Description	Item	Part No.	Description
1	008/NR039	18mm Rope Door Seal (V2 Door)	27	010/NRM111	Air Control Top Slider Plate
2*	008/TH085	Door Seal Adhesive	28	010/NRM131	Air Control Base Plate
3	006/NR019	Glass	29	004/NRM113	Solid Fuel Slider
4	008/NR044	Glass Seal	30	004/BR015	Clicker Retainer Plate
5	004/KV23	Glass Retainer	31	004/NRM115	Main Slider
6	010/NRM032	Upper Throat Plate	32	004/NRM112	U \checkmark Slider Spacer
7	011/NRM031S	Set of Throat Plate Bricks Inc. Bracket	33	008/ES36/01	Brass Ball Catch
8	004/XV30	Brick Bracket	34	004/NRM040	Air Box
9	011/NRM029S	Set of Firebricks	35	008/NRM110	Air Control Gasket
10	010/NRM012	L.H. Brick and Fence Support	36	008/NRM116	Airbox Gasket
11	010/NRM013	R.H. Brick and Fence Support	37	004/ER016	Control Rod
12	010/NR018	Ash Deflector	38	008/AY37	Air Control Knob - Matt Black Knob
13	002/NR017	Fuel Retainer	39	008/BR052	Felt Washer
14	008/EY38	Flue Fixing Rope Seal	40	004/BR053	Air Inlet Spigot
15	012/PV09	Blanking Plate	41	004/BR054	Coverplate
16	010/EY51	Clamping Plate	42	008/BR044	Duct Gasket
17#	002/PV12B	Flue Collar	43	012/NRM011	Serial No. Label
18	002/BR020	Hinge Casting	44#	001/NRM010	Firebox
19	008/ST068/2	Hinge Pin Set 5mm x 25mm	45	002/NRM022	Grate
20#	002/NR001/A	Door Assembly	46	004/NRM017	Ashpan
21	004/BR014	Handle Pivot Pin	47*	010/EW51	Ash Carrier (Optional Extra)
22	004/BR084	Door Latch	48	012/BV20/A	Ashpan Tool
23	002/BR087	Handle Casting	49#	010/BU034	Vertical Rear Flue Adapter (Opt'l Extra)
24	008/PV43	Thackery Washer	50#	010/NR050	Store Stand (Optional Extra)
25	008/FFB007	M8 x 100 Allen Hd Bolt	51#	010/ER051S	High Legs (Optional Extra)
26	008/BR013	Wooden Handle	52#	010/NR057	Heat Shield (Optional Extra)

* These items are not shown on the drawing.
Please specify colour when ordering.

To obtain spare parts please contact your local stockist giving Model, Part No. and Description. In case of difficulty contact the manufacturer at the address shown. This drawing is for identification purposes only.



charnwood



AJ WELLS & SONS LTD

Bishops Way, Newport, Isle Of Wight PO30 5WS, United Kingdom
A Division of A.J.Wells & Sons Limited Registered In England No. 03809371



EN16510-1:2022 / EN16510-2-1:2022

ROOMHEATER

Model:	C Four Duo		C Five Duo	
EC Certificate of conformity no:	BRM11-CPD-2022		NRM11-CPD-2022	
Fuel type:	WOOD LOGS	SOLID FUEL	WOOD LOGS	SOLID FUEL
Rated space heating thermal output:	5kW	4.3kW	5kW	5kW
Emission of CO in combustion products:	0.08	0.10	0.09	0.12
Mean flue gas temperature:	235 °C	261 °C	224 °C	234 °C
Energy efficiency:	83.5%	78.4%	84.2%	80.3%
Particles (mg/m ³ _n)	28	36	27	26
Minimum distance to combustible materials Single wall flue: Side: Rear:	550 500	550 500	500 500	500 500
Insulated flue & heatshield: Side: Rear:	450 200	450 200	500 300	500 300
Minimum distance to combustible materials in corner placement Insulated flue & heatshield: Rear corners: Centre of flue:	400 629	400 629	425 688	425 688
Fulfilled requirements: BStV of the City of Munich and the City of Regensburg FBStVO of the City of Aachen and the City of Düsseldorf 1.and 2. level of 1. BImSchV of Germany	✓	✓	✓	✓

All product related data available here:

<https://www.charnwood.com/conformance-documentation>

your premier dealer

charnwood BISHOPS WAY, NEWPORT, ISLE OF WIGHT PO30 5WS, UNITED KINGDOM
TEL. +44 (0) 1983 537777 • FAX. +44 (0) 1983 537788 • WWW.CHARNWOOD.COM

A Division of A.J. Wells & Sons Limited Registered in England No. 03809371