



charnwood
BAY
5/5GT/5VL

Operating & Installation Instructions

CONTENTS

OPERATING INSTRUCTIONS

Quick Guide	4
General	5
Fuel	5
Door Operation	5
Fan Operation	5
Ash Clearance	6
Riddling Grate	6
Controlling the Fire	6
Lighting	7
Refuelling	8
Ash Pan Removal	8
Reduced Burning	8
Cleaning and Maintenance	8
Throat Plate and Flueway Cleaning	9
Chimney Sweeping	9
CO Alarm	9
Troubleshooting	10
If you need further help	10

INSTALLATION INSTRUCTIONS

Unpacking the Stove	11
Health and Safety Precautions	11
CO Alarms	11
Specifications	11
Chimney	11
Hearth and Fire Surround	12
Preparation of Fireplace	13
Connecting the Fans	13
Air Supply	13
Fitting the Stove and Flue Pipe	14-16
Fitting the Optional Base Assembly	17
Pre-lighting Check	17
Commissioning	17
CAA & Smoke Control	17-18
Dimensions	19-21
Parts Lists	22-24
Certification	25-26

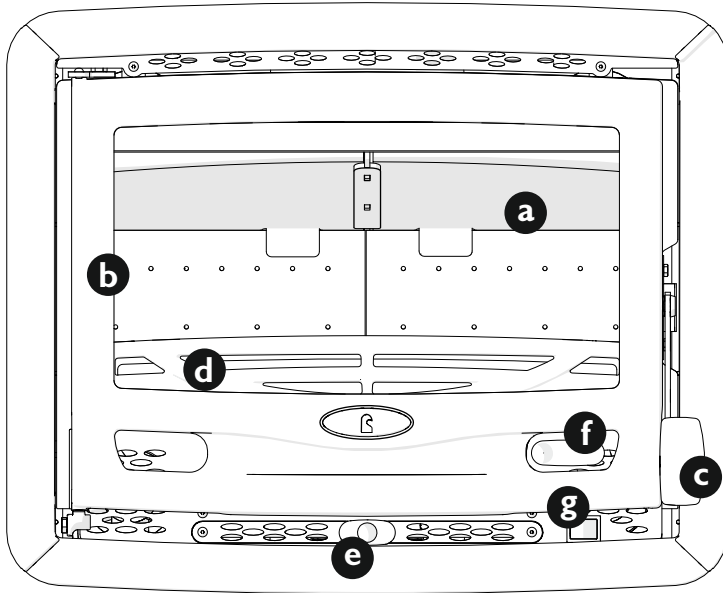

Bay 5GT

- a Throat plate**
Improves efficiency of stove by slowing down flue gases. See page 9 for how to remove.
- b Door**
Keep closed when stove is in use.
- c Door handle**
Pull up to open.
- d Fuel retainer**
Ensure fuel does not protrude beyond retainer.
- Air control**
- e** Pull out/slide left for higher output. See page 6 for more detail.
- Riddler handle (Bay 5GT only)**
- f** Pull handle in and out to riddle. See page 6 for more detail.
- g Fan switch (Bay 5GT only)**
The fan turns on automatically. See page 5 for more detail.

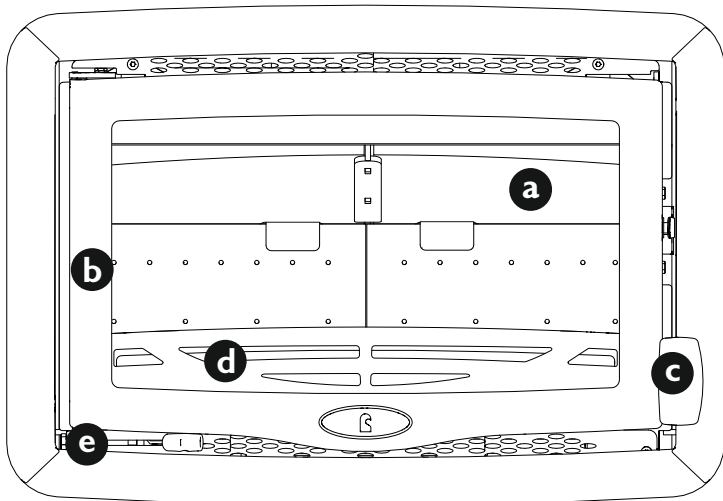

Bay 5

Suitable fuels for your Charnwood:

This stove is designed to burn only wood.

Unsuitable fuels:

- Smokeless fuels
- Petroleum coke
- Liquid fuel
- Household waste
- Coal singles
- Wet or unseasoned wood

p5

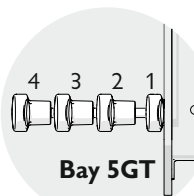

Bay 5GT

Air control

1. Slumber
2. Medium output
3. High output
4. Boost

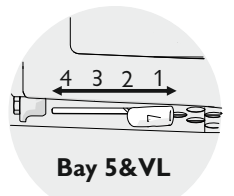

Bay 5&VL

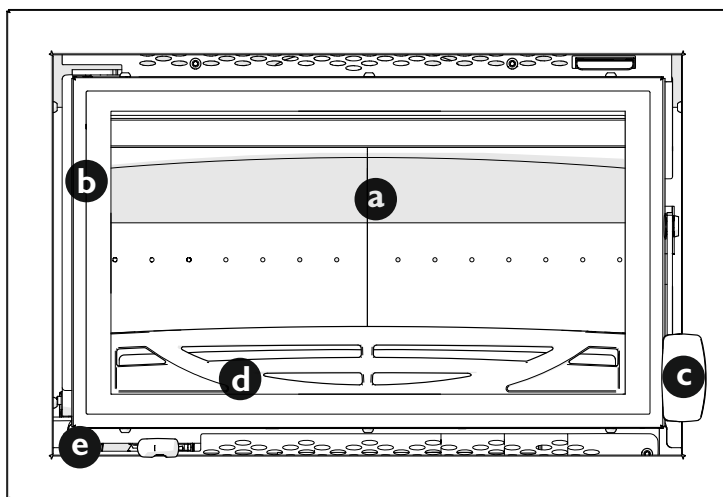

Bay VL

MAINTENANCE AND CLEANING

- Glass** *Wipe with damp, lint free cloth. Any stubborn deposits on the glass may be removed with a proprietary stove glass cleaner or ceramic hob cleaner*
- Enamel Frame (Bay VL)** *To clean enamel surfaces simply wipe over with a dry cloth or soft brush. Abrasive pads and scouring cleaners must not be used as these will damage the finish. Care should be taken not to knock the enamel with hard objects as it will chip.*
- Throat plate** *Take down once a month and clean. Sweep sooty deposits into fire*
- Ash pan (Bay 5GT)** *Ash pan is removed using tool provided. Empty ash pan before ash comes into contact with underside of grate*
- Chimney** *Have chimney swept twice a year. Chimney can be swept through stove*
- Servicing** *Stove should be serviced by a professional at least once a year*

GENERAL

Before lighting the stove, check with the installer that the work and checks described in the Installation Instructions have been carried out correctly and that the chimney has been swept, is sound and free from any obstructions. The stove is not suitable for use in a shared flue system.

Remember that the stove will be hot and that it is made from hard materials – ensure that you have good balance before operating the fire. Do not use an aerosol spray on or near the stove when it is alight. There is a risk of explosion or flash ignition of the spray.

When using the stove in situations where children, aged and/or infirm persons are present a fireguard must be used to prevent accidental contact with the stove. The fireguard should be manufactured in accordance with BS 8423:2002.

The stove is suitable for intermittent operation.

FUEL

Only dry, well seasoned wood should be burnt on this appliance as burning wet, unseasoned wood will give rise to heavy tar deposits in the stove, on the glass and within the chimney. For the same reason hard woods (such as Ash, Beech and Oak) are better than soft woods (such as Pine and Spruce). Burning wet, unseasoned wood will also result in considerably reduced outputs. The wood should be cut and split and then left to season in a well ventilated dry place for at least one year, but preferably two years, before use and should have a moisture content of less than 20%. Logs should be no more than 480mm long, and 75mm wide.

PETROLEUM COKE IS NOT SUITABLE FOR USE ON THIS APPLIANCE. ITS USE WILL INVALIDATE THE GUARANTEE.

This stove is not designed to burn household waste. For advice on other fuels, please contact Charnwood.

This appliance has been approved by HETAS as an intermittent operating appliance for burning dry, seasoned wood logs only. HETAS approval does not cover the use of other fuels, either alone or mixed with wood logs, nor does it cover the instructions for the use of other fuels.

DOOR OPERATION

The door handle has been carefully designed so that in normal use it may be operated using bare hands. However, if you need to open the doors when the fire is running at maximum, then the use of the glove provided may be required.

Fig. 1 Stove controls

BAY 5 & BAY VL

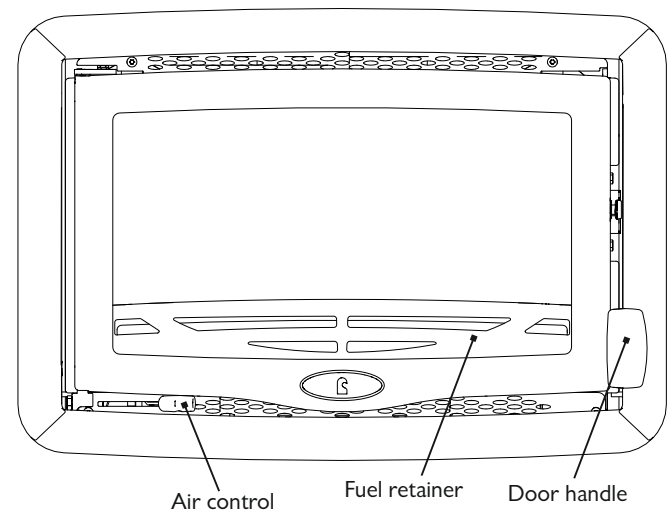

BAY 5GT

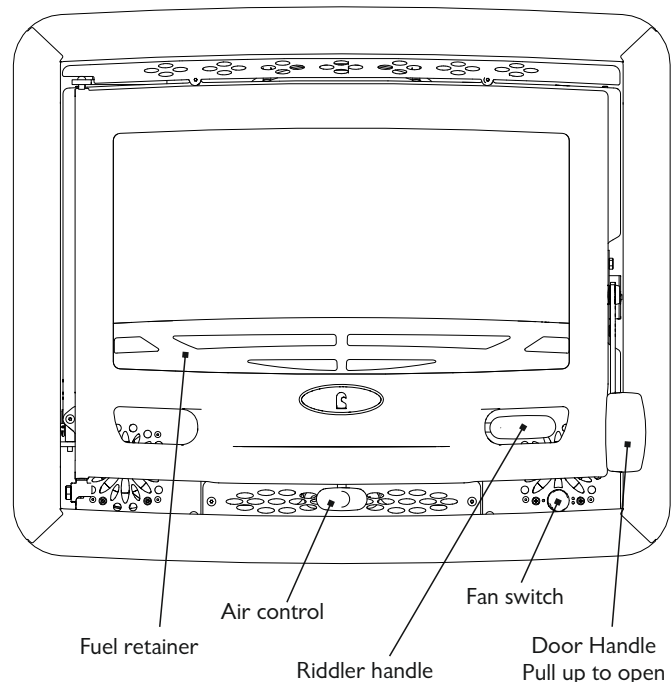

Take care not to touch the doors as they will be hot when the fire is burning. Pull the door handle up to open, and push down to close.

The stove should be run with the door shut.

FAN OPERATION

The Bay 5GT has a convection fan for effective heat distribution to the room. There is a thermal cut out linked into the fan control. This means the fan will not operate until the stove warms up, and will cut out automatically once the stove cools down again. The fan is turned on and off at the mains supply. The fans can be turned off, or set to a higher speed, using the switch at the base of the stove.

ASH CLEARANCE

For optimum wood burning, it is important to leave a layer of ash, around 1cm thick, on the base of the stove. If the ash is becoming too deep, the appliance should be riddled (Bay 5GT) or the top layer of ash cleared using the scoop provided (Bay 5 & Bay VL).

For advice on how and when to empty the ashpan (Bay 5GT), see p8.

RIDDLING GRATE (BAY 5GT)

The Charnwood Bay 5GT is fitted with a riddling grate to enable wood to be burned and ash to be cleared. The grate bars can be rotated to the vertical position to clear an excessive build up of ash.

To riddle the appliance, use the gloves provided and pull the riddler handle rapidly in and out several times (see Fig. 2). For effective wood burning, ash should be allowed to build up and riddling should only be carried out once or twice a week.

Fig. 2 Riddling

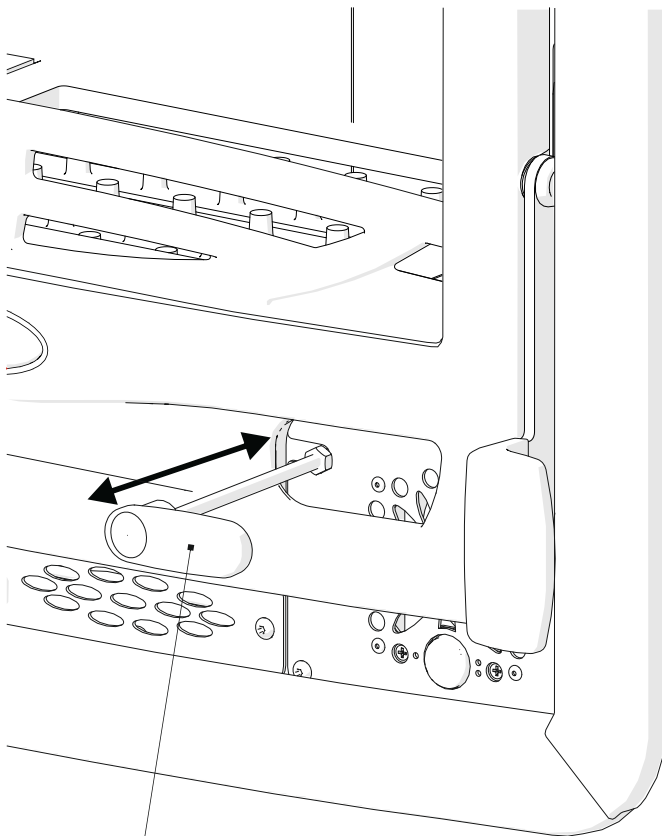

Move handle back and forth to riddle appliance

Fig. 3 Air control

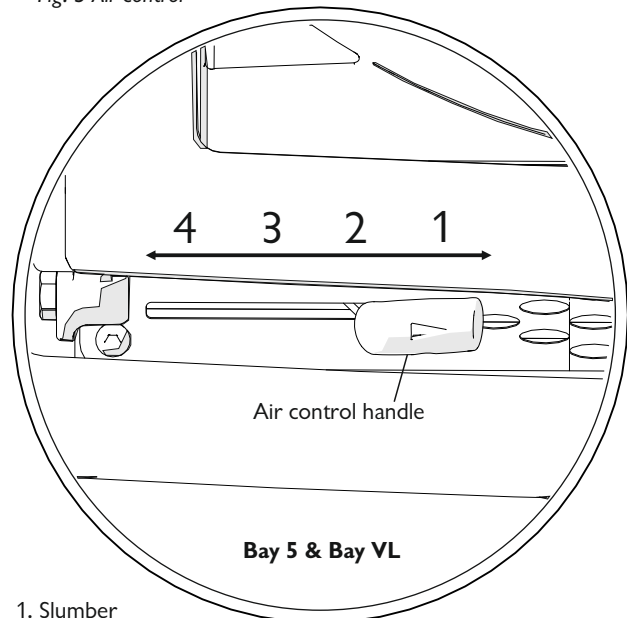

1. Slumber
2. Medium Output
3. High Output
4. Boost

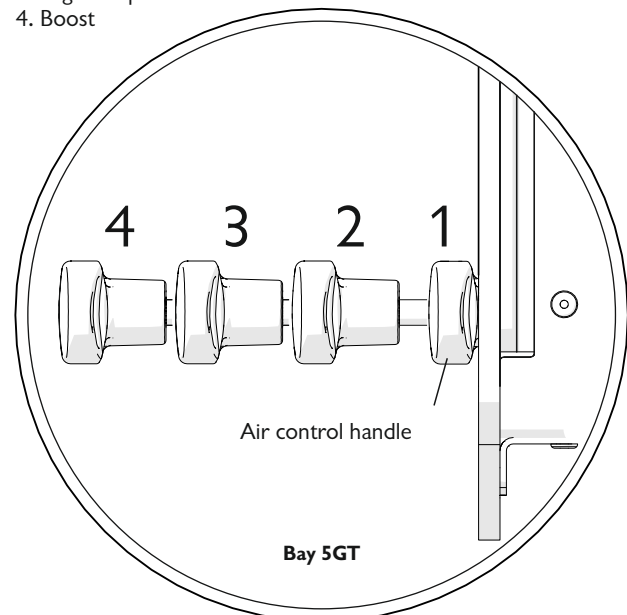

CONTROLLING THE FIRE

The rate of burning and hence the output is controlled by the air control (see Fig. 3).

Open the air control fully when lighting or when rapid burning is required. It should not be left fully open for long periods as this can cause over-firing or excessive smoke production. For high output move the air control to the 'High Output' position or for low burning to the fully closed position.

When the fire is burning normally the air control gives enough airwash to keep the glass clean. However, it will not always be possible to keep the glass clean with the air control fully closed.

LIGHTING

On initial lighting, the stove may smoke and give off an odour as the silicon paint with which the firebox is painted reacts to the heat. This is normal and will cease after a short time, but meanwhile the room should be kept well ventilated. At first only light a small fire and burn it slowly for two hours to allow any residual moisture in the chimney to evaporate.

Fig. 4 Initial firing

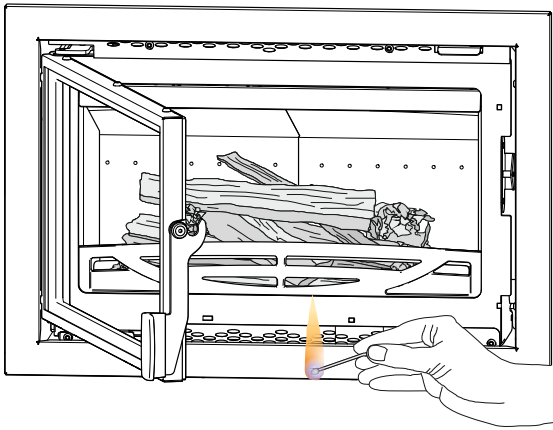

Light the stove using dry kindling wood and paper or fire lighters. It is recommended that you use approximately 1kg to 1.2kg of kindling. Put the paper, or fire lighters, and kindling in the firebox and cover with a few small dry logs. Open the air control fully (see Fig. 3). Light the paper or fire lighters. The door may be left cracked open for a few minutes to assist the combustion and heat up the firebox more quickly.

Fig. 5 Building up the fire

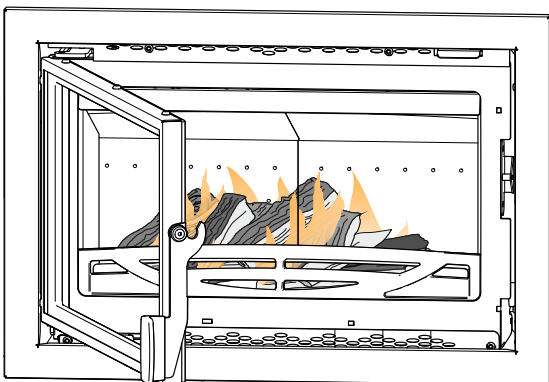

When the kindling wood is well alight add a few more small logs and close the door, but leave the air control fully open. When the flames are established around the smaller logs, load the stove with larger logs to the required fuel load. Logs should be no more than 75mm in diameter and 480mm long. Close the door. Maintain the air control at maximum at this stage.

Fig. 6 Adding larger logs

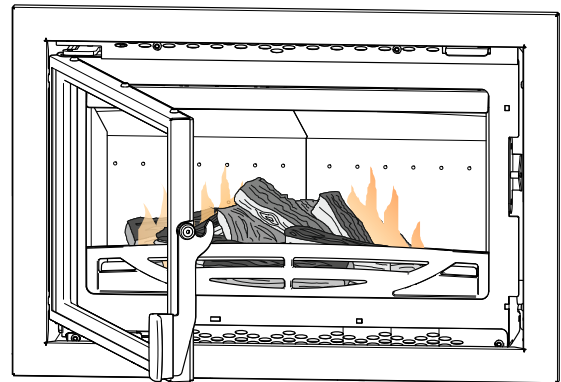

Once long flames appear over the fire, reduce the air control to the 'high output' setting. Once the fire is well established - with each log alight at the top - the air setting can be reduced again, depending on the type of fire required. If at any stage the flames start to go out or the glass begins to discolour, a higher setting is required. To achieve this, open the air control to re-establish a consistent burn.

Fig. 7 Fire well underway

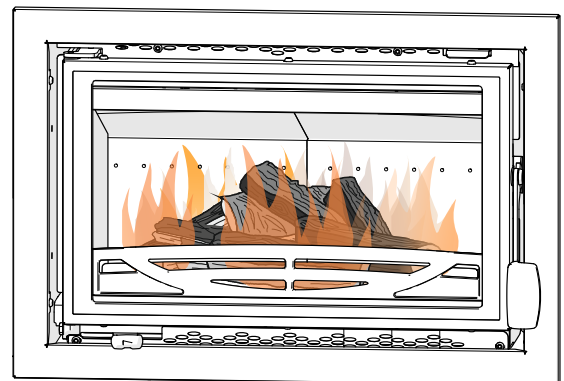

Once the fire is up to temperature the airwash system will begin to work, so allow the fire to become hot before adjusting the air control to the required setting. During the lighting period, do not leave the stove unattended. Do not leave the door open except as directed above to avoid excessive smoke.

When relighting the stove, leave the ash on the base unless it is becoming too deep, in which case some of it may be removed.

REFUELLING

Keep the firebox well filled but do not allow fuel to spill over the top of the fuel retainer.

Logs should be evenly distributed, filling the firebed to give the most pleasing flame pattern. The air control must be fully opened after refuelling until the flames are established above the fire. It is best to refuel on to a hot bed of ash. If at this point the fire starts to die, the door must be cracked open until the fire is revived. If the fire has started to die down before refuelling, then more kindling wood must be added, the air control opened fully and the door cracked open to re-establish the firebed **before** adding larger logs (see suitable log sizes in Specification). This will avoid excessive smoke emission.

Care should be taken that wood does not project over the fuel retainer or damage to the glass may be caused when the door is closed. It can also cause the glass blackening of the glass. Maximum filling height is such that logs cannot fall from the fire when the door is opened. In smoke controlled areas do not fill the stove above the level of the air holes in the back bricks, as overloading can cause excess smoke. Liquid fuels are not to be used on this appliance.

ASH PAN REMOVAL

The ashpan (Bay 5GT) should be emptied regularly before it becomes too full. Never allow the ash to accumulate in the ashpan so that it comes in contact with the underside of the grate as this will seriously damage the grate bars. The ashpan is handled using the tool and gloves provided. Care should be taken to ensure that ash is cool before emptying it into plastic liners or bins.

To make ash removal easier there is a special Charnwood ash carrier available. This may be purchased from your supplier or, in case of difficulty, directly from Charnwood.

REDUCED BURNING

For reduced burning the fire door must be closed.

When burning wood in areas that are not smoke controlled, load some large logs on the fire and allow to burn for half an hour before closing the air control (this will help to reduce tar deposits in the chimney). Some experimentation may be necessary to find the setting most suitable for the type of fuel being used and the draw on the chimney.

To revive the fire, empty the ashpan, riddle the fire, and open the air control to maximum. When the fire is burning well load on more fuel as necessary and adjust the air control to the desired setting.

CLEANING AND MAINTENANCE

Cleaning

The Bay VL is finished with vitreous enamel to clean the surfaces simply wipe over with a dry cloth or soft brush when the appliance is cold. Abrasive pads and scouring cleaners must not be used as these will damage the finish. Care should be taken not to knock the enamel with hard objects as it will chip. The Bay 5 and Bay 5GT are finished with high temperature paint. Should re-painting become necessary, high temperature paints are available from your supplier or from stove shops, or in case of difficulty, directly from Charnwood.

Cleaning the Glass

The glass in the door is a special ceramic glass which is able to withstand high temperatures. Most deposits on the glass may be burnt off simply by running the fire at a fast rate for a few minutes. If it becomes necessary to clean the glass then open the door and allow it to cool. Clean the glass using a damp cloth and then wiping over with a dry cloth. Any stubborn deposits on the glass may be removed with a proprietary stove glass cleaner or ceramic hob cleaner. Aerosol spray cleaners must not be used near the appliance whilst it is under fire.

Do not use abrasive cleaners or pads as these can scratch the surface which will weaken the glass and cause premature failure.

When Not in Use

If the fire is going to be out of use for a long period (for instance in the summer) then to prevent condensation, and hence corrosion, the air control should be left fully open and the fire door left ajar. It is also advisable to sweep the chimney and clean out the fire. Spraying the inside of the door and firebox with a light oil, such as WD40, will also help to keep all internal parts working well. After long periods where the fire has been out of use, the chimney and appliance flueways should be cleaned before lighting.

Door Seals

For the fire to operate correctly it is important that the door seals are in good condition. Check that they do not become worn or frayed and replace them when necessary.

Servicing

It is recommended that the fire is serviced once a year to keep it in first class working order. After cleaning out the firebox thoroughly, check that all internal parts are in good working order, replacing any parts that are beginning to show signs of wear. Check that the door seals are in good condition and that the door seals correctly.

Repairs or modifications may only be carried out by the Manufacturer or their approved agents. Use only genuine Charnwood replacement parts.

THROAT PLATE AND FLUEWAY CLEANING

It is important that the throat plate and all the stove flueways are kept clean in order to prevent potentially dangerous fume emission. Check by looking up into the firebox for signs of soot or fly-ash on the throat plate and sides of the firebox. If there are signs of a build up of soot or fly-ash then cleaning is necessary. Cleaning should occur at least once a month and more frequently if required. Let the fire out and ensure it is cold before carrying out these operations. If necessary, wear your Charnwood gloves to prevent irritation from soot deposits.

The throat plate consists of two firebrick panels which rest on the central bracket and the two side bricks. To lower, push the brick up towards the topmost corner of the stove, and lower down diagonally (see Fig. 8). Any sooty deposits should then be swept from the plate and into the fire.

Return the throat plates to their correct position by reversing the above method, ensuring they slot onto the bracket and rest securely on the side panels.

CHIMNEY SWEEPING

The chimney should be swept at least twice a year. It will generally be possible to sweep the chimney through the appliance. If the stove is fitted in place of an open fire, the chimney should be swept one month after installation to clear any soot falls which may have occurred due to the difference in combustion between the stove and the open fire.

First remove the fuel retainer and the throat plate. Then sweep the chimney ensuring that soot is removed from all horizontal surfaces after sweeping.

In situations where it is not possible to sweep through the appliance the installer will have provided alternative means, such as a soot door. After sweeping the chimney the appliance flue outlet and the flue pipe connecting the stove to the chimney must be cleaned with a flue brush.

After clearing any soot from within the stove, replace the throat plate (see Fig. 8) and the fuel retainer.

Different types of sweep's brushes are available to suit different flueways. For standard brick chimneys, a wire centre sweep's brush fitted with a guide wheel is recommended. For prefabricated insulated chimneys the manufacturers instructions with regard to sweeping should be consulted.

CO ALARM

Your installer should have fitted a CO alarm in the same room as the appliance. If the alarm sounds unexpectedly, follow the instructions given under "Fume Emission" overleaf.

Fig. 8 Throat plate position and lowering

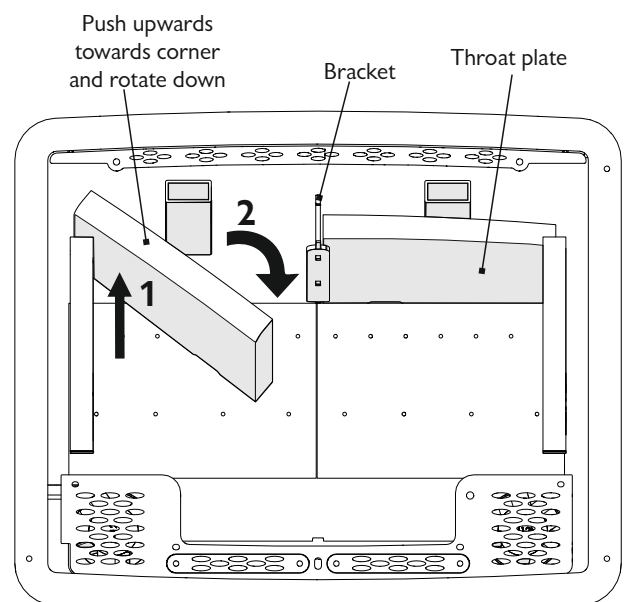

Lowering the throat plate

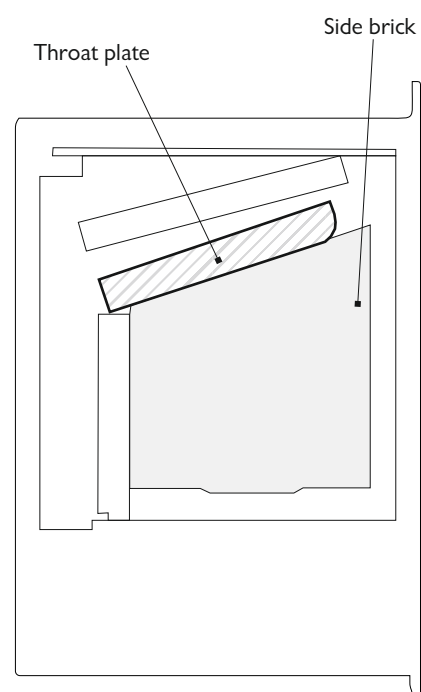

Side View

FIRE WILL NOT BURN

Check that:

- a) the air inlet is not obstructed in any way,
- b) chimneys and flueways are clear,
- c) a suitable fuel is being used,
- d) there is an adequate air supply into the room,
- e) an extractor fan is not fitted in the same room as the stove.
- f) there is sufficient draw in the chimney. Once the chimney is warm a draught reading of at least 1.3 mm (0.05 inches) water gauge (12.5Pa) should be obtained.

BLACKENING OF DOOR GLASS

Differences in chimney draughts mean that the best settings of the air controls will vary for different installations. A certain amount of experimentation may be required, however the following points should be noted and with a little care should enable the glass to be kept clean in most situations:

- a) Wet or unseasoned wood, or logs overhanging the front fence will cause the glass to blacken.
- b) The airwash relies on a supply of heated air to keep the glass clean. Therefore, when lighting the stove, allow the firebed to become well established before closing the air control. This may also be necessary when re-fuelling the stove.
- c) When re-fuelling keep the fuel as far back from the front fence as possible. Do not try to fit too much fuel into the firebox.
- d) Do not completely close the air control.

It is always more difficult to keep the glass clean when running the stove very slowly for long periods.

If blackening of the glass still occurs check that all flue connections and the blanking plate are well sealed. It is also important that the chimney draw is sufficient and that it is not affected by down-draught. When the chimney is warm a draught reading of at least 1.3 mm (0.05 inches) water gauge (12.5Pa) should be obtained. Some blackening of the glass may occur below the level of the fuel retainer. This will not obscure the view of the fire or affect its performance.

FIRE BLAZING OUT OF CONTROL

Check that:

- a) The door is tightly closed.
- b) The air control is fully closed.
- c) A suitable fuel is being used.
- d) Door seals and air slide are intact.

FUME EMISSION

Warning Note:

Properly installed and operated this appliance will not emit fumes.

Occasional fumes from de-ashing and re-fuelling may occur.

Persistent fume emission is potentially dangerous and must not be tolerated. If fume emission does persist, then the following immediate actions should be taken:

- a) Open doors and windows to ventilate the room.**
- b) Let the fire out and safely dispose of the fuel from the appliance.**
- c) Check for flue or chimney blockage, and clean if required.**
- d) Do not attempt to re-light the fire until cause of fume has been identified. If necessary, seek professional advice.**

The most common cause of fume emission is flueway or chimney blockage. For your own safety these must be kept clean.

CHIMNEY FIRES

If the chimney is thoroughly and regularly swept, chimney fires should not occur. However, if a chimney fire does occur close the air control, and tightly close the door of the appliance. This should cause the chimney fire to go out in which case the controls should be kept closed until the stove has gone out. The chimney and flueways should then be cleaned. If the chimney fire does not go out when the above action is taken then the fire brigade should be called immediately. After a chimney fire the chimney should be carefully examined for any damage. Expert advice should be sought if necessary.

IF YOU NEED FURTHER HELP

If you need further help with your Charnwood then your Installer will be able to provide the answers to most questions. Your Local Charnwood Premier Dealer has a great deal of experience and will also be able to provide helpful advice. Further help is available from the Charnwood Customer Services department who will be pleased to give advice, if necessary.

UNPACKING THE STOVE

The stove arrives bolted and strapped to its pallet. There must be adequate facilities for unloading and manoeuvring into position. The convection casing is first removed from the top of the stove. The stove is released from the pallet by removing the pallet bolts using a 10mm Spanner. The pallet brackets can now be removed from the pallet and the stove can now be moved to its final position. The pallet is intended to be cut up and used for kindling fuel.

HEALTH AND SAFETY PRECAUTIONS

Please take care when installing the stove that the requirements of the Health and Safety at Work Act 1974 are met. Adequate facilities must be available for loading, unloading and site handling.

Some types of fire cement are caustic and should not be allowed to come into contact with the skin. In case of contact, wash with plenty of water.

If there is a possibility of disturbing any asbestos in the course of installation then please use appropriate protective equipment.

There must not be an extractor fan fitted in the same room as the stove as this can cause the appliance to emit fumes into the room.

The combustion air supply ducting must be connected to a suitable, permanently open air inlet. See 'Air supply' section for details. This stove is capable of intermittent operation. This stove is not suitable for use in a shared flue system.

In addition to these instructions the requirements of BS 8303 and BSEN 15287-1:2007 must be fulfilled. Local Authority Bylaws and Building Regulations given in approved document J, including those referring to national and European Standards, regarding the installation of Solid Fuel burning appliances, flues and chimneys must also be observed.

The installation of any electrical services must be carried out by a registered competent electrician and in accordance with the requirements of the latest issue of BS 7671

CO ALARMS

Building regulations require that whenever a new or replacement fixed solid fuel or wood/biomass appliance is installed in a dwelling a carbon monoxide alarm must be fitted in the same room as the appliance. Further guidance on the installation of the carbon monoxide alarm is available in BS EN 50292:2002 and from the alarm manufacturer's instructions. Provision of an alarm must not be considered a substitute for either installing the appliance correctly or ensuring regular servicing and maintenance of the appliance and chimney system.

SPECIFICATION

	Bay 5	Bay 5 GT	Bay 5 VL
Output	5kW (17,061BTU/h)	5.8kW (19,790 BTU/h)	5kW (17,061BTU/h)
Mass	94.3kg	105kg	94.3kg
Flue Gas Temperature	279°C	286°C	279°C
Flue Gas Mass Flow	4.1g/s	4.8g/s	4.1g/s
Average Refuelling Cycle	0.75hrs	0.75hrs	0.75hrs
Maximum Log Size	Length 480mm Diameter 75mm	Length 480mm Diameter 75mm	Length 480mm Diameter 75mm

Outputs were achieved burning seasoned hardwood logs over a 45 minute refuelling period.

CHIMNEY

In order for the appliance to perform satisfactorily the chimney height must not be less than 4 metres measured vertically from the outlet of the stove to the top of the chimney. The internal dimensions of the chimney MUST NOT BE LESS THAN 150 mm (6 inches).

If an existing chimney is to be used it must be swept and checked, it must be in good condition, free from cracks and blockages, and should not have an excessive cross sectional area. If you find that the chimney is in poor condition then expert advice should be sought regarding the necessity of having the chimney lined. If it is found necessary to line the chimney then a lining suitable for Solid Fuel must be used.

If the stove has been fitted in the place of an open fire, it is recommended that the chimney is swept one month after installation to clear any soot falls which may have occurred due to the difference in combustion between the stove and the open fire.

If there is no existing chimney then a prefabricated block chimney or a twin walled insulated stainless steel flue to BSEN 15287-1:2007 can be used either internally or externally. These chimneys must be fitted in accordance with the manufacturers instructions and Building Regulations.

Single wall flue pipe is suitable for connecting the stove to the chimney but is not suitable for using for the complete chimney.

It is important that there is sufficient draw in the chimney and that the chimney does not suffer from down-draught. When the chimney is warm the draw should be not less than 1.3mm (0.05 inches) water gauge (12.5 Pa). If it is found that there is excessive draw in the

chimney then a draught stabiliser should be fitted. If in doubt about the chimney seek expert advice.

HEARTH AND FIRE SURROUND

The stove must be installed above a fireproof hearth of minimum 250mm depth in accordance with local building regulations, but ideally 580mm deep to match the projection of the open door. The positioning of the stove and the size of the hearth are governed by building regulations for solid fuel appliances. If in doubt as to the positioning of the stove expert advice should be sought either from the supplier or the local building inspector.

If a wooden mantelpiece or beam is used in the fireplace it should be a minimum of dimension 'D' from the appliance. In some situations it may be necessary to shield the beam or mantelpiece to protect it.

In order for the appliance to fit into the fire surround there must be a flat area around the opening. Details are shown in Fig. 10 & 12.

PREPARATION OF FIREPLACE

If the fireplace contains combustible materials, two air vents of 80mm

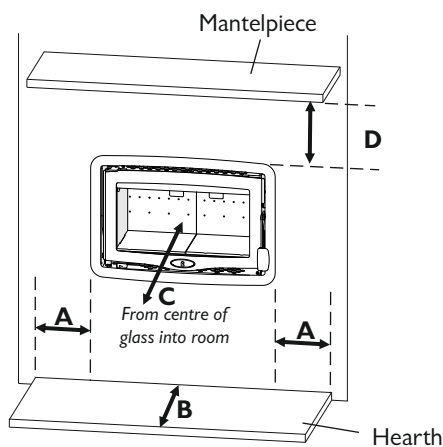

	Bay 5 & VL	Bay 5GT
Dimension A:	190mm	150mm
Dimension B:	250mm	250mm
Dimension C:	900mm	1000mm
Dimension D:	350mm	460mm

(Bay 5 & VL) or 100mm (Bay 5GT) diameter must be fitted through the insulation and the wall of the fireplace to provide a continual air flow around the stove. Similar vents must be placed between the closure plate and the top of the stove to ventilate the cavity. It is recommended that Calcium Silicate board is used (80mm board for Bay 5 & VL, 100mm board for Bay 5GT), with a 100mm air gap between the stove and the insulation (see Fig. 11).

If the fireplace does not contain combustible materials, it is still recommended to have a layer of insulation or ventilate the space between the casing and the outer wall. The insulation may consist of a layer of mineral fibre or a vermiculite concrete mix (see Step 4). If rockwool is being used, insert this into the opening before sliding in the convection casing.

Before fitting the appliance into an existing fireplace remove the fireback and any loose in-fill material.

The surround and opening for the appliance must conform with Fig.12. The flat area around the opening should be a minimum of 700mm wide and 600mm high. Ensure that the hearth and the base in the opening are flat, level, and at right angles to the surround.

For the Bay 5GT, consider where the low voltage power supply for the fans is to be situated, and install electrical conduit from that point to back left of the convection casing.

Fig. 11 Air vents and insulation in a fireplace containing combustible materials

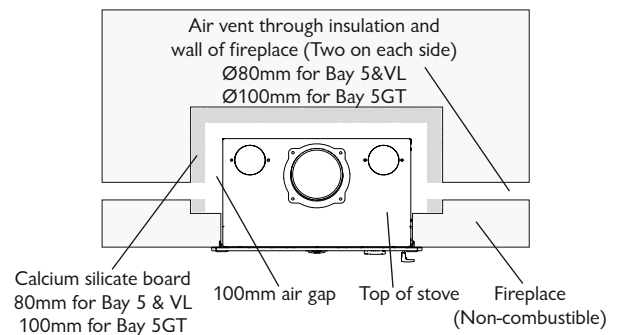
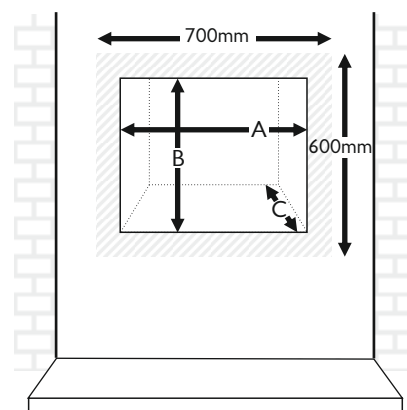

Fig. 12 Limiting Dimensions of Surround and Opening



The shaded grey area on the face of the surround is the minimum flat area required for inset installation.

	Dimension A:	Dimension B:	Dimension C:
Bay 5 & VL	Min. 615mm	Min. 410mm	Min. 380mm
	Max. 650mm	Max. 440mm	
Bay 5GT	Min. 620mm	Min. 510mm	Min. 400mm
	Max. 650mm	Max. 540mm	

Fig. 13 Installation in a standard chimney

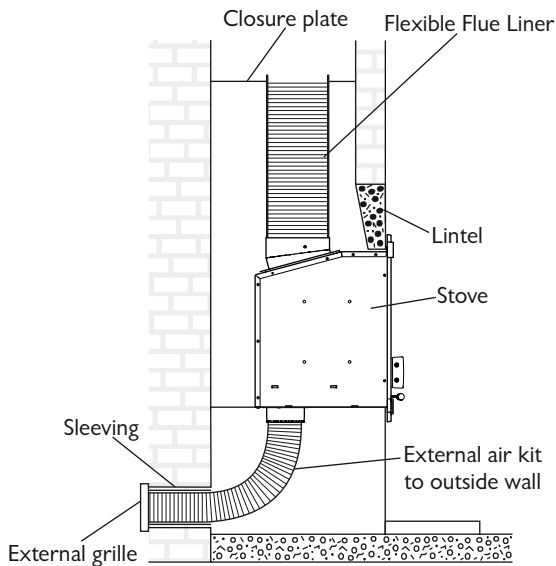

CONNECTING THE FANS (BAY 5GT ONLY)

The adaptor provided must be connected to a suitable mains socket. For the UK adaptor this is a 240 volt 50 Hz. a.c. supply. For the European adaptor this is a 220 volt 50 Hz. a.c. supply. **THE MAINS ADAPTOR MUST BE USED. DO NOT CONNECT A MAINS SUPPLY DIRECTLY TO THE STOVE.**

Plug the connector from the adaptor into the socket on the wire from the stove. Cable clips or conduit should be used to retain the wire where necessary. If it is necessary to extend the wire then ensure that the correct polarity is maintained. The centre pin on the plug must be positive. There is a thermal cut out linked into the fan control. This means that the fans will not operate until the stove warms up.

AIR SUPPLY

The fire needs air for combustion, there are various ways of supplying this, and they must meet the requirements of the building regulations.

One way of meeting this requirement as outlined in Approved Document J is to have a permanently open air vent into the room that the stove is fitted to as per the table below:

If using this method then the air supply ducting may be terminated in

Air permeability $m^3/(h.m^2)$	Minimum vent area $cm^2(in^2)$		
	Bay 5GT	Bay 5	Bay VL
>5.0	5.5 (0.9)	not required	not required
<5.0	33 (5.1)	27.5 (4.3)	27.5 (4.3)

the room, or the ducting connections on the stove can be removed, as detailed in figure 14 so that air is taken from between the fire box and the convection casing.

Alternatively a fixed ducted air supply method can be used as shown in fig. 13. One end of the air supply ducting is connected to the stove and the other is terminated outside. The ducting must be 100mm dia, non-combustible, less than 5.5m long and must not have more than five 90° bends and two 45° elbows. It must be sleeved where it passes through the external wall. The inlet must be permanently open and the duct free of any constrictions. The inlet must have a suitable grill to prevent entry by vermin, and should be positioned so that blockage by leaves or other debris will be avoided. Ensure that rain or flood water will not enter the duct. A spillage test must be carried out during commissioning to verify adequate air supply for combustion - see the section on Commissioning.

External air kits are available, please contact Charnwood for more information (Ref TIS 120)

HETAS product approval covers this appliance when installed in accordance with the manufacturer's instructions and relevant standards. As there is currently no standard for Ducted Combustion Air Supply this does not fall within the remit for HETAS product approval. Responsibility for the specification of this and for appropriate manufacturers' instructions is carried by the appliance manufacturer, as allowed for under the Building Regulations.

Fig 14 Fitting the duct covers

Bay 5 & VL

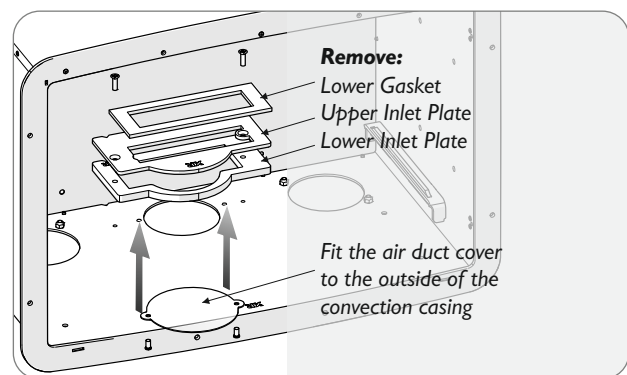

Bay 5GT

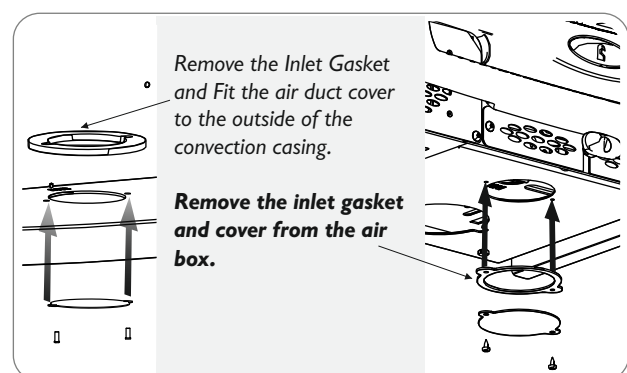

1. Attach flue collar to length of rigid flue pipe

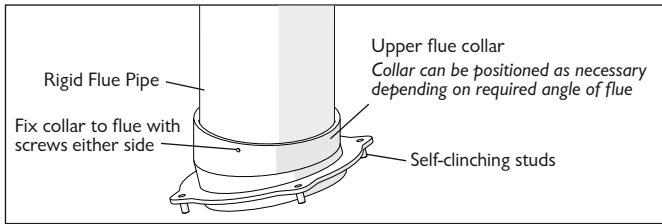

2. Insert convection casing into opening

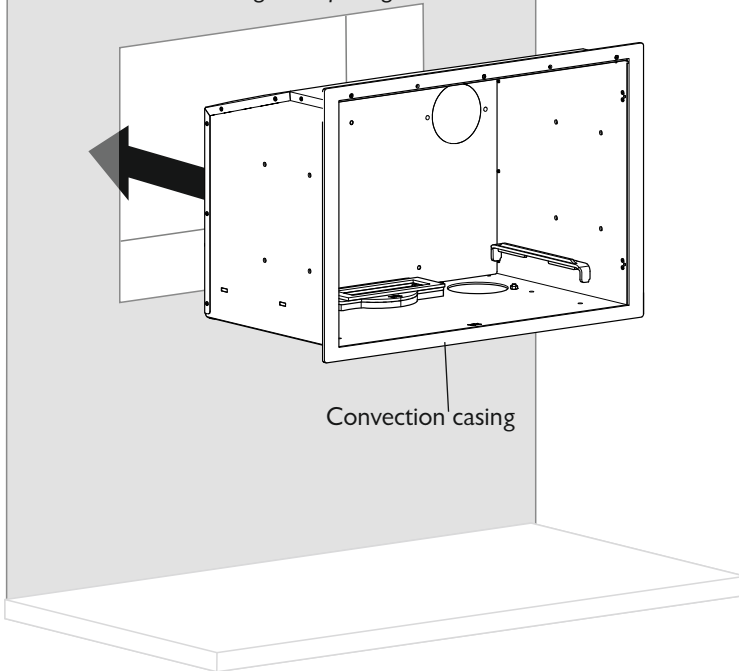

1. ATTACH FLUE COLLAR TO THE FLUE PIPE

It is recommended to use a flexible flue liner with a length of rigid flue pipe. Fix the upper flue collar to the flue pipe through the screw holes in the side of the ring. The flue collar can be attached at any angle depending on the required angle of the flue.

It is vital that the connections at both ends of the flue pipe are well sealed. The flue pipe and collar can be sealed with fire cement and/or a gasket. A closure plate should be used at the top end of the flue pipe.

Once the collar is attached, push the flue pipe and flue collar up out of the way for the casing to be inserted.

2. INSERT THE CONVECTION CASING INTO THE OPENING

Make sure the four self-clinching studs are in the holes in the flue collar, pointing downwards. Slide the convection casing into position in the opening until the flue outlet lines up with the flue pipe.

For the Bay 5GT, thread the free socket and wire for the fans on the outside of the convection casing through the conduit and insert convection casing into the opening. If it is necessary to extend the wire, it must be done at this stage, ensuring correct polarity is maintained.

3. MAKE FLUE CONNECTION

Reaching through the flue outlet, pull the flue collar down through the outlet until the studs line up with the four holes in the convection casing. Use nuts to secure the studs into place.

4. ATTACH AIR SUPPLY SPIGOT TO CONVECTION CASING

Reaching through the air inlet, pull the air supply spigot up so that its studs protrude through the convection casing and use nuts to secure the studs into place. Ensure that the air supply duct is not kinked during the fitting process

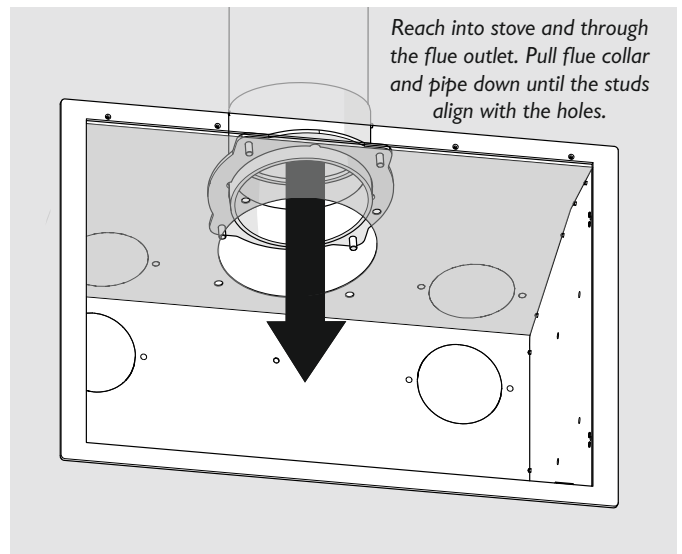
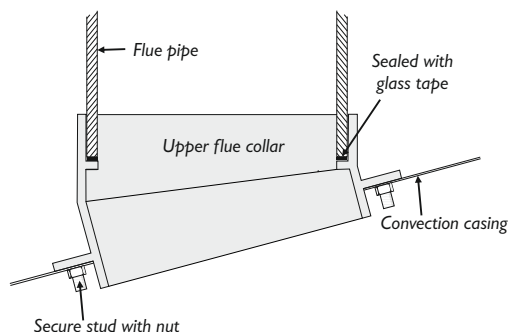

5. SECURE THE CASING TO THE WALL

Secure the casing in the opening by inserting screws, as shown on the diagram. The stove can be screwed down through the base or through the sides as required.

6. FILL WITH INSULATION AND MAKE GOOD THE OPENINGS

If you are using the vermiculite method of insulating the convection casing, pour down from the top of the chimney. Fill in the space between the casing and the brickwork and around the flue pipe with a vermiculite or perlite concrete mix (see fig. 12). The recommended mixture is 6 parts of vermiculite or perlite to 1 part cement. Add only enough water so that a few drops are released when a handful of the mixture is squeezed.

Make good the opening at the top and sides of the convection casing ensuring that a good seal is made with the side flanges. It is recommended to use heat resistant plaster on the wall surrounding the stove.

If for any reason it is not going to be possible to sweep the chimney through the appliance, a soot door must be fitted.

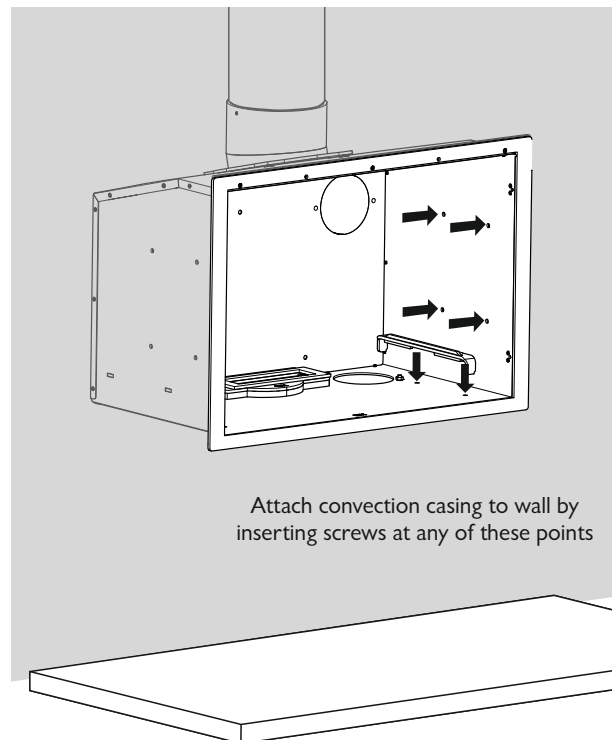

7. SLIDE IN THE STOVE

For the Bay 5GT, remove the RH fan by undoing the two retaining screws. Move the stove into the position shown and attach the free wire on the inside of the convection casing to the pins marked "pwr" +12V on the circuit board located below the LH fan. Attach the LH fan wire to the PCB.

Carefully slide the stove into the convection casing until the flue outlet lines up with the upper flue collar and the air inlet engages at the base of the stove.

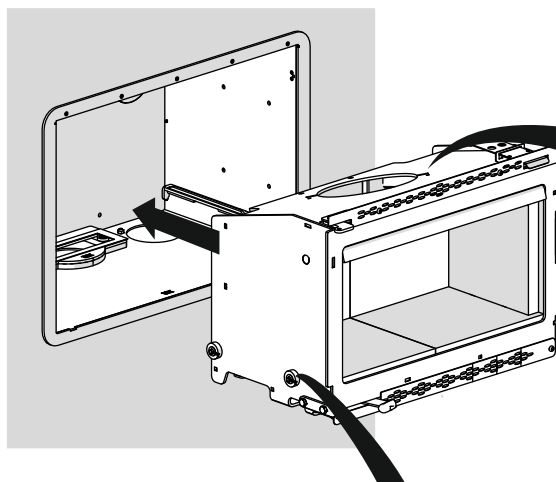

8. INSERT COACH BOLTS

From the inside of the stove, insert coach bolts in to slots A and B so that they hang down into the stove. These are held in place by the clips and will secure the flue collar.

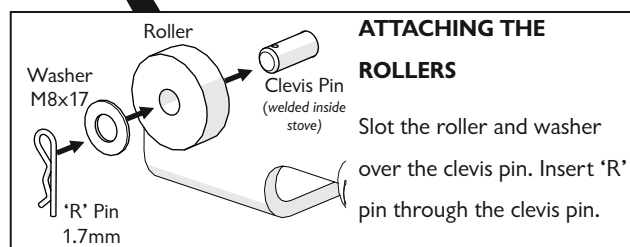
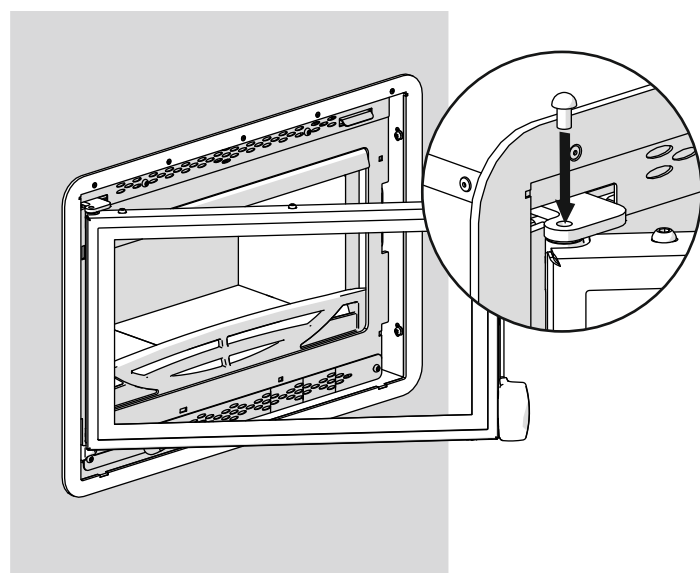
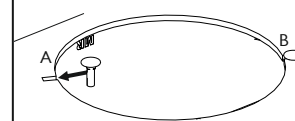

9. FIT THE DOOR

Carefully lift the door onto the lower hinge pin and insert the upper hinge pin through the hinge post and the door

9. SECURE THE FLUE ADAPTORS

Working through the stove, line up the inner flue collar to meet the upper flue collar, carefully easing the ends of the coach bolts through the holes. Fit the nuts onto the ends of the coach bolts and tighten.

Check that the flue pipe is not obstructed or restricted in any way and that all joints are well sealed.

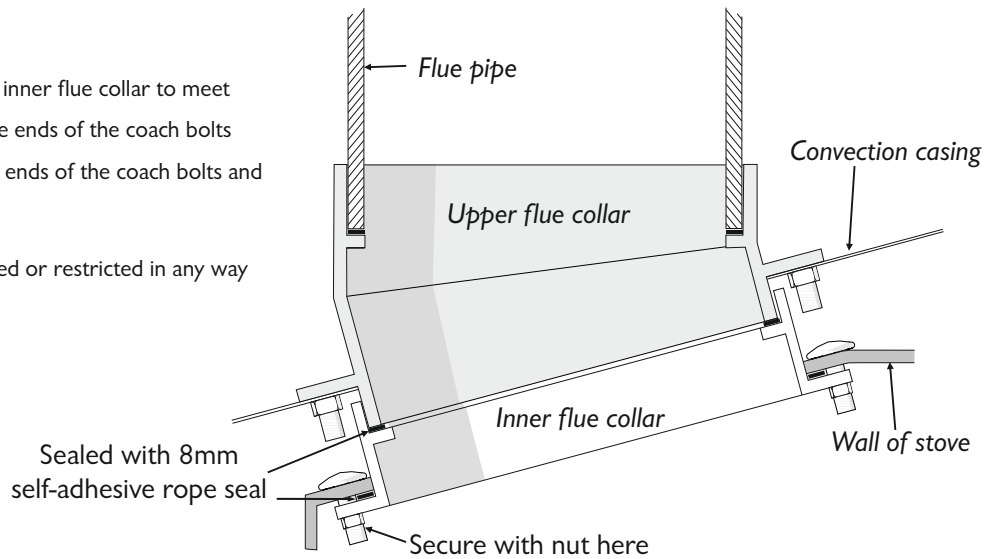

Bay & Bay 5GT

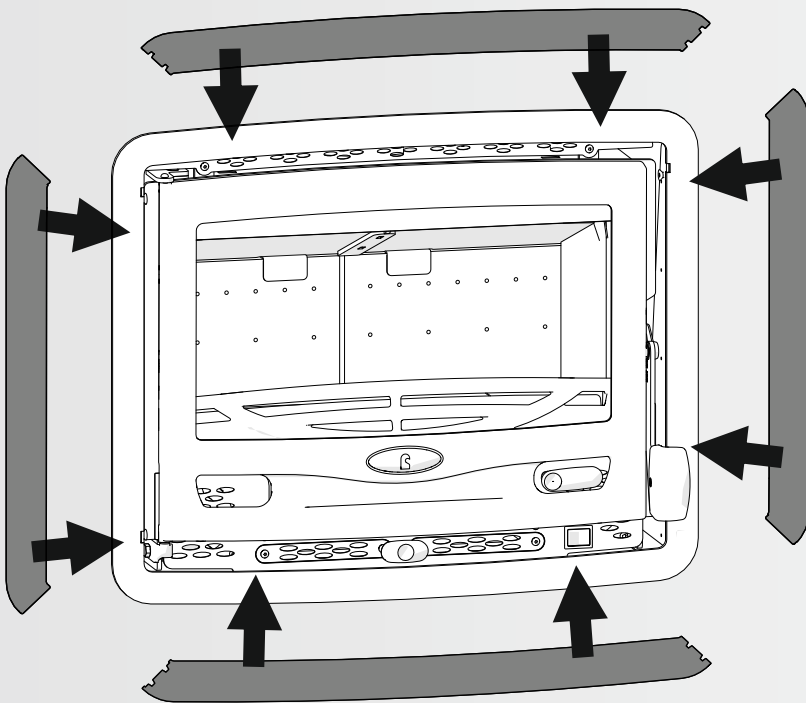

10. ATTACHING THE BAY 5- 5GT FRAME

Finally, fit the frame to the front of the stove. First, hold the top and bottom pieces in place. The two side panels fit onto the top and bottom pieces and hold the frame together. Slot into position and screw into place with a countersunk screw.

Ensure the firebox is central in the casing and that the door handle operates correctly. If necessary, adjust the firebox position in the casing.

ATTACHING THE BAY VL FRAME

The enamel frame is one piece and is fitted to the front of the stove. Slot the frame into position and screw into place using a button head allen screw, as shown in the diagram below. Take care not to over tighten the allen screw as it can damage the enamel finish.

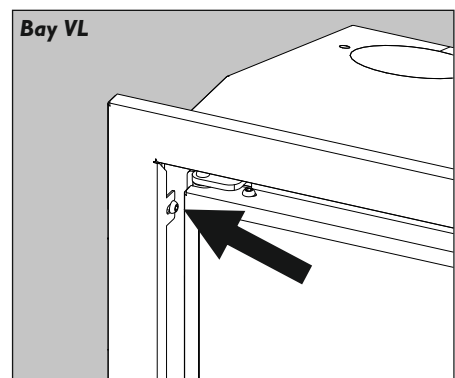
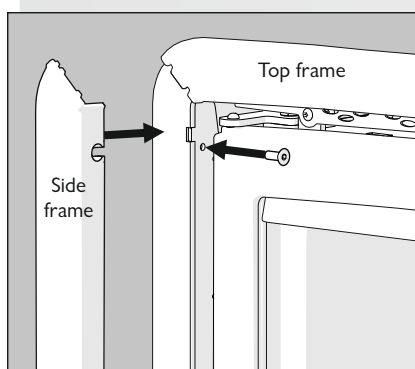

FITTING THE OPTIONAL BASE ASSEMBLY BAY 5 & 5GT

1. With the firebox removed, roll the outer convection casing onto its back and fasten the assembly into position using four M6x20 screws and nuts. Insert the screws through the holes in the underside of the casing from the inside and fit the nuts onto the outside of the base. Do not fully tighten the screws at this stage.

2. Attach the lower fireplace trim into position onto the base frame. This part replaces the lower trim piece (002/MR113). Use two M8x10 screws and finger tighten them to allow adjustment.

3. Undo the foot adjustment screws on the base assembly so that they are just below the lower level of the base frame. Stand the whole assembly up onto the base and trial fit into the fireplace opening. Adjust the feet to overcome any rocking, should the fireplace floor be uneven.

4. Trial fit the side trim pieces (002/XR112 or 002/MR112) and adjust the lower fireplace trim position to obtain a good fit. Once everything is aligned, tighten all fasteners.

Fig. 13 Fitting the optional base assembly

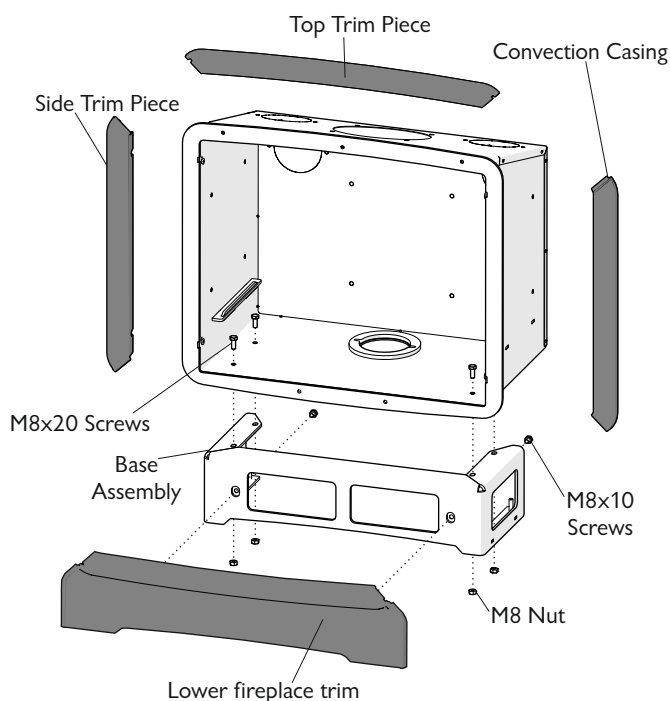

PRE LIGHTING CHECK

Before initial lighting check the following points:

1. The bottom grate bars must all be fitted and should move freely and easily when the riddling mechanism is operated.

2. The plates round the sides and back of the grate must be in position and sitting correctly.

3. The throat plate must be fitted in the roof of the appliance (as shown in Fig. 8).

4. Check that the front fence is fitted correctly and that the door closes properly.

COMMISSIONING

On completion of the installation allow a suitable period of time for the fire cement and mortar to dry out before commissioning the fire. Before lighting, first check that there is an updraft in the chimney - open the door of the stove and hold a lit match at the top of the door opening. If the flame is pulled into the stove this indicates that there is an updraft and the fire may be lit. If the flame is pushed out from the stove then this indicates that a downdraft is present, the flue will need to be warmed to produce an updraft and then checked using the same procedure with the lit match. The flue may be warmed by lighting a single sheet of newspaper, or a firelighter, within the stove before attempting to light a proper fire. Sometimes it may be necessary to open a window to give an initial draw.

A spillage test must be carried out to confirm safe operation with doors and windows closed and any extract fans in operation (i.e. worst conditions) Warm the appliance and flue before carrying out the spillage test. Light a smoke match from the middle of a bed of embers, hold the match approximately 20mm above the ember bed and ensure that the smoke is carried up the flue and emitted safely. Also check all joints and seals. On successful completion of the spillage test please leave the operating instructions and tools with the customer and advise them on the use of the appliance. If the spillage test fails the cause must be found and rectified, or the appliance decommissioned and the customer instructed not to use the appliance until it can be shown to operate safely.

CAA AND SMOKE CONTROL

The Clean Air Act 1993 and Smoke Control Areas

Under the Clean Air Act local authorities may declare the whole or part of the district of the authority to be a smoke control area. It is an offence to emit smoke from a chimney of a building, from a furnace or from any fixed boiler if located in a designated smoke control area. It is also an offence to acquire an "unauthorised fuel" for use within a smoke control area unless it is used in an "exempt" appliance ("exempted" from the controls which generally apply in the smoke control area).

In England appliances are exempted by publication on a list by the

Secretary of State in accordance with changes made to sections 20 and 21 of the Clean Air Act 1993 by section 15 of the Deregulation Act 2015. Similarly in Scotland appliances are exempted by publication on a list by Scottish Ministers under section 50 of the Regulatory Reform (Scotland) Act 2014.

In Northern Ireland appliances are exempted by publication on a list by the Department of Agriculture, Environment and Rural Affairs under Section 16 of the Environmental Better regulation Act (Northern Ireland) 2016.

In Wales appliances are exempted by regulations made by Welsh Ministers.

Further information on the requirements of the Clean Air Act can be found here: <https://www.gov.uk/smoke-control-area-rules>

Your local authority is responsible for implementing the Clean Air Act 1993 including designation and supervision of smoke control areas and you can contact them for details of Clean Air Act requirements.

The Bay 5, Bay 5 VL and the Bay 5GT have been recommended as suitable for use in smoke control areas when burning wood logs.

Bay 5 DIMENSIONS (mm)

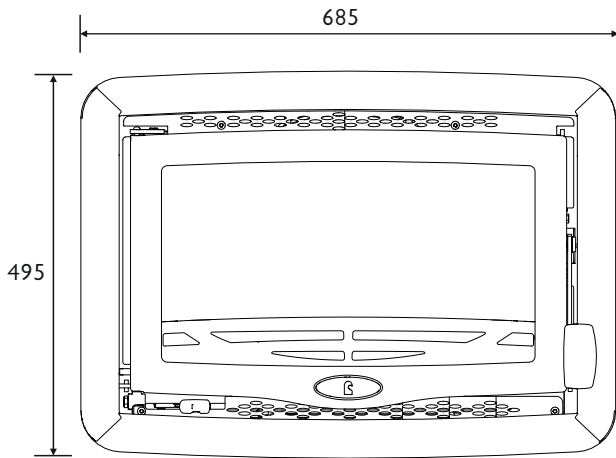

FRONT VIEW

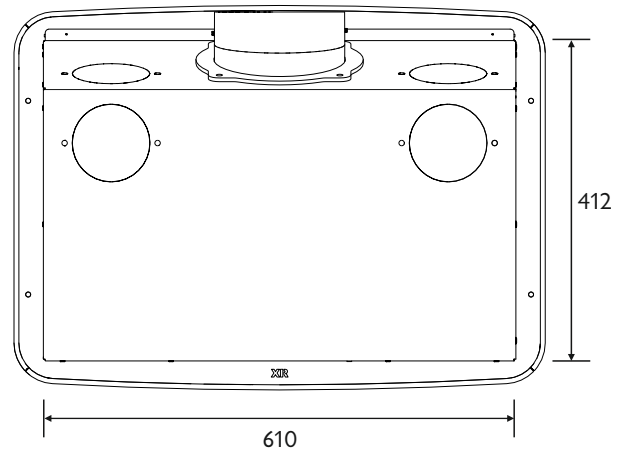

BACK VIEW

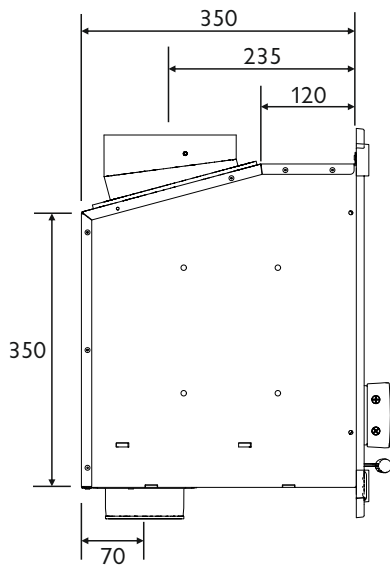

SIDE VIEW

Note: Door extends a maximum of 573mm from front of stove when open.

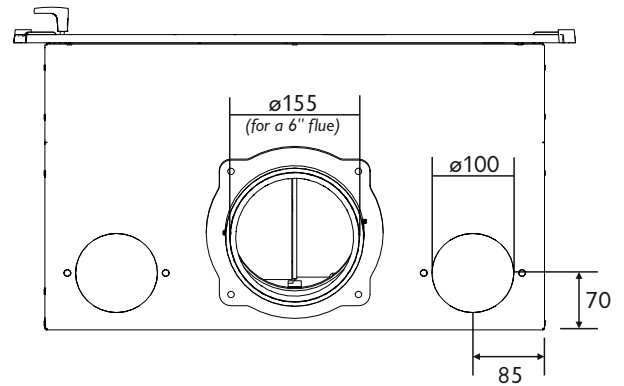

PLAN VIEW

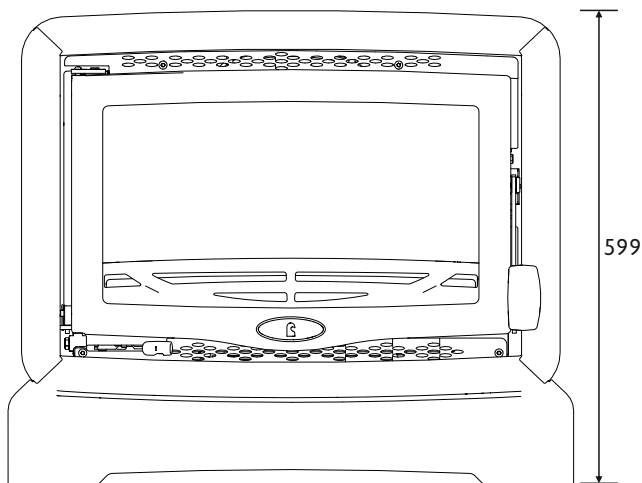

FRONT VIEW WITH FIREPLACE TRIM

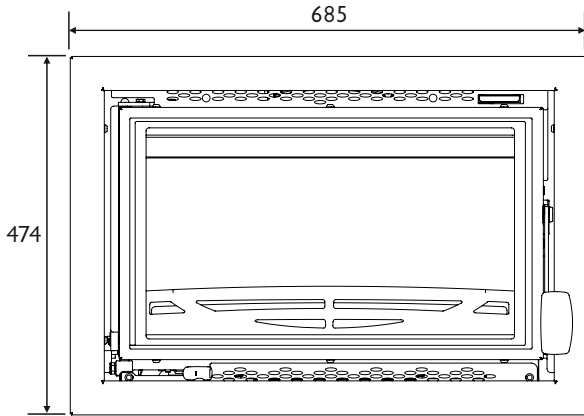

FRONT VIEW

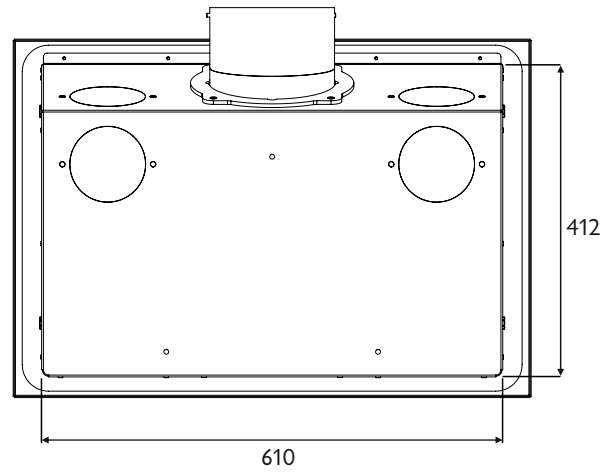

BACK VIEW

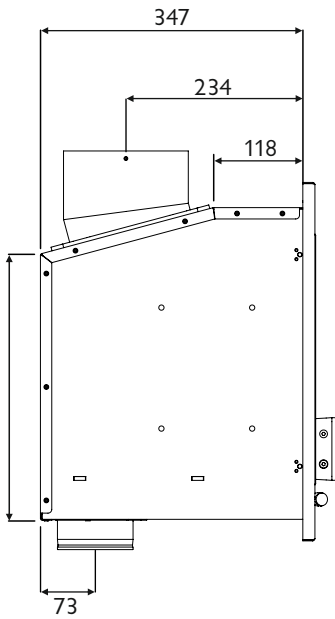

SIDE VIEW

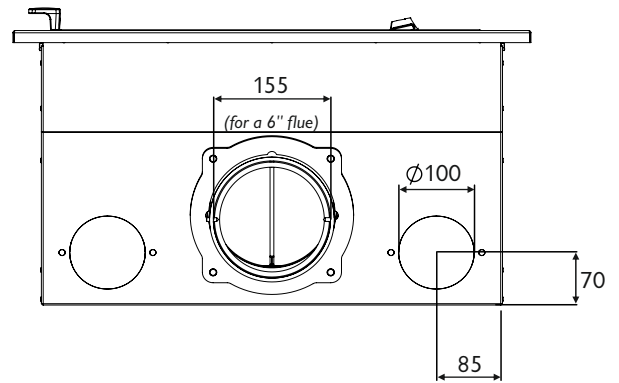

PLAN VIEW

Note: Door extends a maximum of 573mm from front of stove when open.

Bay 5GT DIMENSIONS (mm)

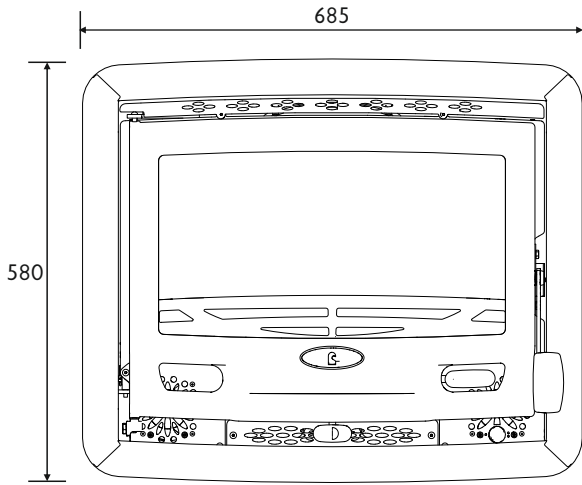

FRONT VIEW

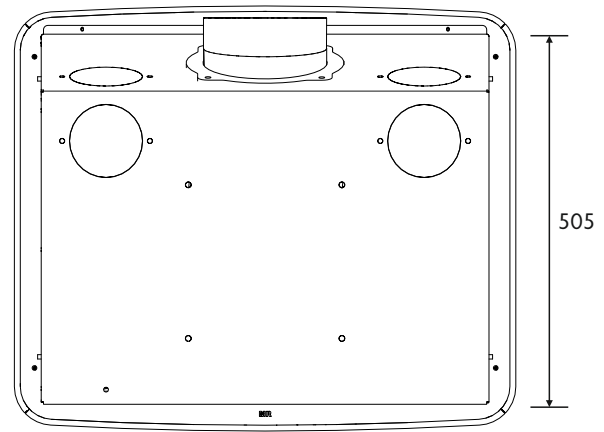

BACK VIEW

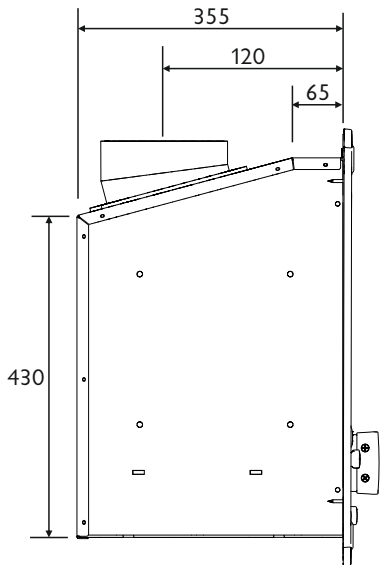

SIDE VIEW

Note: Door extends a maximum of 573mm from front of stove when open.

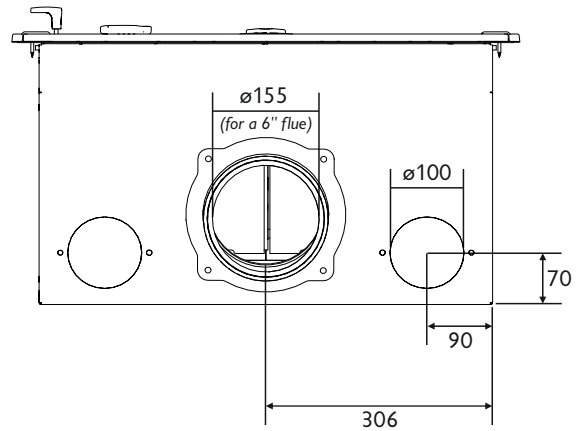

PLAN VIEW

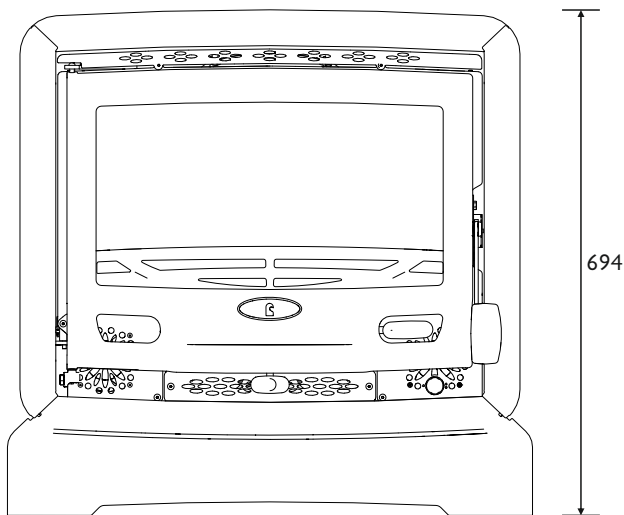

FRONT VIEW WITH FIREPLACE TRIM

Bay 5 Parts List

Issue D

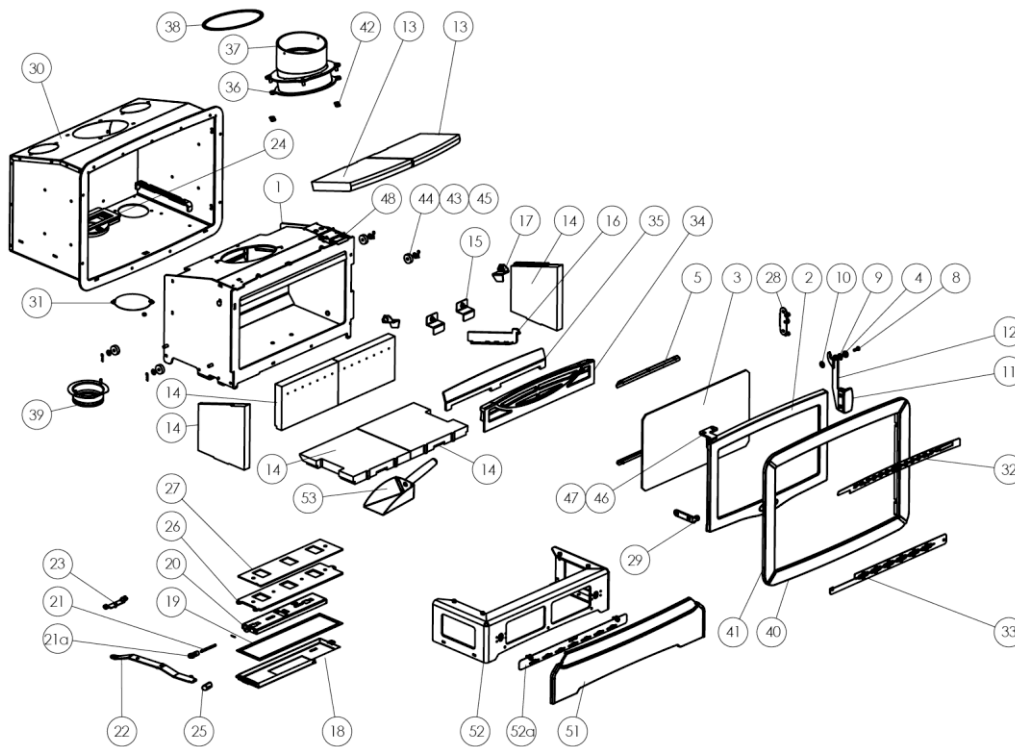

Item	Part No.	Description	Item	Part No.	Description
1	001/XR010	Firebox	28	004/MR044	Latch Plate
2#	002/XR001/A	Door Assembly	29	002/XR020	Lower Hinge Bracket
3	006/MR019	Glass	30	010/XR011	Convection Casing
4	008/MR047	Handle Pivot Boss	31	004/MR060	Air Duct Cover
5	004/XR074	Glass Retainer	32	004/XR027	Screen Top
6*	008/MR085	Glass Seal	33	004/XR026	Screen Lower
7*	008/XR076	Door Seal	34	002/MR017	Fence
8	008/FFS046	M6x20 CSK Allen Screw	35	010/MR078	Ash Barrier
9	008/FFW027	M10 Wavy Washer	36	010/XR098	6" Lower Flue Adaptor
10	008/FFW007	M10x19 Washer	37	010/XR096	6" Upper Flue Adaptor
11	010/MR038	Handle Assembly	38	008/XR044	Inner Flue Gasket
12	011/MR031S	Set of Baffle Firebricks	39	010/MR126	100mm Spigot Assy
13	011/XR030S	Set Base, Back & Side Bricks	40#	002/MR113	Top/Bottom Trim
14	004/XR008	Back Brick Bracket	41#	002/XR112	Side Trim
15	010/XR087	Throat Plate Support Bracket	42	004/GR090	Fastener Retainer
16	004/XR025	Side Brick Bracket	43	008/FFW007	M8 Washer
17	004/XR055	Air Slide Cover	44	010/XR085	Roller
18	008/XR063	Air Box Upper Gasket	45	008/FFP006	R-Pin
19	004/XR007	Air Control Slider	46	010/XR041	Upper Hinge Bracket
20	004/XR064	Control Rod	47	010/XR042	Hinge Spacer
21	008/FFM056	Rod End	48	012/XR014	Serial No Label
22	010/XR022	Air Slide Control Handle	49	004/MR116	Serial Plate Carrier
23	004/XR058	Clicker Assembly	50	004/MR115	Serial No bracket
24	008/XR062	Airbox Lower Gasket	51#	002/MR114	Fireplace Trim (Optional Extra)
25	008/XR012	Control Knob	52	010/XR093	Fireplace Stand (Optional Extra)
26	004/XR072	Air Control Plate	53	004/MR118	Fireplace Trim Infill
27	008/XR073	Air Control Gasket	54	010/XR088	Ash Scoop

* These items are not shown on the drawing.
Please specify colour when ordering.
This drawing is for identification purposes only.

To obtain spare parts please contact your local stockist giving Model, Part No. and Description. In case of difficulty contact the manufacturer at the address shown.

Bay 5VL Parts List

Issue C

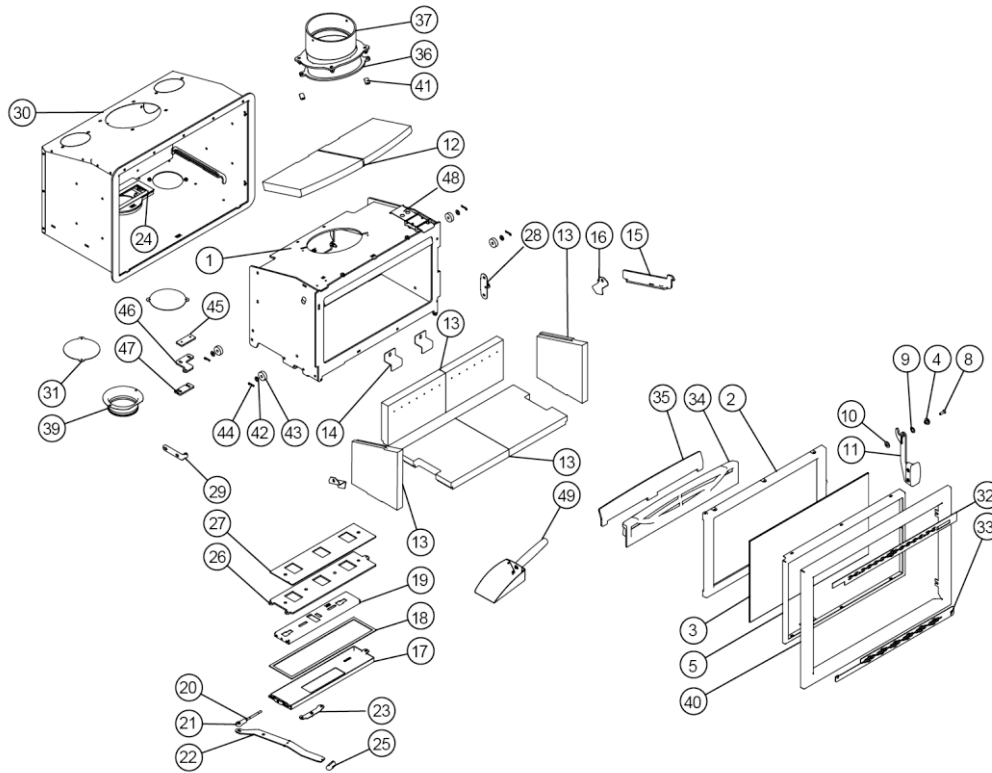

ItemPart No.	Description
1	001/XR010 Firebox
2	002/BT001 Door Casting
3	006/BT018 Glass
4	008/MR047 Handle Pivot Boss
5#	004/BT023 Glass Trim
7*	008/XR076 Door Seal
8	008/FFS046 M6x20 CSK Allen Screw
9	008/FFW027 M10 Wavy Washer
10	008/FFW007 M10x19 Washer
11	010/MR038 Handle Assembly
12	011/MR0315 Set of Baffle Firebricks
13	011/XR0305 Set Base, Back & Side Bricks
14	004/XR008 Back Brick Bracket
15	010/XR087 Throat Plate Support Bracket
16	004/XR025 Side Brick Bracket
17	004/XR055 Air Slide Cover
18	008/XR063 Air Box Upper Gasket
19	004/XR007 Air Control Slider
20	004/XR064 Control Rod
21	008/FFM056 Rod End
22	010/XR022 Air Slide Control Handle
23	004/XR058 Clicker Assembly
24	008/XR062 Airbox Lower Gasket
25	008/XR012 Control Knob

ItemPart No.	Description
26	004/XR072 Air Control Plate
27	008/XR073 Air Control Gasket
28	004/MR044 Latch Plate
29	002/XR020 Lower Hinge Bracket
30	010/XR011 Convection Casing
31	004/MR060 Air Duct Cover
32	004/BT025 Screen Top
33	004/BT029 Screen Lower
34	002/MR017 Fence
35	010/MR078 Ash Barrier
36	010/XR098 6" Lower Flue Adaptor
37	010/XR096 6" Upper Flue Adaptor
38#	008/XR044 Inner Flue Gasket
39	010/MR126 100mm Spigot Assy
40#	004/BT024 Facia Plate
41	004/GR090 Fastener Retainer
42	008/FFW007 M8 Washer
43	010/XR085 Roller
44	008/FFP006 R-Pin
45	010/BT043 Upper Hinge Spacer
46	010/XR041 Upper Hinge Bracket
47	010/XR042 Hinge Spacer
48	012/BT011 Serial No Label
49	010/XR088 Ash Scoop

* These items are not shown in the drawing
Please specify the colour when ordering

To obtain spare parts please contact your local stockist giving Model, Part No. and Description. In case of difficulty contact the manufacturer at the address shown. This drawing is for identification purposes only.

Bay 5GT Parts List

Issue E

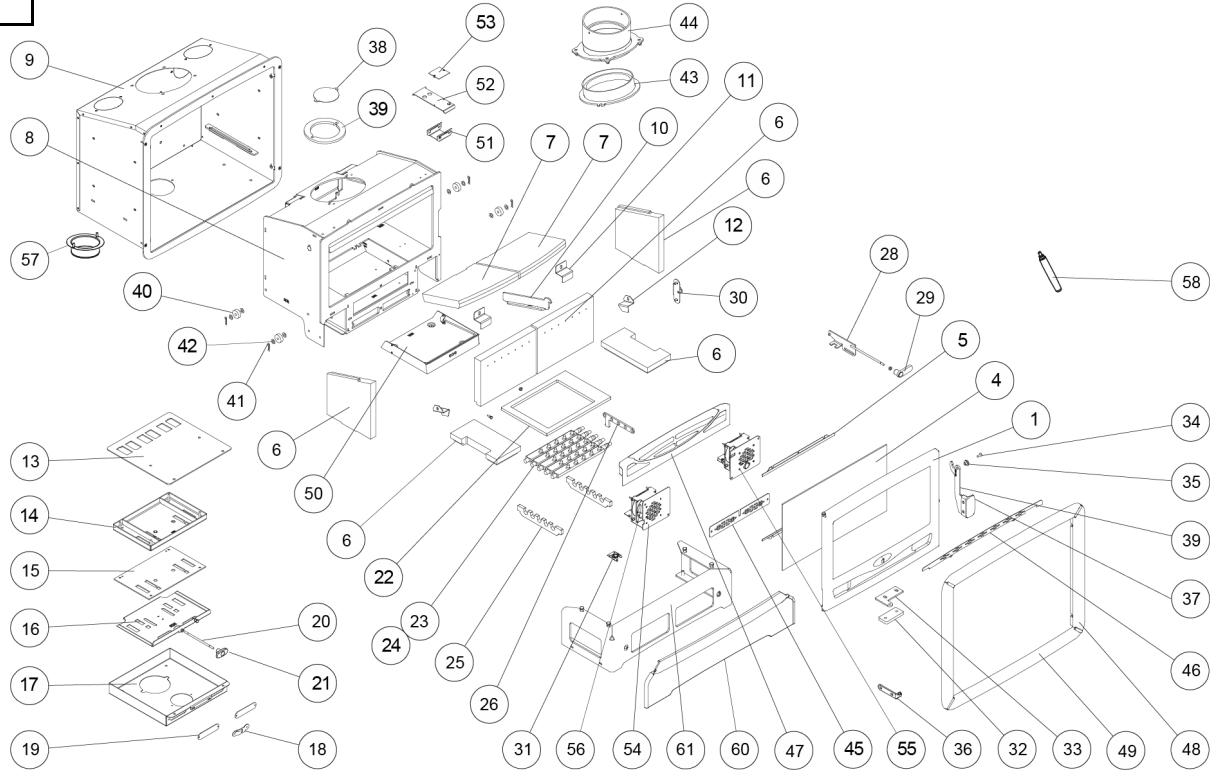

Item	Part No.	Description	Item	Part No.	Description
1#	002/MR001/A	Door Assembly	32	010/MR025	Hinge Spacer
2*	008/MR085	Glass Seal	33	010/MR026	Upper Hinge Bracket
3*	008/MR086	Door Seal	34	008/FFS018	6x12 CSK Allen Screw
4	006/MR019	Glass	35	008/MR047	Handle Pivot Boss
5	004/XR074	Glass Retainer	36	002/XR020	Lower Hinge Bracket
6	011/MR0285	Set of Side, Back & Base Bricks	37	010/MR038	Door Handle Assembly
7	011/MR0315	Set of Baffle Firebricks	38	004/CR064	Duct Coverplate
8	001/MR010	Firebox	39	008/MR091	Inlet Gasket
9	010/MR011	Convection Casing	40	010/XR085	Roller
10	010/MR087	Throat Plate Support Bracket	41	008/FFP006	'R' Clip
11	004/XR008	Brick Bracket Rear	42	008/FFW007	M8x17 Washer
12	004/XR025	Brick Bracket Side	43	010/XR098	6" Lower Flue Adaptor
13	008/MR106	Airbox Gasket	44	010/XR096	6" Upper Flue Adaptor
14	010/MR095	Airbox	45	004/MR105	Lower Grill
15	010/MR005	Air Control Plate	46	004/MR027	Top Screen
16	004/MR007	Air Slide Control	47	002/MR017	Fence
17	004/MR097	Airbox Cover	48#	002/MR112	Side Trim
18	004/BR009	Seal Retainer	49#	002/MR113	Top/Bottom Trim
19	004/MR098	Air Inlet Cover	50	004/MR016	Ashpan
20	008/KS124	Air Control Rod	51	004/MR115	Serial No Bracket
21	002/MR067	Air Control Knob	52	004/MR116	Serial Plate Carrier
22	010/MR024	Grate Cover Plate	53	012/MR014	Serial No Label
23	002/CG0155	Set of Grate Bars (5)	54	010/MR096	LH Fan Assembly
24	002/CG01	Bottom Grate Bar	55	010/MR093	RH Fan Assembly
25	010/MR022	Carrier Bar	56	008/MR099	Fan
26	010/MR023	Mover Bar	57	010/MR126	100mm Spigot Assy
28	010/MR051	Riddler Assembly	58	008/PX95	Ashpan Tool
29	002/MR069	Riddler Handle	59*	008/TH08	Charnwood Gloves
30	004/MR044	Latch	60#	002/MR114	Lower Fireplace Trim (Optional Extra)
31	004/MR110	Thermal Switch Mounting	61	010/XR093	Fireplace Stand (Optional Extra)

*These items are not shown on the drawing.
Please specify colour when ordering.

To obtain spare parts please contact your local stockist giving Model, Part No. and Description. In case of difficulty contact the manufacturer at the address shown. This drawing is for identification purposes only.

charnwood 



A.J WELLS & SONS LTD

Bishops Way, Newport, Isle of Wight PO30 5WS, United Kingdom
A Division of A.J.Wells & Sons Limited Registered in England No. 03809371

EN13229:2001/A2:2004/AC:2007

**INSET APPLIANCES INCLUDING OPEN FIRES
FIRED BY SOLID FUELS**

Model	Bay 5GT	Bay 5
EC Certificate of conformity no:	MR-CPD-2015	XR-CPD-2015
Fuel type:	WOOD LOGS	WOOD LOGS
Emission of CO in combustion products:	0.08%	0.10%
Mean flue gas temperature:	286°C	279°C
Space heating thermal output:	5.8kW	5.0kW
Energy efficiency	80%	81%
Minimum distance to combustibile materials:		
Casing Side:	100mm + 100mm insulation	100mm + 80mm insulation
Casing Rear:	100mm + 100mm insulation	100mm + 80mm insulation
Room, side:	150mm	190mm
Room, above:	460mm	350mm
Room, in front of glass	1000mm	900mm

charnwood

A.J WELLS & SONS LTD
Bishops Way, Newport, Isle of Wight PO30 5WS, United Kingdom
A Division of A.J.Wells & Sons Limited Registered in England No. 03809371

EN16510-1:2022/ EN16510-2-2:2022

INSET ROOMHEATER

Model	Bay 5VL
EC Certificate of conformity no:	BT-CPD-2015
Fuel type:	WOOD LOGS
Rated space heating thermal output:	5.0kW
NOX (mg/Nm ³)	105
OGC (mg/Nm ³)	118
CO (mg/Nm ³)	1250
Mean flue gas temperature:	279°C
Energy efficiency	81%
Minimum distance to combustible materials:	
Casing Side:	100mm + 80mm insulation
Casing Rear:	100mm + 80mm insulation
Room, side:	190mm
Room, above:	350mm
Room, in front of glass	900mm

All product related data available here:

<https://www.charnwood.com/conformance-documentation>

your premier dealer

charnwood BISHOPS WAY, NEWPORT, ISLE OF WIGHT PO30 5WS, UNITED KINGDOM
T:+44 (0)1983 537777 • F:+44 (0)1983 537788 • CHARNWOOD@AJWELLS.CO.UK • WWW.CHARNWOOD.COM

