



cranmore

3 • 5 • 7

Operating & Installation Instructions

CONTENTS

QUICK GUIDE	4
OPERATING INSTRUCTIONS	5
FUEL	5
LIGHTING	5
CONTROLLING THE FIRE	5
REFUELLING	6
ASH CLEARANCE	6
REDUCED BURNING	6
MAINTENANCE	6
THROAT PLATE AND FLUEWAY CLEANING	7
CHIMNEY SWEEPING	7
TROUBLE SHOOTING	8
CO ALARM	9
IF YOU NEED FURTHER HELP	9
INSTALLATION INSTRUCTIONS	10
SPECIFICATION	10
UNPACKING THE STOVE	10
HEALTH AND SAFETY PRECAUTIONS	10
CO ALARMS	10
CHIMNEY	10
HEARTH AND FIRE SURROUND	11
CONNECTIONS TO FLUES	11
SOOT DOORS	12
PRE LIGHTING CHECK	12
COMMISSIONING	12
CAA AND SMOKE CONTROL	13
COOKING PLATE	13
CRANMORE 3 DIMENSIONS	14
CRANMORE 5 DIMENSIONS	15
CRANMORE 7 DIMENSIONS	16
CRANMORE 3 PARTS LIST	17
CRANMORE 5 PARTS LIST	18
CRANMORE 7 PARTS LIST	19
CE CERTIFICATE	20

QUICK GUIDE

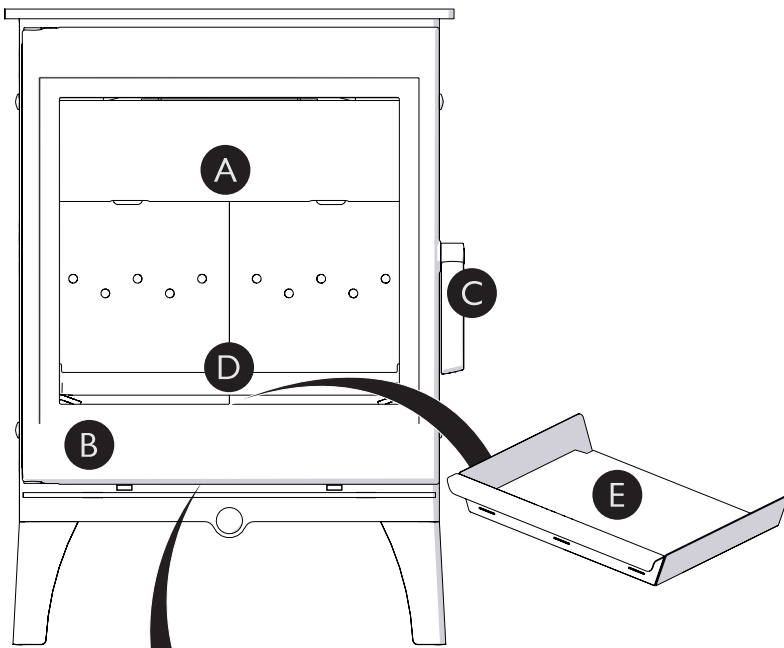

- A Throat plate**
Improves efficiency of stove by slowing down flue gases
- B Door**
Keep closed when stove is in use
- C Door handle**
Pull to open
- D Front Fence**
Protects glass and prevents spillage
- E Sliding Ashpan**
For clean and easy ash removal

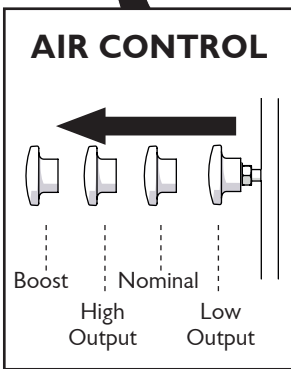

MAINTENANCE AND CLEANING

GLASS

Wipe with damp, lint free cloth. Any stubborn deposits on the glass may be removed with a proprietary stove glass cleaner or ceramic hob cleaner.

THROAT PLATE & UPPER BAFFLE

Take down once a month and clean. Sweep sooty deposits into fire

CHIMNEY

Have chimney swept twice a year. Chimney can be swept through stove.

SERVICING

Stove should be serviced by a professional at least once a year.

LIGHTING AND CONTROLLING THE FIRE

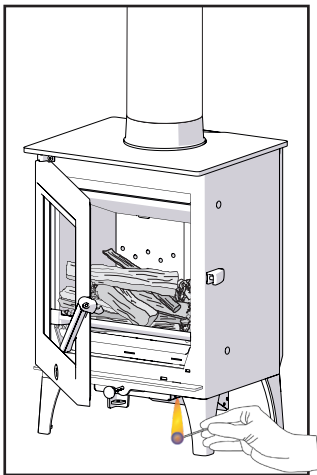

Add kindling and paper or firelighters. Keep air control fully out and door cracked open.

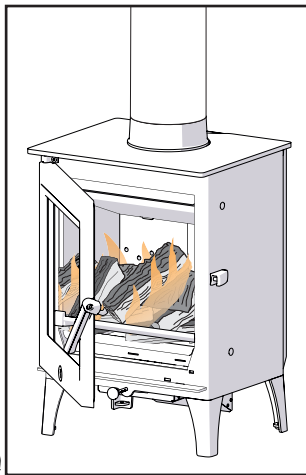

Once kindling is alight, add smaller logs. Keep air control fully out and close door.

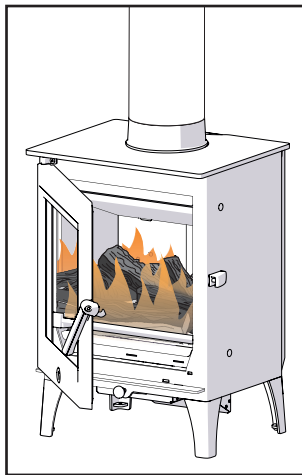

Add larger logs once fire is established. Air control can be reduced to minimum.

Suitable fuels for your

Charnwood:
Wood logs

Unsuitable fuels:

Petroleum coke
Liquid fuel
Household waste
Coal singles
Small nuts or coal dust
Wet or unseasoned wood
Smokeless mineral fuel



Congratulations on becoming the owner of a Charnwood Cranmore Stove. Your stove has been approved in smoke control areas to burn wood logs if it is used in accordance with these instructions. It is very important that you read and understand these instructions before using the stove.

Before lighting the stove check with the installer that the work and checks described in the Installation Instructions have been carried out correctly and that the chimney has been swept, is sound and free from any obstructions. The stove is not suitable for use in a shared flue system.

If you are using your stove to burn wood logs in a smoke controlled area, then the provided Defra Stop **MUST** be fitted and the instructions on lighting and refuelling **MUST** be followed. This stove will not produce significant smoke if well seasoned logs of less than 20% moisture content are burnt and these instructions are adhered to. Burning wet (>20% moisture content) wood and operating the stove in an irresponsible manner may produce smoke which is illegal in smoke controlled areas.

Remember that the stove will be hot and that it is made from hard materials – ensure that you have good balance before operating the fire. Always use the provided operating tool and gloves.

Do not use an aerosol spray on or near the stove when it is alight. There is a risk of explosion or flash ignition of the spray.

When using the stove in situations where children, aged and/or infirm persons are present a fireguard must be used to prevent accidental contact with the stove. The fireguard should be manufactured in accordance with BS 8423:2002.

The stove is suitable for intermittent operation.

FUEL

This stove has been designated to burn wood. Only dry well seasoned wood should be burnt on this appliance as burning wet unseasoned wood will give rise to heavy tar deposits in the stove, on the glass and within the chimney. For the same reason hard woods (such as Ash, Beech and Oak) are better than soft woods (such as Pine and Spruce). Burning wet unseasoned wood will also result in considerably reduced outputs. The wood should be cut and split and then left to season in a well ventilated dry place for at least one year but preferably two years before use.

Approximate suitable log sizes are:

244mm(10in) long and 75mm (3in) diameter - Cranmore 3
300mm(11in) long and 75mm (3in) diameter - Cranmore 5
390mm(15in) long and 75mm (3in) diameter - Cranmore 7

Log moisture content of less than 20% is recommended.

PETROLEUM COKE IS NOT SUITABLE FOR USE ON THIS APPLIANCE. ITS USE WILL INVALIDATE THE GUARANTEE.

This stove is not designed to burn household waste.

LIGHTING

On initial lighting, the stove may smoke and give off an odour as the silicon paint with which the firebox is painted reacts to the heat. This is normal and will cease after a short time, but meanwhile the room should be kept well ventilated.

At first only light a small fire and burn it slowly for two hours to allow any residual moisture in the chimney to evaporate.

Light the stove using dry kindling wood and paper or fire lighters. Put the paper, or fire lighters, and kindling in the firebox and cover with a few small dry logs. Open the air controls – the primary air control in the door and the airwash control - fully (see Fig. 1) Light the paper or fire lighters. The door may be left cracked open for a few minutes to assist the combustion and heat up the firebox more quickly. When the kindling wood is well alight add a few more small logs, close the door but leave the air control fully open. When the flames are established around these logs, load the stove with the required fuel load. Maintain the air control at maximum at this stage. Once the fire is up to temperature the airwash system will begin to work, so allow the fire to become hot before adjusting the air control to the required setting. During the lighting period, do not leave the stove unattended. Do not leave the door open except as directed above to avoid excessive smoke.

When relighting the stove, leave the ash on the base, unless it is becoming too deep, in which case some of it may be removed.

CONTROLLING THE FIRE

The rate of burning and hence the output is controlled by the air control (see Fig.1)

Open the air control fully (boost position) when lighting or when rapid burning is required. It should not be left fully open for long



periods as this can cause over-firing or excessive smoke production. For high output move the air control to the 'click position' or for low burning to the fully closed position.

When the fire is burning normally the air control gives enough airwash to keep the glass clean. However, it will not always be possible to keep the glass clean with the air control fully closed. For correct firing we recommend the use of a stove pipe thermometer which may be purchased from your supplier or from Charnwood.

The Charnwood Cranmore 3, Cranmore 5 and Cranmore 7 is fitted with an air control stop for use in a smoke control area. This stops the stove from burning too slowly.

Fig. 1 Stove controls

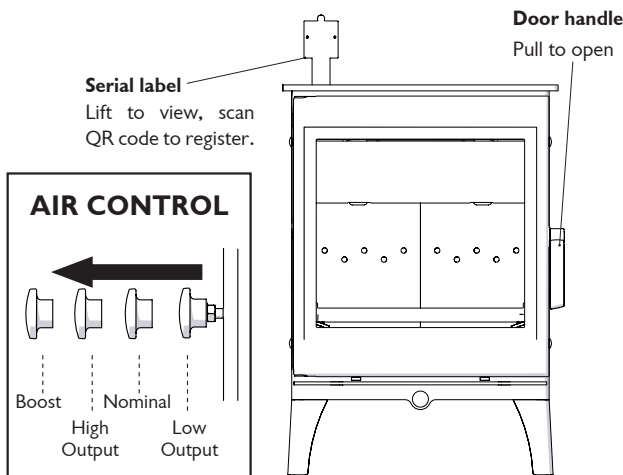

REFUELLING

Keep the firebox well filled but do not allow fuel to spill over the top of the fuel retainer.

Logs should be evenly distributed, filling the firebed to give the most pleasing flame pattern. The air control must be fully opened after refuelling until the flames are established above the fire. It is best to refuel on to a hot bed of embers. If at this point the fire starts to die, the door must be cracked open until the fire is revived. If the fire has started to die down before refuelling, then more kindling wood must be added, the air control opened fully and the door cracked open to re-establish the firebed before adding larger logs (see suitable log sizes in Fuel section). This will avoid excessive smoke emission.

Care should be taken, especially when burning wood, that fuel does not project over the fuel retainer or damage to the glass may be caused when the door is closed. It can also cause the glass to blacken up. Maximum filling height is such that logs cannot fall from the fire

when the door is opened.

In smoke controlled areas do not fill the stove above the level of the air holes in the back bricks, as overloading can cause excess smoke.

Do not operate with the door open except as directed by the instructions as this can cause excessive smoke.

ASH CLEARANCE

Before removing ash ensure that it has cooled down. The ashpan slides out for easy ash removal.

To make ash removal easier there are ash carriers available. These may be purchased from your supplier or, in case of difficulty, from Charnwood.

REDUCED BURNING

For reduced burning the fire door must be closed.

When burning wood in areas that are not smoke controlled, load some large logs on the fire and allow to burn for half an hour before closing the air control (this will help to reduce tar deposits in the chimney). Some experimentation may be necessary to find the setting most suitable for the type of fuel being used and the draw on the chimney.

MAINTENANCE

Cleaning

The stove is finished with a high temperature paint which will withstand the temperatures encountered in normal use. This may be cleaned with a damp lint-free cloth when the stove is cold. Should re-painting become necessary, high temperature paints are available from your supplier or from stove shops.

Cleaning the Glass

Most deposits on the glass may be burnt off simply by running the fire at a fast rate for a few minutes. If it becomes necessary to clean the glass then open the door and allow it to cool. Clean the glass using a damp cloth and then wiping over with a dry cloth. Any stubborn deposits on the glass may be removed with a proprietary stove glass cleaner or ceramic hob cleaner. Do not use abrasive cleaners or pads as these can scratch the surface which will weaken the glass and cause premature failure

When Not in Use

If the fire is going to be out of use for a long period (for instance in



the summer) then to prevent condensation, and hence corrosion, the air control should be left fully open and the fire door left ajar. It is also advisable to sweep the chimney and clean out the fire. Spraying the inside of the door with a light oil, such as WD40, will also help to keep all internal parts working well. After long periods where the fire has been out of use, the chimney and appliance flueways should be cleaned before lighting.

Door Seals

For the fire to operate correctly it is important that the door seals are in good condition. Check that they do not become worn or frayed and replace them when necessary.

Servicing

It is recommended that the fire is serviced once a year to keep it in first class working order. After cleaning out the firebox thoroughly, check that all internal parts are in good working order, replacing any parts that are beginning to show signs of wear. Check that the door seals are in good condition and that the doors seal correctly. A servicing guide is available on request. Repairs or modifications may only be carried out by the Manufacturer or their approved agents. Use only genuine Charnwood replacement parts.

THROAT PLATE AND FLUEWAY CLEANING

It is important that the throat plate and all the stove flueways are kept clean in order to prevent potentially dangerous fume emission. They should be cleaned at least monthly, and more frequently if necessary. It is necessary to let the fire out to carry out these operations.

To remove the throat plate, first remove the fuel retainer (item 'e' page 4) and one side plate to allow enough room so that the throat plate clears the sides of the fire box when removed.

The Cranmore 7 throat plate is made up of two bricks and a bracket that slides over the front that holds the two bricks together. The Cranmore 3 & 5 throat plate is one brick.

To remove the throat plate, if made up of two pieces, first carefully remove the joining bracket at the front of the throat plate and then lift the two pieces down from the top of the stove. If the throat plate is a single piece, slide the throat plate forwards so that it clears the back brick, then slide it either right or left so that the opposite side clears the top of the remaining side brick and can be gently lowered. Any sooty deposits should then be swept from the throat plate and into the fire.

On Cranmore 5 & 7 models only, lift out the upper throat plate that rests centrally on top of the air wash tubes and clean any deposits,

then re-fit it as shown in figure 2 by locating it into the hook at the top of the front of the firebox.

To re-fit the lower throat plate, if the throat plate is made up of two pieces, fit each half so that it rests on the side and back brick, then, making sure the two halves are fitted closely together, slide the joining clip back onto the front edge, making sure that it is central on the join. If it is a single piece, return the throat plate to its correct position by offering up the throat plate at an angle. Insert the throat plate so that it sits on top of either the right or left side brick. Raise the opposite side and slide so that the throat plate is central and supported by the side bricks. Slide back so that the throat plate rests neatly on the top of the back bricks. Refit the remaining side plate.

Fig.2 Throat Plate Location

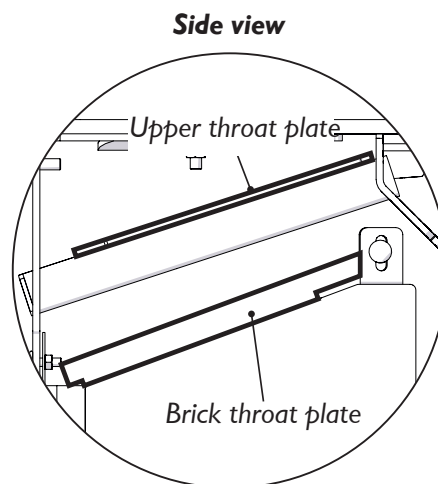

CHIMNEY SWEEPING

Where the chimney previously served an open fire, it is possible that the higher flue gas temperature from a stove may loosen soot deposits with the consequent risk of flue blockage. It is therefore recommended that the chimney be swept a second time within a month of regular use after installation.

The chimney should be swept at least twice a year. Where the top outlet or vertical rear flue connector is used it will generally be possible to sweep the chimney through the appliance.

First remove the upper and lower throat plates. Then sweep the chimney ensuring that soot is removed from all horizontal surfaces after sweeping.

In situations where it is not possible to sweep through the appliance the installer will have provided alternative means, such as a soot



door. After sweeping the chimney the appliance flue outlet and the flue pipe connecting the stove to the chimney must be cleaned with a flue brush.

After clearing any soot from within the stove, replace the throat plate (see Fig. 2).

Different types of sweep's brushes are available to suit different flueways. For prefabricated insulated chimneys the manufacturers instructions with regard to sweeping should be consulted.

TROUBLE SHOOTING

Fire Will Not Burn

Check that:

- a) the air inlet is not obstructed in any way,
- b) chimneys and flueways are clear,
- c) a suitable fuel is being used,
- d) there is an adequate air supply into the room,
- e) If an extractor fan is fitted, that it is not causing lack of flue draft when operating.
- f) there is sufficient draw in the chimney. Once the chimney is warm a draught reading of at least 1.25 mm (0.05 in.) water gauge (12Pa) should be obtained.

Blackening of Door Glass

Differences in chimney draughts mean that the best settings of the air controls will vary for different installations. A certain amount of experimentation may be required, however the following points should be noted and with a little care should enable the glass to be kept clean in most situations:

- a) Wet or unseasoned wood, or logs overhanging the front fence will cause the glass to blacken.
- b) The airwash relies on a supply of heated air to keep the glass clean, therefore, when lighting the stove allow the firebed to become well established before closing the air control. This may also be necessary when re-fuelling the stove.
- c) When re-fuelling keep the fuel as far back from the front fence as possible, do not try to fit too much fuel into the firebox
- d) Do not completely close the air control.

It is always more difficult to keep the glass clean when running the stove very slowly for long periods.

If blackening of the glass still occurs check that all flue connections and the blanking plate are well sealed. It is also important that the chimney draw is sufficient and that it is not affected by down-draught. When the chimney is warm a draught reading of at least 1.25 mm (0.05 in.) water gauge (12Pa) should be obtained. Some blackening of the glass may occur below the level of the fuel retainer. This will not obscure the view of the fire or affect its performance.

Fume Emission

Warning Note: Properly installed and operated this appliance will not emit fumes. Occasional fumes from de-ashing and re-fuelling may occur. Persistent fume emission is potentially dangerous and must not be tolerated. If fume emission does persist, then the following immediate actions should be taken:

- a) **Open doors and windows to ventilate the room and then leave the premises.**
- b) **Let the fire out and safely dispose of the fuel from the appliance.**
- c) **Check for flue or chimney blockage, and clean if required.**
- d) **Do not attempt to re-light the fire until cause of fuming has been identified, if necessary seek professional advice.**

The most common cause of fume emission is flueway or chimney blockage. For your own safety these must be kept clean.

Fire blazing out of control

Check that:

- a) The door is tightly closed.
- b) The air control slider is fully closed.
- c) A suitable fuel is being used.
- d) Door seals and air slide are intact.

Chimney Fires

If the chimney is thoroughly and regularly swept, chimney fires should not occur. However, if a chimney fire does occur close the air control, and tightly close the door of the appliance. This should cause the chimney fire to go out in which case the controls should be kept closed until the stove has gone out. The chimney and flueways should then be cleaned. If the chimney fire does not go out when the above action is taken then the fire brigade should be called immediately. After a chimney fire the chimney should be carefully examined for any damage. Expert advice should be sought if necessary.



CO ALARM

Your installer should have fitted a CO alarm in the same room as the appliance. If the alarm sounds unexpectedly, follow the instructions given under “Warning Note” above.

IF YOU NEED FURTHER HELP

If you need further help with your Charnwood then your Installer will be able to provide the answers to most questions. Your Local Charnwood Premier Dealer has a great deal of experience and will also be able to provide helpful advice. Further help is available from the Charnwood Customer Services department who will be pleased to give advice, if necessary.

INSTALLATION INSTRUCTIONS



SPECIFICATION	CRANMORE					
	3		5		7	
Fuel	Wood logs		Wood logs		Wood logs	
Rated Heat Output kW (BTU/hr)	3.7		5.0		7.0	
Model weight kg (Packed)	62		91.5		101.5	
Flue Temperature °C	217/217		230		256	
Minimum Flue Draught	12Pa		12Pa		12Pa	
Flue gas Mass Flow g/s	3.1		4.4		6.3	
Hearth Temperature	<100		<100		<100	
Minimum distance from combustibles mm	SIDE	BACK	SIDE	BACK	SIDE	BACK
With single wall flue:	310	250	350	350	420	360
With insulated flue and heatshield:	310	100	350	100	390	110
<i>The outputs in the table are based on a 45 minute re-fuelling cycle burning seasoned hardwood logs. All tests are carried out in accordance with BSEN 13240.</i>						

UNPACKING THE STOVE

The stove arrives bolted and strapped to its pallet. There must be adequate facilities for unloading and manoeuvring into position. The wrapping is first removed, then the stove released from the pallet by removing 4 pallet bolts using a 10mm spanner. The pallet brackets can now be removed from the stove by tilting it and using a 13mm spanner to remove the bolts. The pallet is intended to be cut up and used for kindling fuel.

HEALTH AND SAFETY PRECAUTIONS

Please take care when installing the stove that the requirements of the Health and Safety at Work Act 1974 are met.

Some types of fire cement are caustic and should not be allowed to come into contact with the skin. In case of contact wash with plenty of water.

If there is a possibility of disturbing any asbestos in the course of installation then please use appropriate protective equipment.

Ideally there should not be an extractor fan fitted in the same room as the appliance. If this situation is unavoidable then specialist advice should be taken to ensure that the extractor fan does not cause the appliance to emit fumes into the room. The external air kit will help with this in some situations. Alternatively, an additional air supply correctly positioned may be necessary. It is essential to carry out a spillage test to ensure that the appliance can operate safely when the extractor fan is operating.

There must be an adequate air supply into the room in which the appliance is installed to provide combustion air. The combustion air supply must be via a permanently open vent. The requirement for minimum free area is partly dependent on the design air permeability of the house. In older properties the air permeability will be above 5.0m³/(h.m²), but in some modern properties it may be less. The vent must be positioned such that it is not liable to blockage. Minimum areas are given in the following table:

AIR PERMEABILITY m ³ /(h.m ²)	MINIMUM VENT AREA cm ² (in ²)		
	CRANMORE		
	3	5	7
>5.0	No requirement	No requirement	11 (1.76)
<5.0	27.5 (4.3)	27.5 (4.3)	38.5 (6.0)

A fixed ducted air supply may be used as an alternative to the traditional method of using a permanent open vent into a room to supply air for combustion.

External air supply kits are available please contact Charnwood for more information. Instruction sheet ref: TIS 120

This stove is capable of intermittent operation, and is not suitable for use in a shared flue system.

In addition to these instructions the requirements of BS.8303 and BSEN 15287-1:2007 must be fulfilled. Local Authority Bylaws and Building Regulations, including those referring to national and European Standards, regarding the installation of Solid Fuel burning appliances, flues and chimneys must also be observed.

CO ALARMS

Building regulations require that whenever a new or replacement fixed solid fuel or wood/biomass appliance is installed in a dwelling a carbon monoxide alarm must be fitted in the same room as the appliance. Further guidance on the installation of the carbon monoxide alarm is available in BS EN 50292:2002 and from the alarm manufacturer's instructions. Provision of an alarm must not be considered a substitute for either installing the appliance correctly or ensuring regular servicing and maintenance of the appliance and chimney system.

CHIMNEY

In order for the appliance to perform satisfactorily the chimney must give sufficient draw when warm (minimum of 12pa/0.05"



wg). The height of the chimney must comply with local building regulation requirements. The internal dimensions of the chimney **MUST NOT BE LESS THAN 125 mm (5")** - Cranmore 3, 150mm (6") - Cranmore 5 and Cranmore 7.

If an existing chimney is to be used it must be swept and checked, it must be in good condition, free from cracks and blockages, and should not have an excessive cross sectional area. If it was previously used by an open fire then the chimney should be swept one month after installation to clear any soot falls which may have occurred due to the difference in combustion between the stove and the open fire. If you find that the chimney is in poor condition then expert advice should be sought regarding the necessity of having the chimney lined. If it is found necessary to line the chimney then a lining suitable for Solid Fuel must be used.

If there is no existing chimney then a prefabricated block chimney or a twin walled insulated stainless steel flue to BSEN 15287-1:2007 can be used either internally or externally. These chimneys must be fitted in accordance with the manufacturers instructions and Building Regulations.

Single wall flue pipe is suitable for connecting the stove to the chimney but is not suitable for using for the complete chimney. If it is found that there is excessive draw in the chimney then a draught stabiliser should be fitted.

It is important that there is sufficient draw in the chimney and that the chimney does not suffer from down-draught. When the chimney is warm the draw should be not less than 1.25mm (0.05") water gauge (12 Pa). If in doubt about the chimney seek expert advice.

HEARTH AND FIRE SURROUND

The stove must stand on a fireproof hearth and must not be situated closer than the minimum distance from combustible materials (see specification table) to the sides or rear above hearth level unless adequately fireproofed in accordance with local building regulations. The hearth must be of fireproof material and at least 12mm (1/2in.) thick. The positioning of the stove and the size of the hearth are governed by building regulations for Class 1 appliances. These building regulations state that the hearth must extend in front of the stove by at least 225mm (9 in.) and to the sides of the stove by at least 150mm (6 in.). When the fire door is open, it extends beyond the flat front of the stove by 346mm - Cranmore 3, 430mm - Cranmore 5, and 497mm Cranmore - 7.

If in doubt as to the positioning of the stove, expert advice should be

sought either from the supplier or the local building inspector. The fireplace must allow good circulation of air around the appliance to ensure that maximum heat is transferred to the room and also to prevent the fireplace from overheating. A gap of 150mm (6") each side and 300mm (12") above the appliance should give sufficient air circulation. If a wooden mantelpiece or beam is used in the fireplace it should be a minimum of 460mm (18"), and preferably 600mm (24") from the appliance. In some situations it may be necessary to shield the beam or mantelpiece to protect it.

In order for the fire to operate correctly and to allow for access, there must be an air gap behind the appliance of at least 50mm, but be aware that this distance will need to be greater in some cases to meet Building Regulation requirements.

The appliance should be installed on a floor with adequate load-bearing capacity. If an existing construction does not meet this requirement then please take suitable measures to achieve this. (e.g. load distributing plate.)

CONNECTIONS TO FLUES

The Cranmore 5 & Cranmore 7 must be connected to the flue using flue pipe of 150mm (6") diameter, the Cranmore 3 must be connected using flue pipe of 125mm (5") diameter.

If using twin wall flue, the flue collar must be shielded to protect exposed combustible material. This can be done with a shielded starter length of flue.

The flue spigot can be shielded with starter length flue see fig. 3

Fig. 3 Shielding the flue spigot

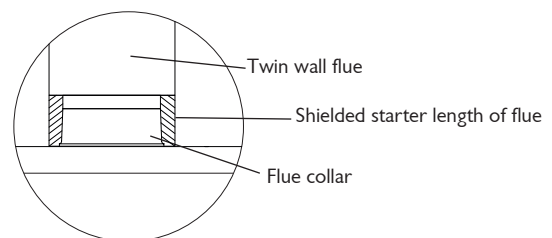

There are several ways of connecting the stove to the flue. These are illustrated in Figs. 5 to 8.

If the top flue connection or optional vertical rear flue connector is used then the chimney may be swept through the appliance.

Horizontal lengths of flue must be kept to a minimum and should not be more in length than the flue diameter.



The stove comes with the blanking plate (fig. 9) fitted to the top flue outlet. The seal for the top outlet is a 155mm dia ring of rope seal. The seal for the rear outlet is a length of adhesive backed fibre webbing supplied with instructions ref: TIS093. This is applied to the flue collar or the Vertical Rear Flue adapter for rear outlet installations. If a Vertical Rear Flue adapter is used on the Cranmore 3 then the 010/AA081 spacer plate is required, this is supplied with the Cranmore 3. For top outlet installations, the blanking plate must be removed, have the webbing fitted to its sealing face, and fitted to the rear flue outlet. Ensure that the fold on the clamping plate is in line with the lugs on the firebox as shown in Fig 9. Ensure that the clamping plate does not prevent the throat plate from seating correctly. All flue connections must be well sealed.

SOOT DOORS

It is possible to pass a 16 inch diameter sweeps brush through the appliance but in most back outlet installations it will be necessary to have a soot door to enable the chimney to be swept. The optional vertical rear flue connector does allow the chimney to be swept through the stove. Soot doors may either be in the actual brickwork of the chimney or in the register plate. Various positions of soot doors are shown in Figs. 5 to 8.

PRE LIGHTING CHECK

Ensure that the throat plate and upper baffle is fitted in the roof of the appliance. For location and positioning see Fig. 2.

Check that the front fence is fitted correctly and that the door closes properly.

COMMISSIONING

On completion of the installation allow a suitable period of time for the fire cement and mortar to dry out before lighting the fire. Make a layer of ash or sand on the base of the stove before lighting. Check to ensure that smoke and fumes are taken from the appliance up the chimney and emitted safely. Also check all joints and seals. On completion of the installation and commissioning please leave the operating instructions with the customer and advise them on the use of the appliance.

Fig. 5 Vertical Register Plate With Bricked Up Fireplace

Soot door inside or rear of chimney

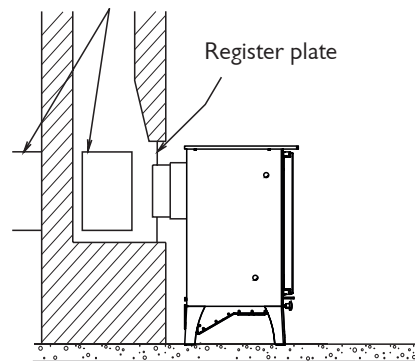

Fig. 6 Horizontal Register Plate With Rear Flue Connection

Alternative soot door positions

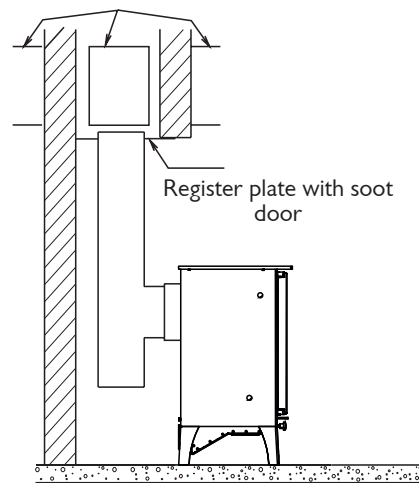

Fig. 7 Horizontal Register Plate With Top Flue Connection

Alternative soot door positions

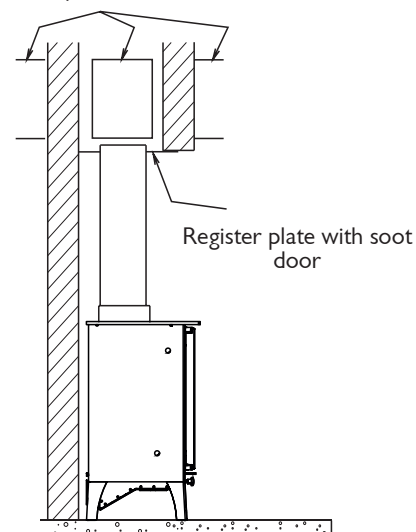
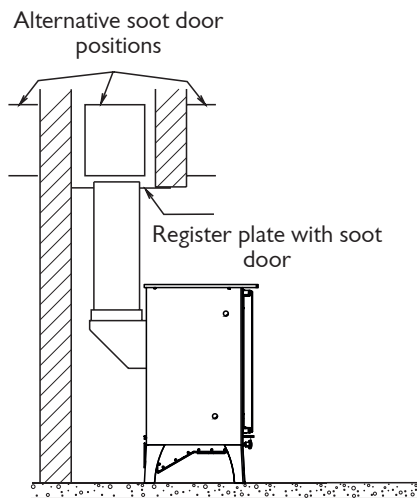



Fig. 8 Horizontal Register Plate With Optional Vertical Rear Flue Connector



CAA AND SMOKE CONTROL

The Clean Air Act 1993 and Smoke Control Areas

Under the Clean Air Act local authorities may declare the whole or part of the district of the authority to be a smoke control area. It is an offence to emit smoke from a chimney of a building, from a furnace or from any fixed boiler if located in a designated smoke control area. It is also an offence to acquire an “unauthorised fuel” for use within a smoke control area unless it is used in an “exempt” appliance (“exempted” from the controls which generally apply in the smoke control area).

In England appliances are exempted by publication on a list by the Secretary of State in accordance with changes made to sections 20 and 21 of the Clean Air Act 1993 by section 15 of the Deregulation Act 2015. Similarly in Scotland appliances are exempted by publication on a list by Scottish Ministers under section 50 of the Regulatory Reform (Scotland) Act 2014.

In Northern Ireland appliances are exempted by publication on a list by the Department of Agriculture, Environment and Rural Affairs under Section 16 of the Environmental Better regulation Act (Northern Ireland) 2016.

In Wales appliances are exempted by regulations made by Welsh Ministers.

Further information on the requirements of the Clean Air Act can be found here: <https://www.gov.uk/smoke-control-area-rules>

Your local authority is responsible for implementing the Clean Air Act 1993 including designation and supervision of smoke control areas and you can contact them for details of Clean Air Act requirements.

The Cranmore 5 Store Stand, Cranmore 5 Low, Cranmore 7 Store Stand and Cranmore 7 Low have been recommended as suitable for use in smoke control areas when burning wood logs. The stove includes a factory-fitted modification to the air control to prevent complete closure of the air supply. Suitable Authorised fuels can also be burned within Smoke Control Areas. A list of Authorised fuels can be found here: <https://smokecontrol.defra.gov.uk/fuels.php>.

Fig. 9. Flue Blanking Plate.

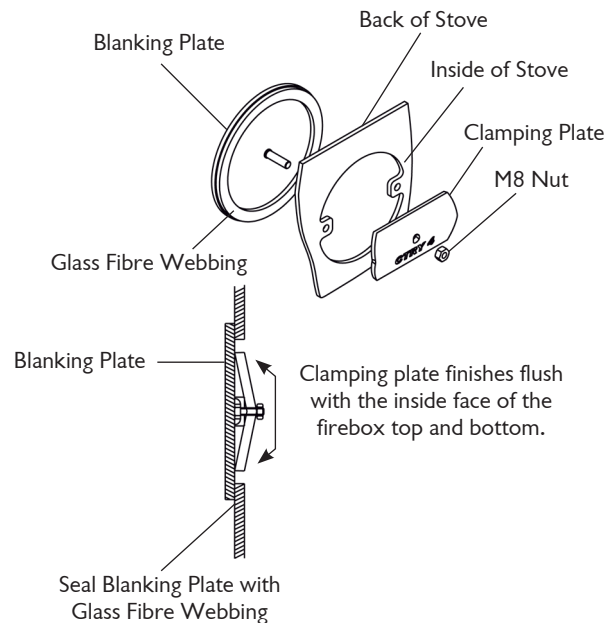

COOKING PLATE

A Cooking plate attachment is available for all Cranmore models:

- 010/BP150S - 6 inch kit used on the Cranmore 5 and Cranmore 7
- 010/AP150S - 5 inch kit used on the Cranmore 3

The kit comprises of a cooking plate and four trivets and can only be fitted to the stove if a rear flue connection is made. The Cranmore 3 is capable of holding only 2 trivets at a time. For more information see sheet REF. TIS136.

CRANMORE 3 DIMENSIONS

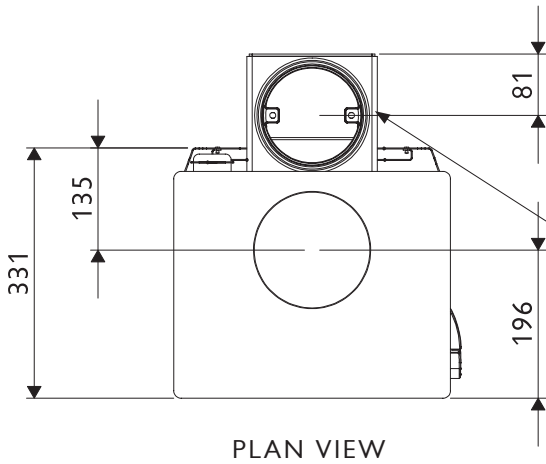

PLAN VIEW

VERTICAL REAR FLUE ADAPTOR

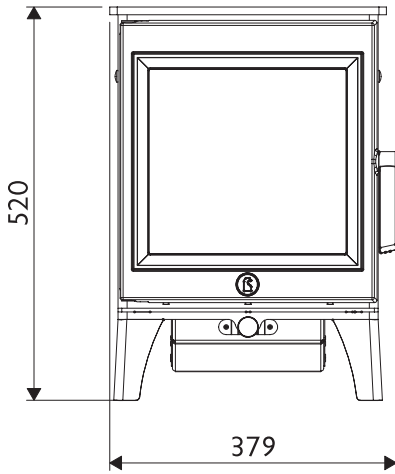

FRONT

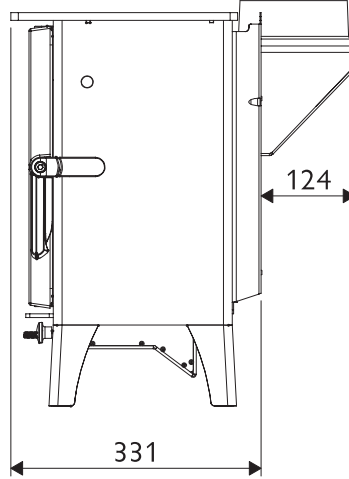

SIDE

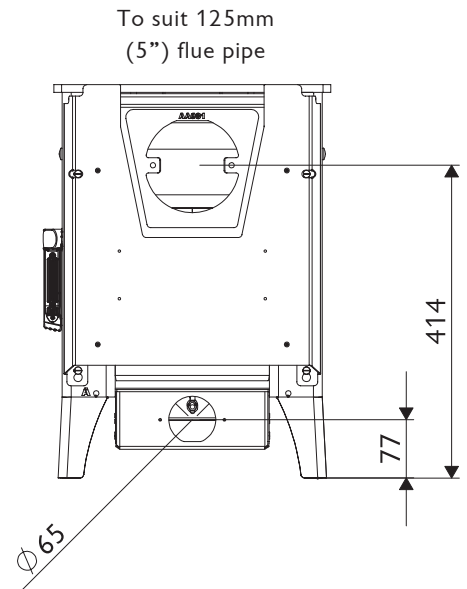

REAR

CRANMORE 5 DIMENSIONS

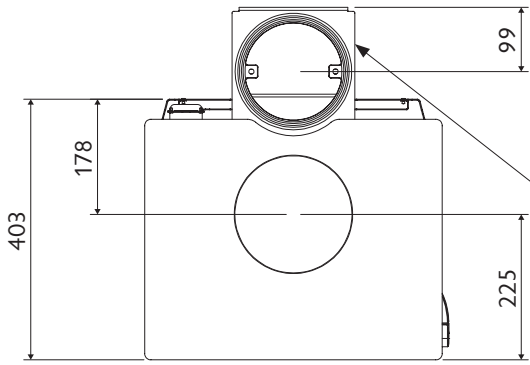

PLAN VIEW

VERTICAL REAR FLUE ADAPTOR

To suit 150mm
(6") flue pipe

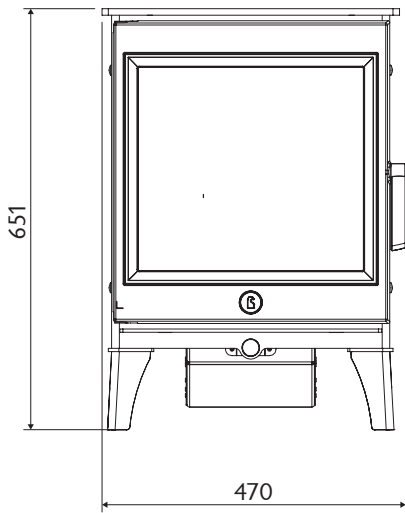

FRONT

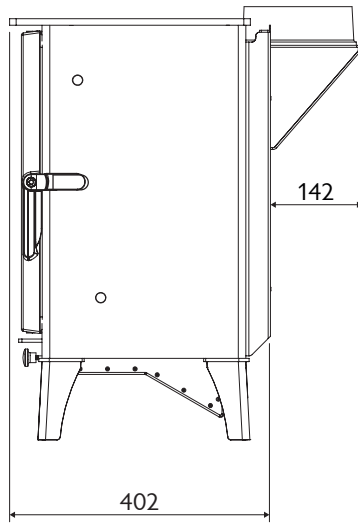

SIDE

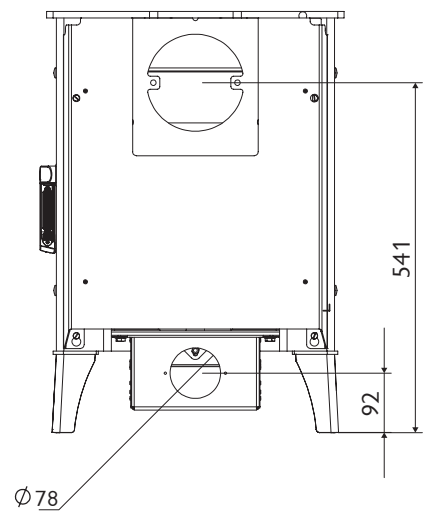

REAR

CRANMORE 7 DIMENSIONS

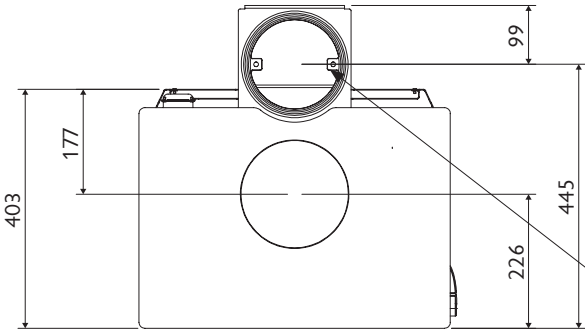

PLAN VIEW

VERTICAL REAR FLUE ADAPTOR

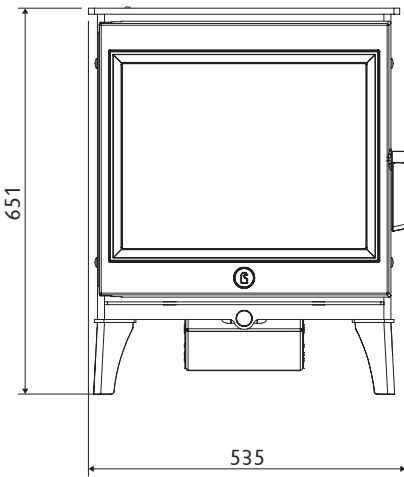

FRONT

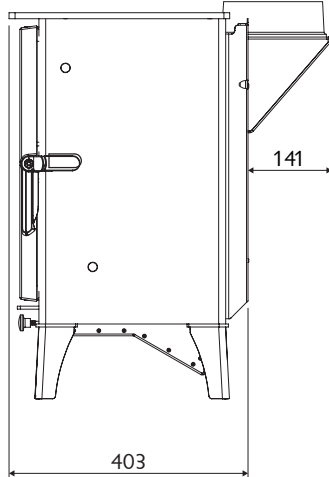

SIDE

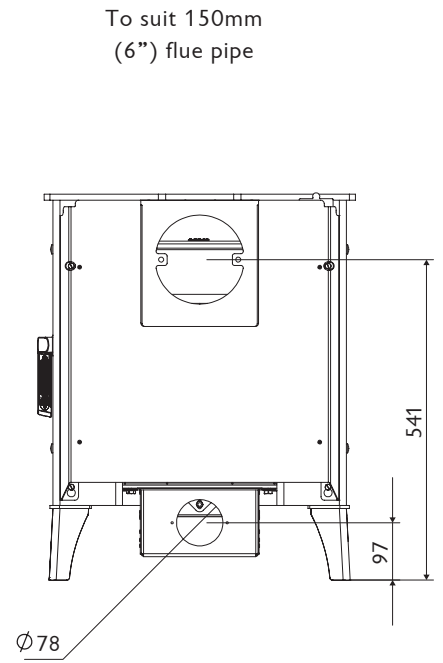

REAR

Charnwood Cranmore 3 Parts List



Issue C

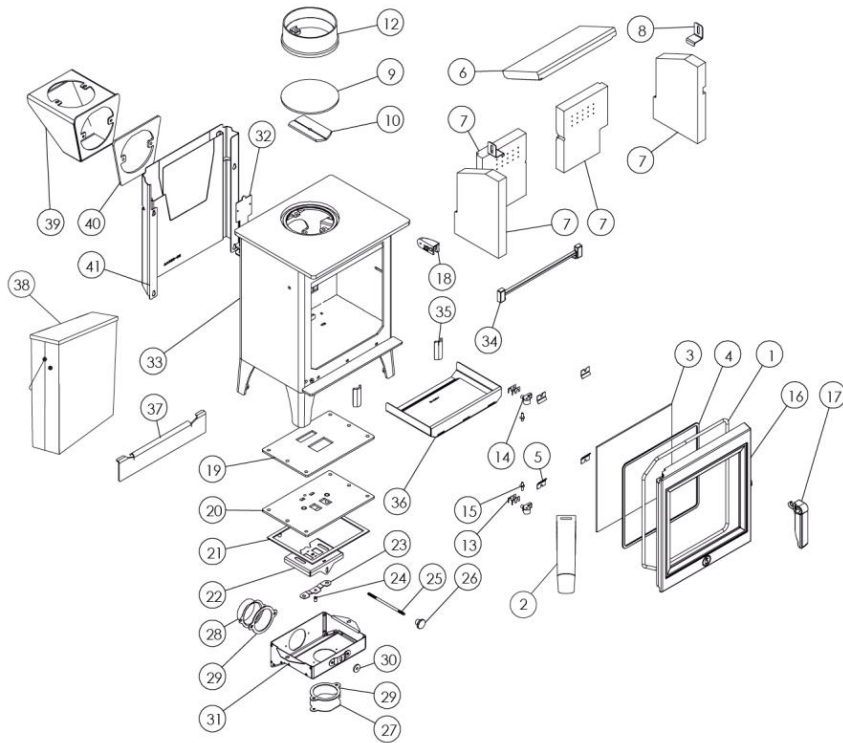

Item	Part No.	Description	Item	Part No.	Description
1	008/LE035	Door Seal (Inc Adhesive)	22	004/AA115	Slider
2*	008/TH085	Door Seal Adhesive	23	004/BR015	Clicker Retainer Plate
3	006/PV19	Glass (Inc Seal)	24	008/ES36/01	Brass Ball Catch
4	008/PV55	Glass Seal	25	004/AA084	Control Rod
5	004/KV23	Glass Retainer	26	008/AY37	Air Control Handle
6	011/AA031	Throat Plate	27	004/BR054	Cover Plate
7	011/AA028S	Set of Fire Bricks	28	004/BR053	Air Inlet Spigot
8	004/XV30	Brick Bracket	29	008/BR044	Air Inlet Gasket
9	012/PV09	Blanking Plate	30	008/BR052	Felt Washer
10	010/EY51	Clamping Plate	31	004/LE040	Airbox Cover
11*	008/EY38	Flue Fixing Rope Seal	32	012/LE011	Serial No. Label
12#	002/PV12B	Flue Collar	33#	001/LE010	Firebox
13	004/BR021	Hinge Shim	34	002/AA008	Front Fence
14	002/BR020	Hinge	35	010/AA009	Fence Support
15	008/ST068/2	Hinge Pin Set	36	004/AA017	Ashpan
16#	003/LE001A	Door Assembly	37	010/AA006	Ash Retainer (Optional Extra)
17#	003/AB012A	Door Handle	38*	010/EW51	Ash Carrier (Optional Extra)
18#	003/AB055A	Latch Receiver	39#	010/BU034	Vert Rear Flue Adaptor (Opt'l Extra)
19	008/LE110	Air Control Gasket	40	010/AA081	Vert Rear Flue Adaptor Spacer
20	010/LE113	Air Control Plate	41#	010/LE080	Heat Shield (Optional Extra)
21	008/LE045	Lower Airbox Gasket			

*These items are not shown on the drawing.
Please specify colour when ordering.

To obtain spare parts please contact your local stockist giving Model, Part No. and Description. In case of difficulty contact the manufacturer at the address shown. This drawing is for identification purposes only.

Charnwood Cranmore 5 Parts List

Issue E

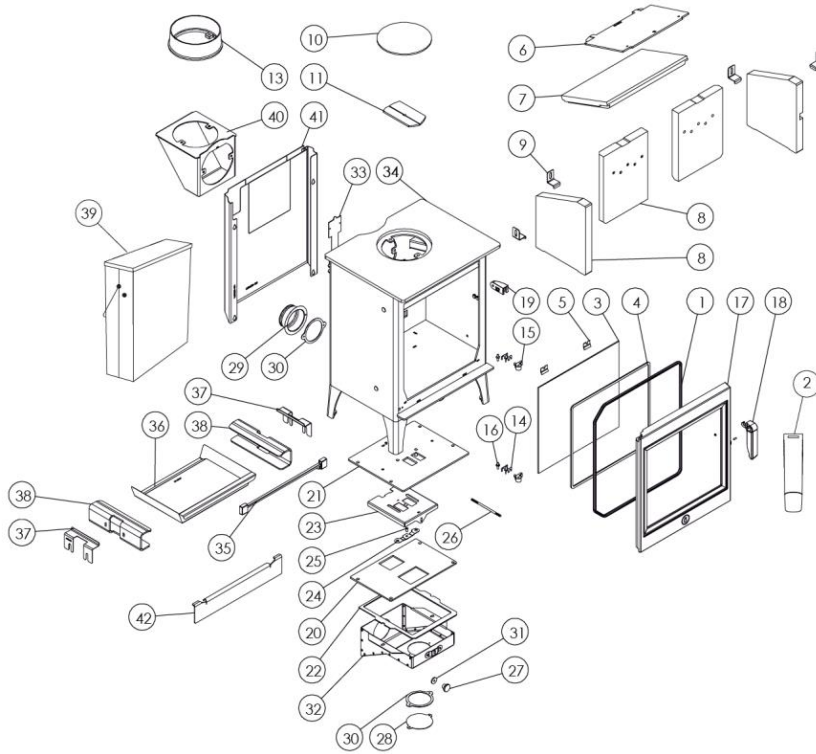

Item	Part No.	Description	Item	Part No.	Description
1	008/AB035	Door Seal (Inc Adhesive)	22	008/LC045	Air Control Cover Gasket
2*	008/TH085	Door Seal Adhesive	23	004/AB115	Slider
3	006/AB018	Glass (Inc Seal)	24	004/BR015	Clicker Retainer Plate
4	008/EW45	Glass Seal	25	008/ES36/01	Brass Ball Catch
5	004/KV23	Glass Retainer	26	004/AA084	Control Rod
6	010/AB045	Upper Throat Plate	27	008/AY37	Air Control Handle
7	011/AB031	Throat Plate	28	004/CR064	Cover Plate
8	011/AB028S	Set of Fire Bricks	29	010/CR048/S	Air Inlet Spigot
9	004/XV30	Brick Bracket	30	008/CR063	Air Inlet Gasket
10	012/TW09	Blanking Plate	31	008/BR052	Felt Washer
11	010/AY51	Clamping Plate	32	004/LC040	Airbox Cover
12*	008/NV38	Flue Fixing Rope Seal	33	012/LC011	Serial No. Label
13#	002/CH12B	Flue Collar	34#	001/LC010	Firebox
14	004/BR021	Hinge Shim	35	002/AB008	Front Fence
15	002/BR020	Hinge	36	004/AB017	Ashpan
16	008/ST068/2	Hinge Pin Set	37	004/AB044	Brick Retainer
17#	003/LC001A	Door Assembly	38	010/AB016	Side Plate
18#	003/AB012A	Door Handle	39*	010/EW51	Ash Carrier (Optional Extra)
19#	003/AB055A	Latch Receiver	40#	010/TW33	Vert Rear Flue Adaptor (Opt'l Extra)
20	008/AB110	Air Control Gasket	41#	010/LC080	Heat Shield (Optional Extra)
21	010/LC130	Air Control Plate	42	010/AB006	Ash Retainer (Optional Extra)

*These items are not shown on the drawing.
Please specify colour when ordering.

To obtain spare parts please contact your local stockist giving Model, Part No. and Description. In case of difficulty contact the manufacturer at the address shown. This drawing is for identification purposes only.

Charnwood Cranmore 7 Parts List



Issue E

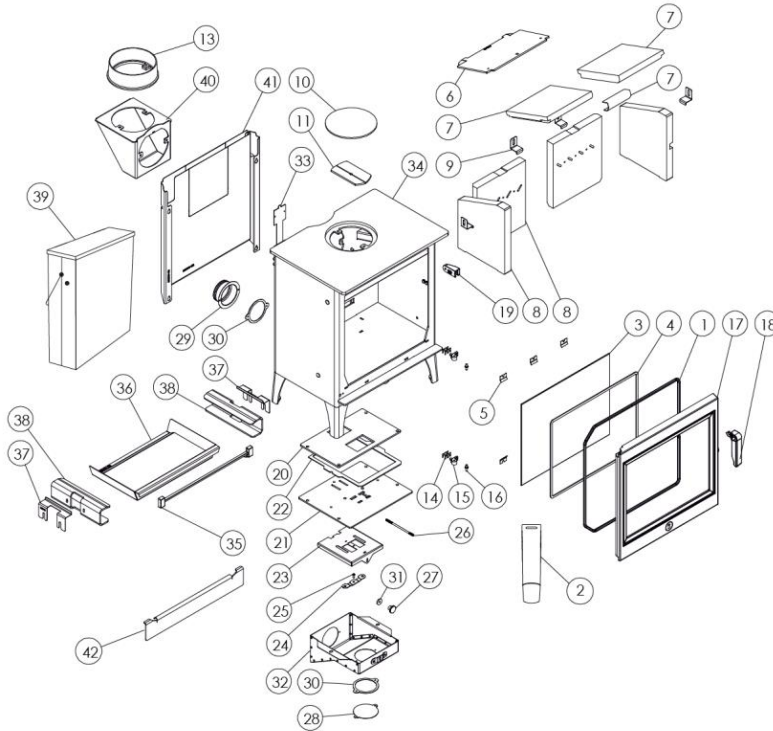

Item	Part No.	Description	Item	Part No.	Description
1	008/AC035	Door Seal (Inc Adhesive)	22	008/LC045	Air Control Cover Gasket
2*	008/TH085	Door Seal Adhesive	23	004/AC115	Slider
3	006/AC018	Glass (Inc Seal)	24	004/BR015	Clicker Retainer Plate
4	008/EW45	Glass Seal	25	008/ES36/01	Brass Ball Catch
5	004/KV23	Glass Retainer	26	004/AA084	Control Rod
6	010/AC042	Upper Throat Plate	27	008/AY37	Air Control Handle
7	011/AC031S	Set of Throat Plate Bricks Inc. Bracket	28	004/CR064	Cover Plate
8	011/AC028S	Set of Fire Bricks	29	010/CR048/S	Air Inlet Spigot
9	004/XV30	Brick Bracket	30	008/CR063	Air Inlet Gasket
10	012/TW09	Blanking Plate	31	008/BR052	Felt Washer
11	010/AY51	Clamping Plate	32	004/LC040	Airbox Cover
12*	008/NV38	Flue Fixing Rope Seal	33	012/LD011	Serial No. Label
13#	002/CH12B	Flue Collar	34#	001/LD010	Firebox
14	004/BR021	Hinge Shim	35	002/AC008	Front Fence
15	002/AC020	Hinge	36	004/AC017	Ashpan
16	008/ST073/2	Hinge Pin Set	37	004/AB044	Brick Retainer
17#	003/LD001A	Door Assembly	38	010/AB016	Side Plate
18#	003/AB012A	Door Handle	39*	010/EW51	Ash Carrier (Optional Extra)
19#	003/AB055A	Latch Receiver	40#	010/TW33	Vert Rear Flue Adaptor (Opt'l Extra)
20	008/AB110	Air Control Gasket	41#	010/LD080	Heat Shield (Optional Extra)
21	010/LD130	Air Control Plate	42	010/AC006	Ash Retainer (Optional Extra)

*These items are not shown on the drawing.
Please specify colour when ordering.

To obtain spare parts please contact your local stockist giving Model, Part No. and Description. In case of difficulty contact the manufacturer at the address shown. This drawing is for identification purposes only.



charnwood

AJ WELLS & SONS LTD

Bishops Way, Newport, Isle Of Wight PO30 5WS, United Kingdom
A Division of A.J.Wells & Sons Limited Registered In England No. 03809371



EN16510-1:2022 / EN16510-2-1:2022

ROOMHEATER

Model:	CRANMORE 3	CRANMORE 5	CRANMORE 7
EC Certificate of conformity no:	LE11-CPD-2022	LC11-CPD-2019	LD11-CPD-2020
Fuel type:	WOOD LOGS	WOOD LOGS	WOOD LOGS
Rated space heating thermal output:	3.7kW	5kW	7kW
Emission of CO in combustion products:	0.07	0.09	0.08
Mean flue gas temperature:	217	230	256
Energy efficiency:	86	84	82
Particles (mg/m ³ _n)	25	27	22
Minimum distance to combustible materials Single wall flue:			
Side:	310	350	420
Rear:	250	350	360
Insulated flue & heatshield:			
Side:	310	350	390
Rear:	100	100	110
Minimum distance to combustible materials in corner placement Insulated flue & heatshield:			
Rear corners:	130	275	180
Centre of flue:	441	563	494
Fulfilled requirements: BStV of the City of Munich and the City of Regensburg FBStVO of the City of Aachen and the City of Düsseldorf 1.and 2. level of 1. BlmSchV of Germany	✓	✓	✓

All product related data available here:

<https://www.charnwood.com/conformance-documentation>

your premier dealer

charnwood BISHOPS WAY, NEWPORT, ISLE OF WIGHT PO30 5WS, UNITED KINGDOM
TEL. +44 (0) 1983 537777 • FAX. +44 (0) 1983 537788 • WWW.CHARNWOOD.COM

A Division of A.J. Wells & Sons Limited Registered in England No. 03809371